

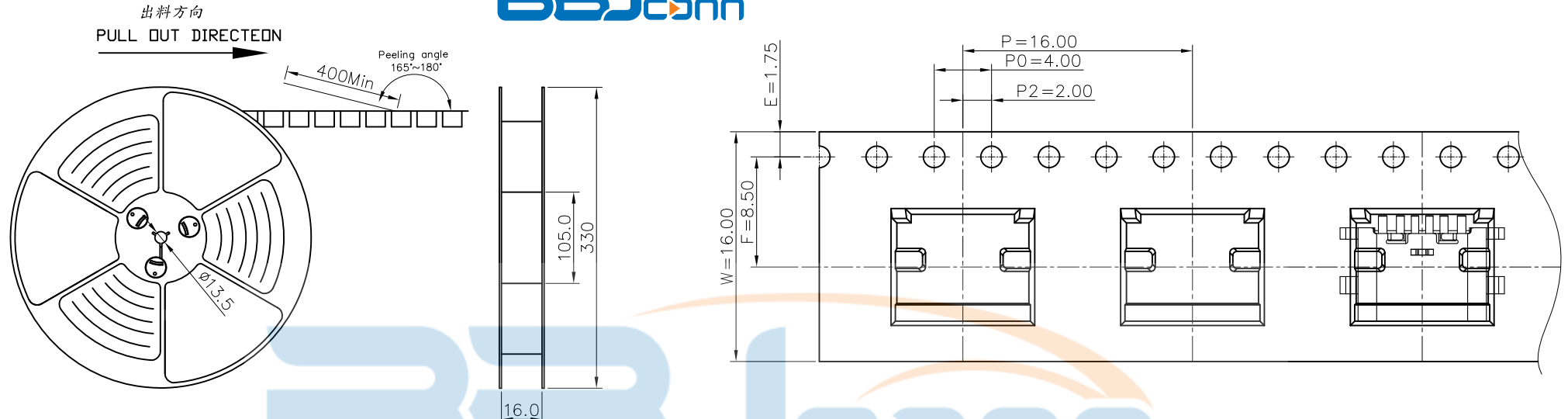



REV.	DESCRIPTION	NAME	DATE
A	NEWS ISSUE		



**NOTES**

1. 帶子引導長度  
**LEAD TAPE LENGTH**  
 出料方向  
**PULL OUT DIRECTEON**

出料方向  
**PULL OUT DIRECTEON**

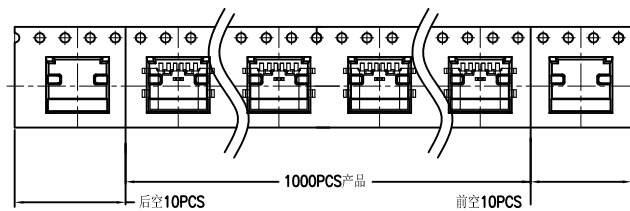

2. 上帶 剝力力為 : 0.1~1.3N(10.2gf~130gf)  
**PEELING OFF FORCE OF TOP TAPE:0.1~1.3N(10.2gf~130gf)**  
 出貨運輸過程中一定注意 :  
**THIS REQUIREMENT SHOULD BE APPLIED AT SHIPMENT :**  
 卷帶在運輸過程中不能散開  
**PEELING OFF SHOULD NOT BE ALLOWED DURING TRANSPORTATION**

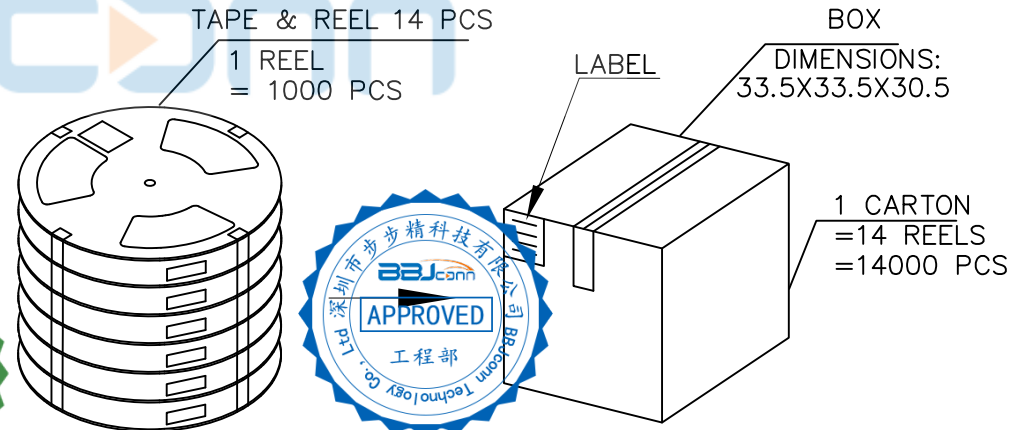

TOLERANCE UNSPECIFIED		.0 ±0.35		.00 ±0.25		.000 ±0.15		X. ° ±2.00°		CUSTOMER DRAWING	
DRAWN/ DATE		设计 LYX		SIZE:A4		UNIT:MM.		PART. NO: UC.01.33-11-0003		TITLE: TYPE-C 6P母座 L=6.8 沉板1.6 CH0.02 带中夹片	
CHECKED/ DATE		审核 HMY		SCALE: 1:1		PROJECTION		REV.: 版本			
APPROVED/ DATE		核准 LJP		DWG. PATH		0100-2		SHEET: 页码			

包裝明細表 (The detail of the packing) Carton						
產品料號 (Product No.)	包裝容量 (Packing Capacity)			重量 Weight (Kg)		
	pcs/box	boxs/Carton	Pcs/Box	N.W./Pcs	N.W./Box	G.W./Box
	1000	14	14000	----	----	----