

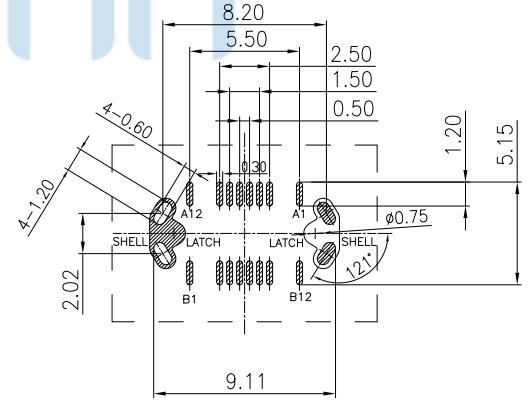

REV.	DESCRIPTION	NAME	DATE
A	NEWS ISSUE		

- NOTES:
- MATERIAL
 - HSG: HIGH TEMPERATURE THERMOPLASTIC UL94V-0; COLOR: BLACK
 - HOLDER: HIGH TEMPERATURE THERMOPLASTIC UL94V-0; COLOR: BLACK
 - CONTACT: COPPER ALLOY
 - LATCH: STAINLESS STEEL
 - SHELL: STEEL
 - OUT SHELL: STEEL
 - FINISH:
 - CONTACT:
 - 5u" [0.127um] MIN. Au PLATING ON CONTACT AREA.
 - 100u" [2.54um] MIN. TIN PLATING ON SOLDER TAIL AREA.
 - 50u" [1.27um] MIN. NICKEL. UNDERPLATING ON ALLOVER AREA.
 - LATCH:
 - 100u" [2.54um] MIN. TIN PLATING ON SOLDER TAIL AREA.
 - 50u" [1.27um] MIN. NICKEL. UNDERPLATING ON ALLOVER AREA.
 - SHELL: PEARL NICKEL
 - OUT SHELL: WELDABLE NICKEL
 - DIELECTRIC WITHSTANDING VOLTAGE: 300V AC/MINUTE FOR PER PIN.
 - INSULATION RESISTANCE: 100MΩ BETWEEN ADJACENT CONTACTS AT 300V DC.
 - TEMPERATURE RISING: 5A 30V FOR VBus AND GND PIN.
 - DATE CODE INFORMATION:

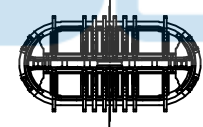
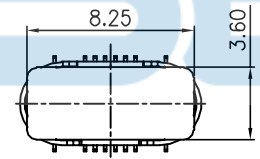
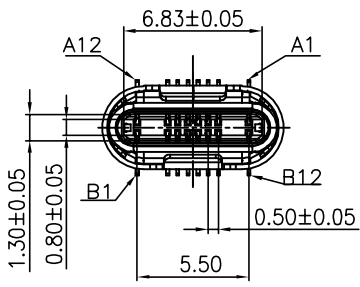
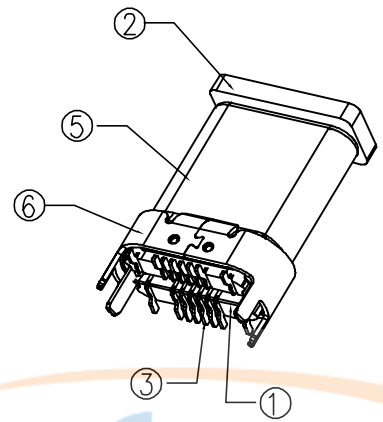
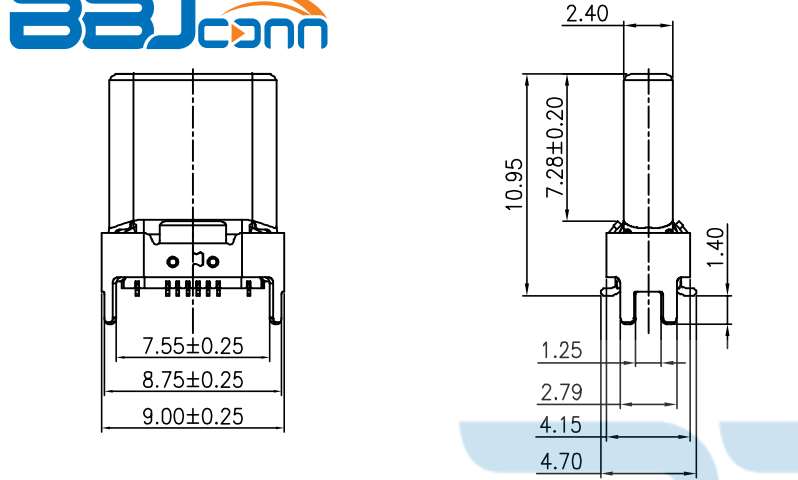

RECOMMEND P.C.B LAYOUT(COMPONENT TOP VIEW)

TOLERANCE:±0.05

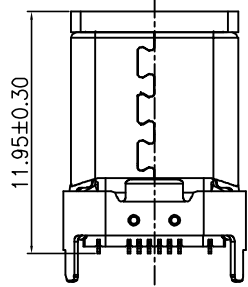
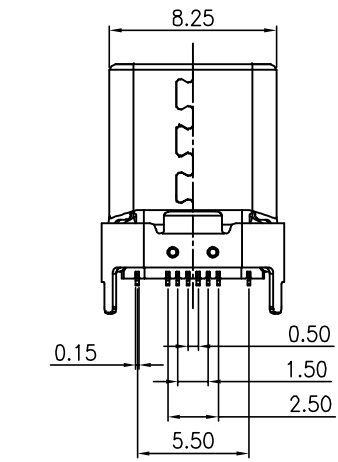

A12	A11	A10	A9	A8	A7	A6	A5	A4	A3	A2	A1
GND			VBus	SBU1	D-	D+	CC	VBus			GND
GND			VBus	Vconn			SBU2	VBus			GND
B1	B2	B3	B4	B5	B6	B7	B8	B9	B10	B11	B12

TOLERANCE UNSPECIFIED		深圳市步步精科技有限公司	
.0	±0.35	TITLE: TYPE-C 16P 公头 直立式 四脚插 H=10.95 (端子SMT) 铆合款 无小脚 SIZE:A4 UNIT:MM. PART. NO: UC.02.61-15-0001 CHECKED/ DATE 审核 LYX SCALE: 1:1 PROJECTION REV.: 版本 APPROVED/ DATE 核准 LJP DWG. PATH 0046-1 SHEET: 页码	
.00	±0.25		
.000	±0.15		
X.°	±2.00°		
CUSTOMER DRAWING			
DRAWN/ DATE	设计 HMY	SIZE:A4	UNIT:MM.
CHECKED/ DATE	审核 LYX	SCALE: 1:1	PROJECTION
APPROVED/ DATE	核准 LJP	DWG. PATH	SHEET: 页码



REV.	DESCRIPTION	NAME	DATE
A	NEWS ISSUE		

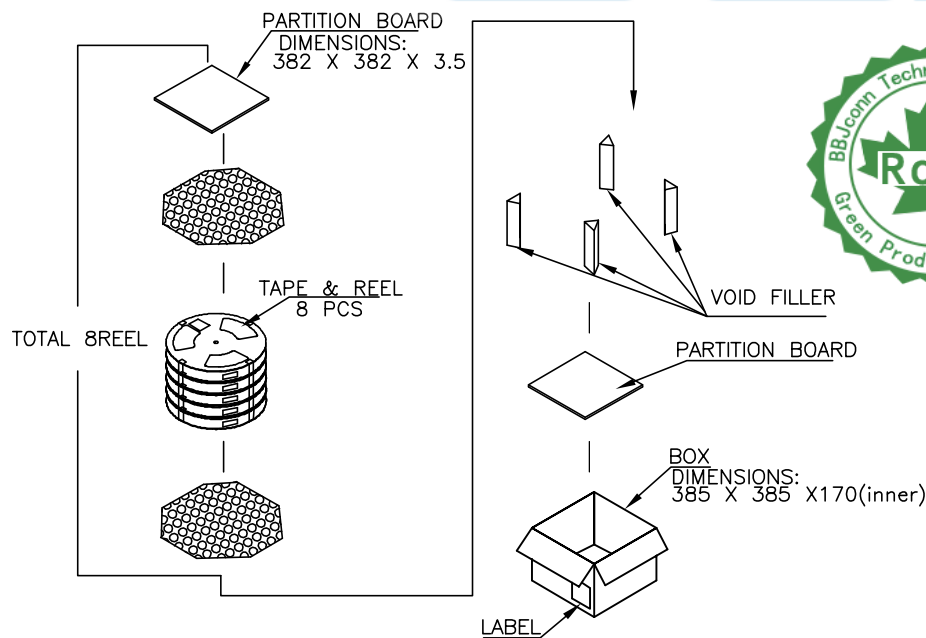
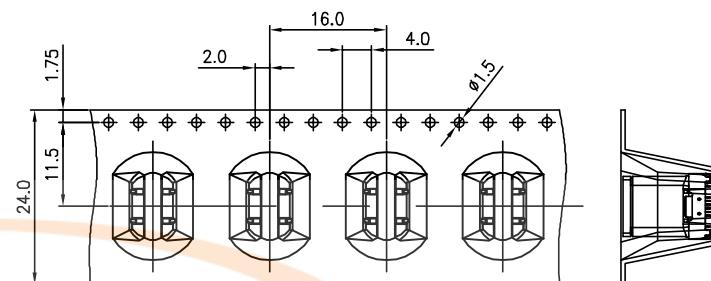
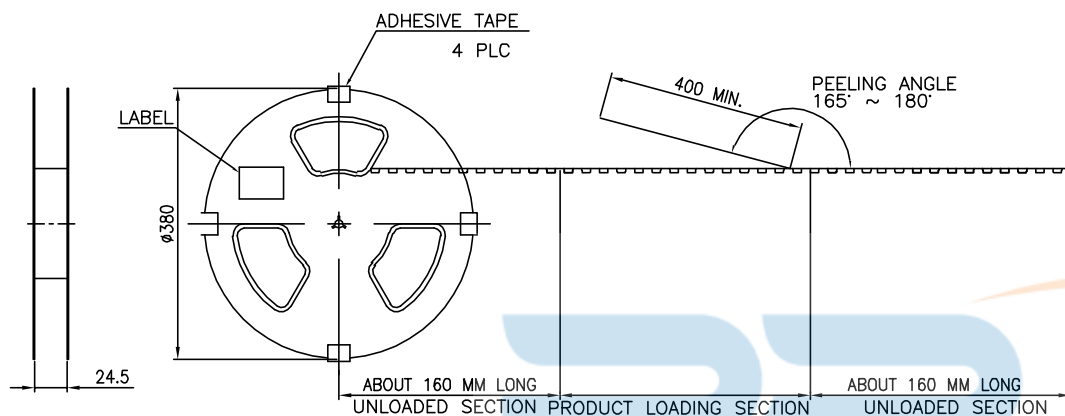

- NOTES:
- MATERIAL:
COVER TAPE: PET, COLOR: TRANSPARENT;
CARRIER TAPE: PS, COLOR: TRANSPARENT
REEL: PS, COLOR: BLUE
 - PEELING RESISTANCE: 10gf~130gf (for 12~56mm)
 - PEELING SPEED: 300mm/MINUTES



400	5	2000
PCS/REEL	REELS/BOX	PCS/BOX

TOLERANCE UNSPECIFIED		深圳市步步精科技有限公司 TITLE: TYPE-C 16P 公头 直立式 四脚插 H=10.95 (端子SMT) 铆合款 无小脚				
.0	±0.35					
.00	±0.25					
.000	±0.15					
X. °	±2.00°					
CUSTOMER DRAWING		SIZE: A4	UNIT: MM	PART. NO:	UC.02.61-15-0001	
DRAWN/ DATE	设计 HMY	CHECKED/ DATE	审核 LYX	SCALE: 1:1	PROJECTION	REV.: 版本
APPROVED/ DATE	核准 LJP	DWG. PATH	0046-1		SHEET: 页码	