

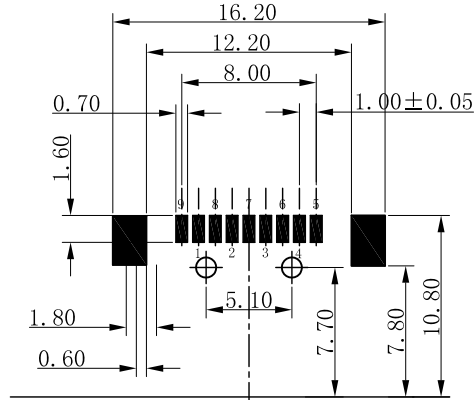

REV.	DESCRIPTION	NAME	DATE
A	NEWS ISSUE		

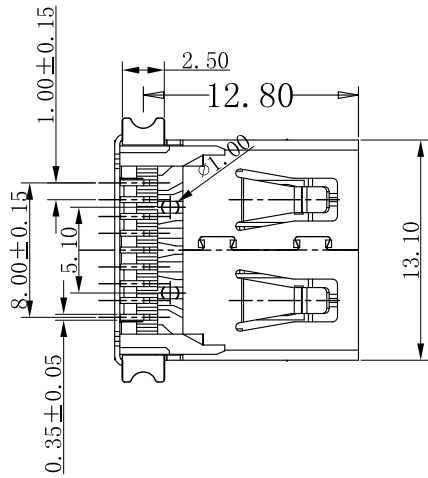

PCB EDGE
RECOMMENDED PCB LAYOUT

Pin NUMBER	SIGNAL NAME
1	VBUS
2	D-
3	D+
4	GND
5	StdA_SSRX-
6	StdA_SSRX+
7	GND_DRAIN
8	StdA_SSTX-
9	StdA_SSTX+
Shell	Shield

NOTE:

1.MATERIAL:

- 1.1 INSULATOR:LCFUL 94V-0**
- 1.2 CONTACT:BRONZE**
- 1.3 SHELL:BRASS**

2.ELECTRICAL CHARACTERISTICS;

- 2.1 CONTACT RESISTANCE:30mΩ MAXIMUM**
- 2.2 CONTACT CURRENT RATING:1.5A**
- 2.3 DIELECTRIC WITHSTANDING VOLTAGE:100 V AC R.M.S.**
- 2.4 INSULATION RESISTANCE 100 MEGOHMS MIN**
- 2.5 OPERATING TEMPERATURE:-40℃~ 85℃**

3 MECHANICAL CHARACTERISTICS:

- 3.1 MATING FORCE:3.57kgf MAX**
- 3.2 UNMATED FORCE:0.82kgf MIN AFTER TEST**
- 3.3 DURABILITY MANDATORY:1200 CYCLES**

4.PLATING

4.1 TERMINAL:

- 50u" MIN NICKEL ALL OVER**
- 80u"MIN Tin ON SOLDER AREA**
- (1~30)u" Au ON CONTACT AREA**
- 4.2 SHELL:100u"MIN.NICEL ALL OVER**

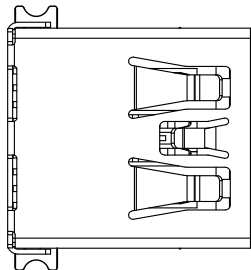
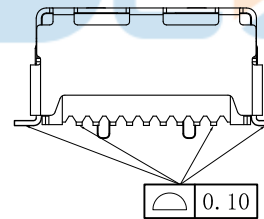
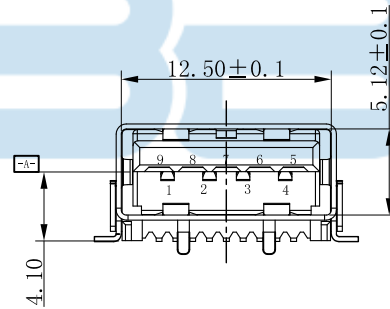
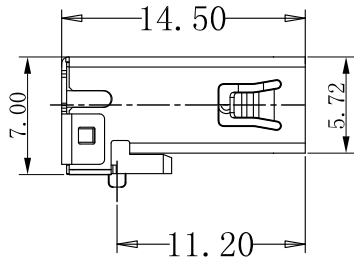

TOLERANCE UNSPECIFIED	
X.	±0.35
X.X	±0.30
X.XX	±0.25
X.XXX	±0.15
ANGEL	±1°

深圳市步步精科技有限公司

TITLE:
USB 3.0 AF 两脚全贴 带柱 L=14.50 SMT 平口 LCP蓝胶 铜壳

DRAWN/ DATE	设计 TSP	SIZE:A4	UNIT:MM.	PART. NO: UB.03.22-32-W001
CHECKED/ DATE	审核 LYX	SCALE: 1:1	PROJECTION	REV. : 版本
APPROVED/ DATE	核准 LJP	DWG. PATH	0471-1	SHEET: 页码



REV.	DESCRIPTION	NAME	DATE
A	NEWS ISSUE		

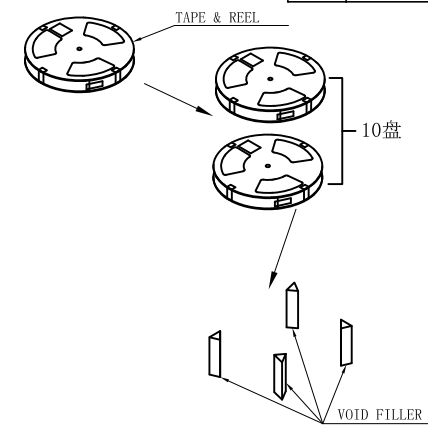
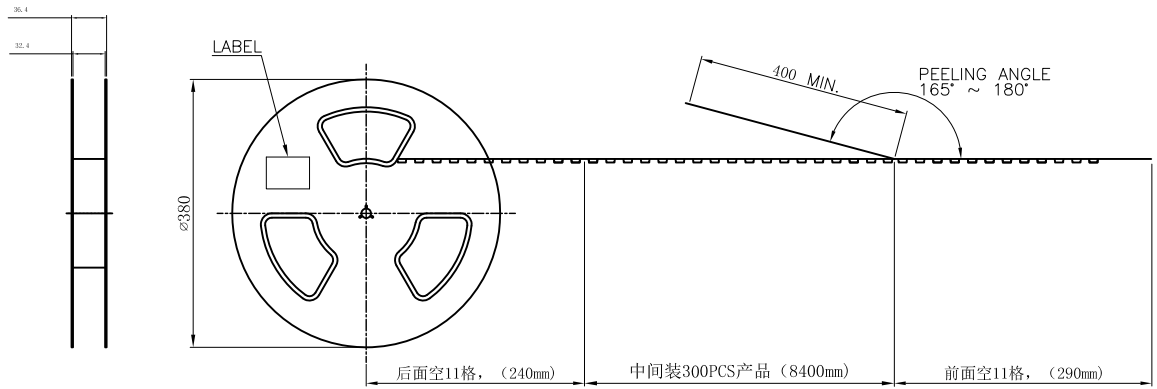

USER DIRECTION OF UNREELING →

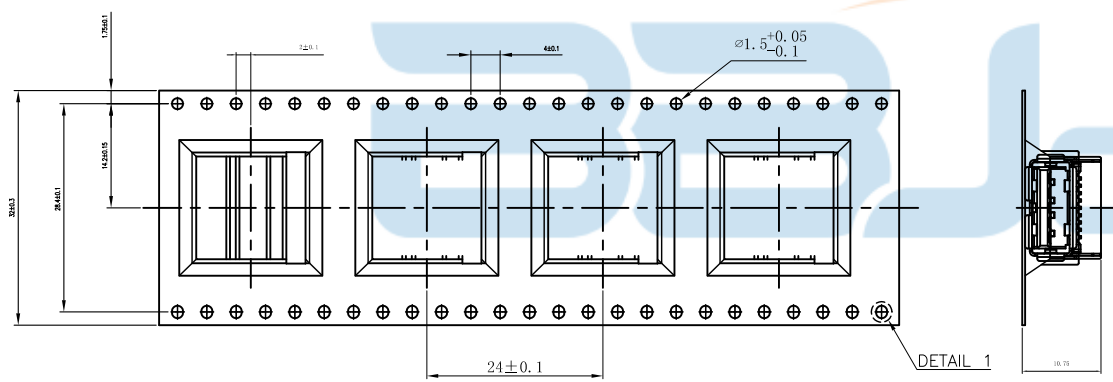

BOX DIMENSIONS: 400 X 400 X 400



300	10	3000 PCS	-- KG	-- KG
PCS/盘	盘/箱	PCS/箱	GROSS WEIGHT	NET WEIGHT

NOTE:

- MATERIAL:
 BOX: FIBREBOARD, CORRUGATED, DOUBLE WALL.
 TAPE: POLYSTYRENES, HEAT-RESISTANT TEMPERATURE: 120°C, BLACK COLOR.
 REEL: POLYSTYRENES, HEAT-RESISTANT TEMPERATURE: 70°C, BLUE COLOR.
 BAG: POLYETHYLENE, HEAT-RESISTANT TEMPERATURE: 100°C.
- PEELING STRENGTH: 0.1 ~ 1.3 N (10 ~ 130 GRAMS)
- PEELING SPEED: 300 mm/min.
- EACH BAG SHALL BE INCLUDED DESICCANT.

TOLERANCE UNSPECIFIED		深圳市步步精科技有限公司		
.0	±0.35	TITLE: USB 3.0 AF 两脚全贴 带柱 L=14.50 SMT 平口 LCP蓝胶 铜壳		
.00	±0.25			
.000	±0.15	DRAWN/ DATE: 设计 TSP SIZE:A4 UNIT:MM. PART.NO: UB.03.22-32-W001		
X.°	±2.00°	CHECKED/ DATE: 审核 LYX SCALE: 1:1 PROJECTION REV.: 版本		
CUSTOMER DRAWING		APPROVED/ DATE: 核准 LJP DWG. PATH: 0471-1 SHEET: 页码		