

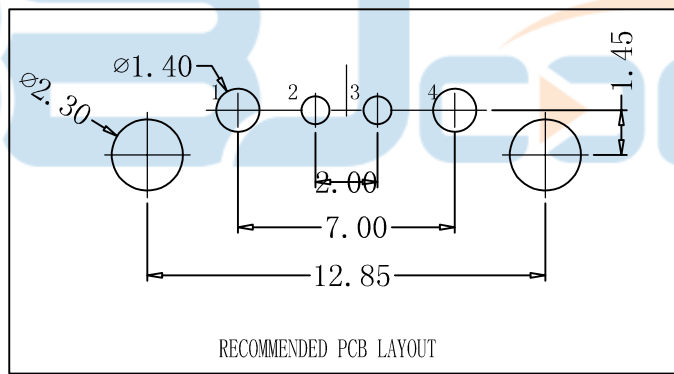

REV.	DESCRIPTION	NAME	DATE
A	NEWS ISSUE		

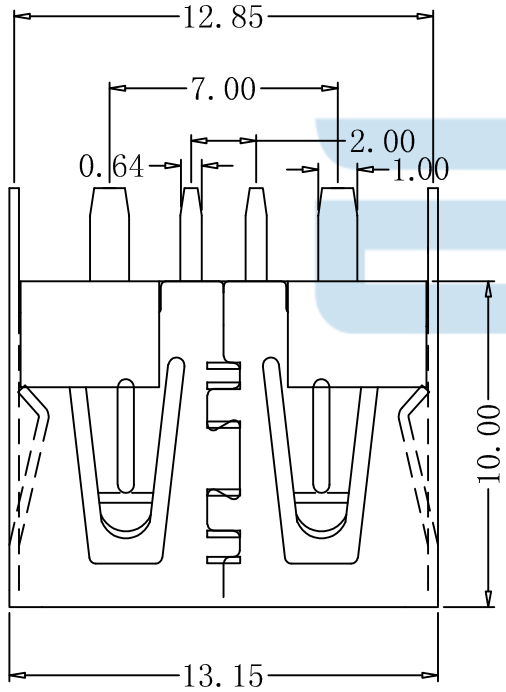
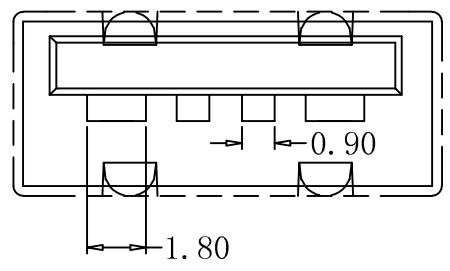
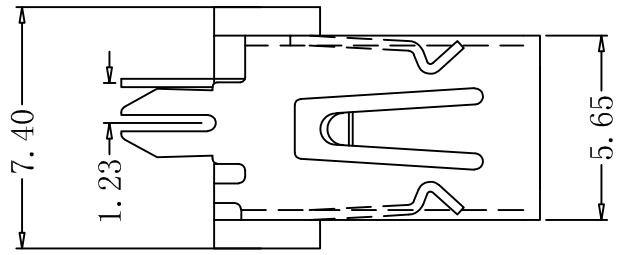

NOTE:

- ELECTRICAL CHARACTERISTICS
 - CONTACT RESISTANCE: 30 milliohms MAX.
 - INSULATION RESISTANCE: 1,000 Megohms MIN.
 - DIELECTRIC WITHSTANDING VOLTAGE: 500V AC MIN
 - OPERATION TEMPERATURE: -20°C TO +85°C
 - MECHANICAL CHARACTERISTICS
 - RETENTION FORCE: MIN. 100gf/PIN
 - DURABILITY: 6,000 CYCLES
 - INSERTION FORCE: 3.57Kg MAXIMUM AT A MAXIMUM RATE OF 12.5mm
EXTRACTION FORCE: 1.02Kg MIN AT A MAXIMUM RATE OF 12.5mm
 - MATERIAL:
 - HOUSING: PA9T UL 94-V0. COLOR: orange / black
 - CONTACT: Phosphor copper 7025 terminal T=0.25±0.02mm
(SURFACE PLATING: Gold 1U"+Sn60-100U"+Ni40U")
 - SHEEL: SPCC
- RoHS Compliant



GENERAL TOLERANCES		深圳市步步精科技有限公司			
.X:	±0.20	TITLE: USB 2.0 180度直脚直插 平口铁壳PA9T黑胶 大电流(5A) 短体H=10.0			
.XX:	±0.10	DRAWN/ DATE:	设计 TSP	SIZE: A4	UNIT: MM.
.XXX:	±0.05	CHECKED/ DATE:	审核 LYX	PART. NO:	UB.01.12-11-V010
NGEL:	± 3.0°	APPROVED/ DATE:	核准 LJP	SCALE: 1:1	PROJECTION
			DWG. PATH	0383-1	REV.: 版本
					SHEET: 页码

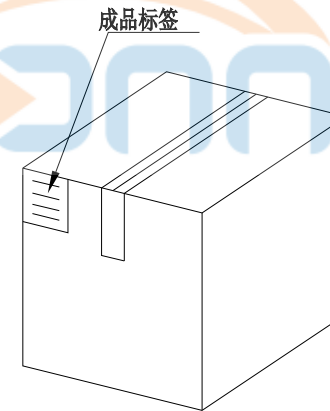
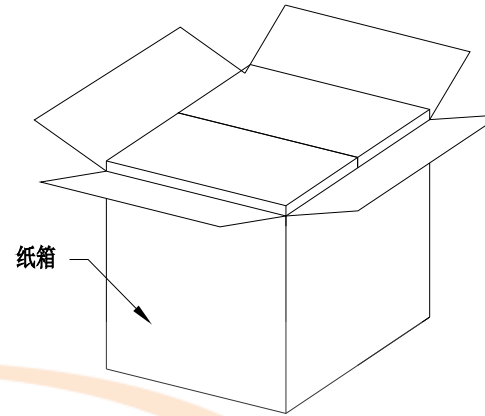
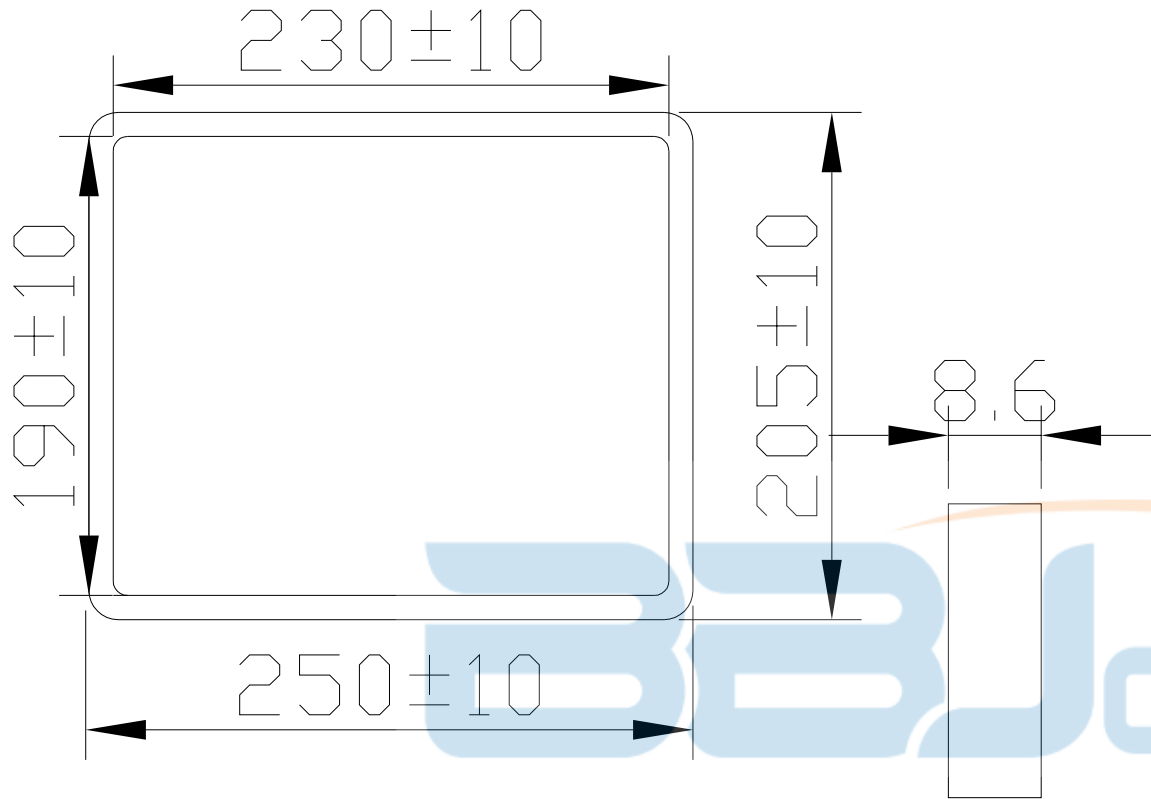

纸箱规格：350*210*290

1. 包装要求:

- 1.1 每盒吸塑盒包装100 pcs;
- 1.2 每20盘放一箱，共计2000PCS;
- 1.3 纸箱外贴上标签



TOLERANCE UNSPECIFIED		深圳市步步精科技有限公司 TITLE: USB 2.0 180度直脚直插 平口铁壳PA9T黑胶 大电流 (5A) 短体H=10.0								
.0	±0.35									
.00	±0.25	DRAWN/ DATE		设计	TSP	SIZE: A4	UNIT: MM.	PART. NO: UB.01.12-11-V010		
.000	±0.15	CHECKED/ DATE		审核	LYX	SCALE: 1:1		PROJECTION	REV.: 版本	
X.°	±2.00°	APPROVED/ DATE		核准	LJP	DWG. PATH	0383-1		SHEET: 页码	
CUSTOMER DRAWING										