

规格说明: Specifications:

电气特性: Electrical:

1. 额定电流: Current Rating  
1.0A/contact terminal
2. 额定电压: Voltage Rating  
30V DC
3. 接触阻抗: Contact Resistance  
50 milliohms MAX
4. 耐电压: Dielectric Withstanding Voltage:  
300 V AC For one minuter
5. 绝缘阻抗: Insulation Resistance:  
100MEGA ohms MIN

原材料: Raw material:

1. 塑胶: Plastic cement:  
Hing Temperature Thermoplastics,  
LCP Black/Nature
2. 端子: Contact: Copper Alloy C5191/C2680
3. 外壳: Shell: Copper Alloy C2680

电镀: Electroplate:

1. 端子: Contact: Plated Gold in Mating Area;  
Tin On Solder Talls
2. 外壳: Shell:  
Nickel Plating

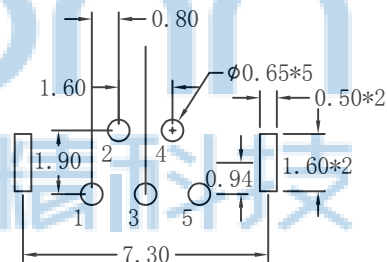
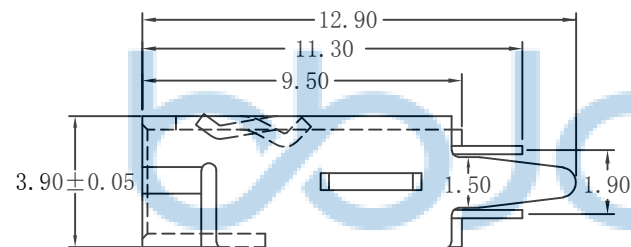

RECOMMENDED PCB LAYOUT



Since 1987

步步精科技

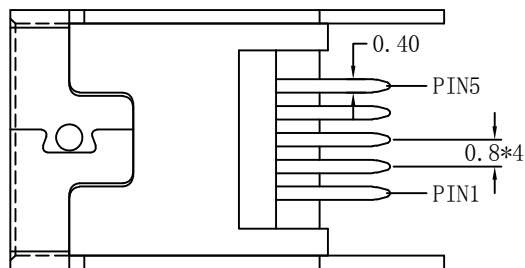

Pin Numbe	Signal Name
1	VBUS
2	D-
3	D+
4	ID
5	GND

THIS DOCUMENT IS THE SOLE PROPERTY OF BBJconn Technology Co.,Ltd. Corporation AND SHOULD NOT BE USED IN WHOLE OR IN PART WITHOUT PRIOR WRITTEN PERMISSION.		<b>深圳市步步精科技有限公司</b> .X: ±0.38 .X': ±3" .XX: ±0.25 .X': ±2" .XXX: ±0.13 .XX': ±1"	
APPD.	JM_Zheng	23/05'02	NAME: MINI USB 5P 母座 180度 H=9.50 直脚 铜壳
CHKD.	LYX	23/05'02	PJ. NO.: UB.07.12-12-9003
DR.	SGF	23/05'02	SIZE: A4   DRW NO.:
PDWG.NO: 0064-2			FINISH: SEE NOTES   MAT'L.: SEE NOTES
			SCALE: N/A   REV.: A3   UNIT: mm   PAGE: 1/1

REV.	ECN NO	CONTENT	DATE	ENGINEER
A0			2023 20/04	

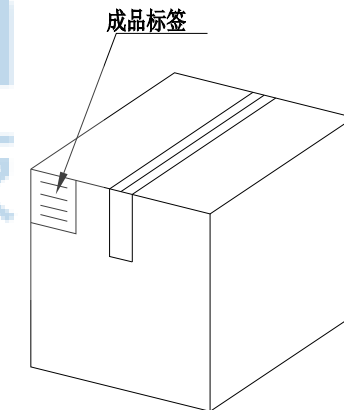
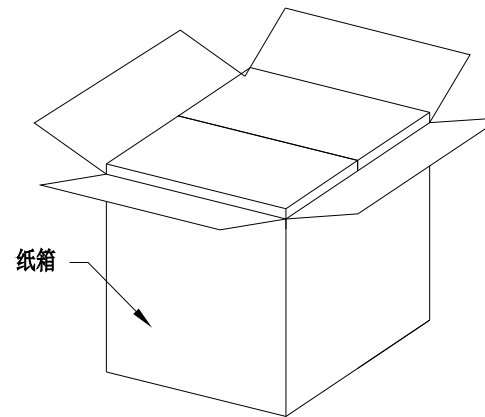
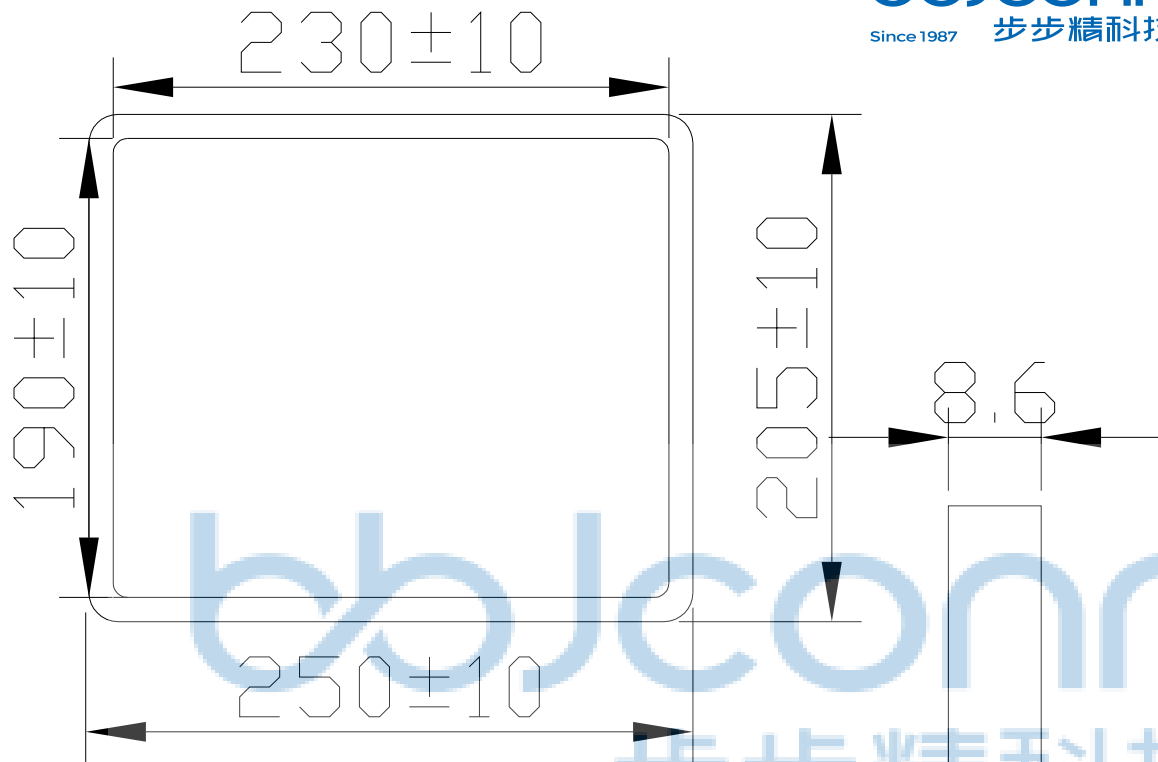

纸箱规格：350\*210\*290

1. 包装要求:

- 1.1 每盒吸塑盒包装100pcs;
- 1.2 每20盘放一箱，共计2000PCS;
- 1.3 纸箱外贴上标签



THIS DOCUMENT IS THE SOLE PROPERTY OF BBJconn Technology Co.,Ltd. Corporation AND SHOULD NOT BE USED IN WHOLE OR IN PART WITHOUT PRIOR WRITTEN PERMISSION.		<b>深圳市步步精科技有限公司</b>	
.X: ±0.38 .XX: ±0.25 .XXX: ±0.13		X*: ±3" .X*: ±2" .XX*: ±1"	
APPD.	JM_Zheng	23/05'02	NAME: MINI USB 5P 母座 180度 H=9.50 直脚 铜壳
CHKD.	LYX	23/05'02	PJ. NO.: UB.07.12-12-9003
DR.	SGF	23/05'02	SIZE: A4   DRW NO.:
PDWG.NO: 0064-2		FINISH: SEE NOTES   MAT'L.: SEE NOTES	
		SCALE: N/A   REV.: A3   UNIT: mm   PAGE: 1/1	