

REV.	ECN NO	CONTENT	DATE	ENGINEER
A0			2023 20/04	

- CONTACT CURRENT RATING: 1A.
- CONTACT RESISTANCE: 100 mΩ MAX.;
- INSULATION RESISTANCE: 100MΩ MIN.;
- DIELECTRIC WITHSTANDING: 500V AC MIN.;
- DURABILITY: 5,000 CYCLES MIN.;
- CONNECTOR MATING FORCES: 30N MAX.;
- CONNECTOR UNMATING FORCES: 3N MIN.;
- TERPROOF LEVEL: IP67;

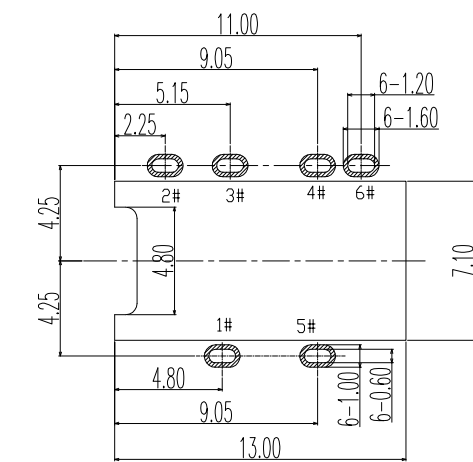

P.C.B LAYOUT
TOP VIEW

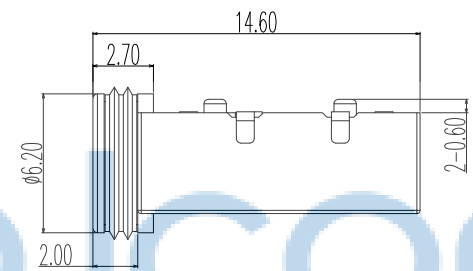
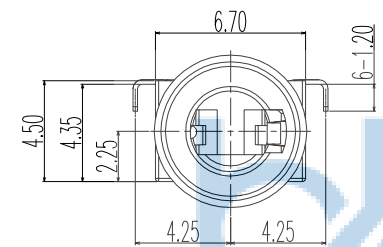
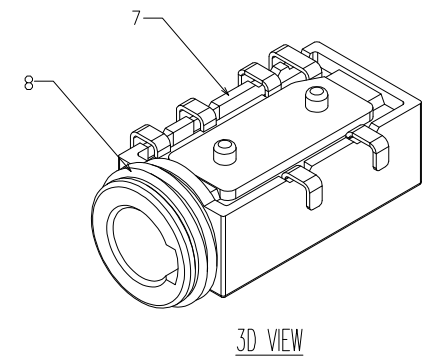
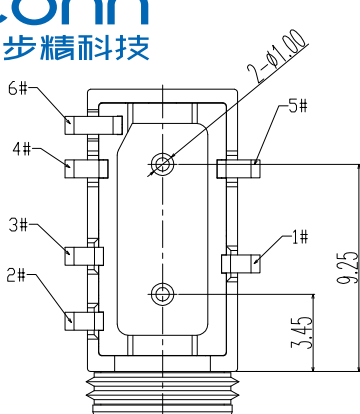
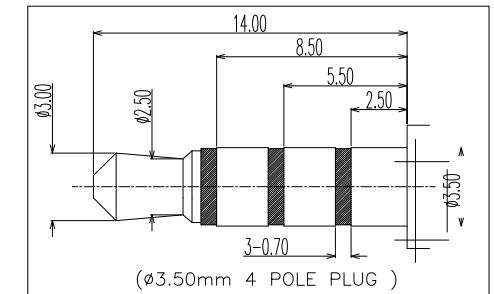
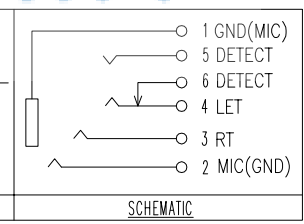
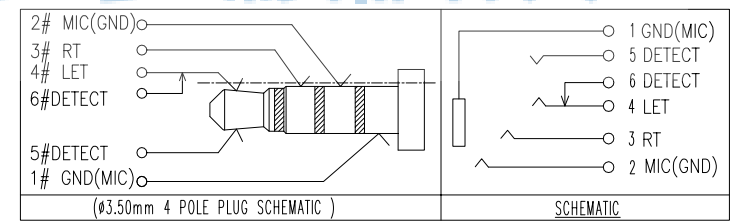
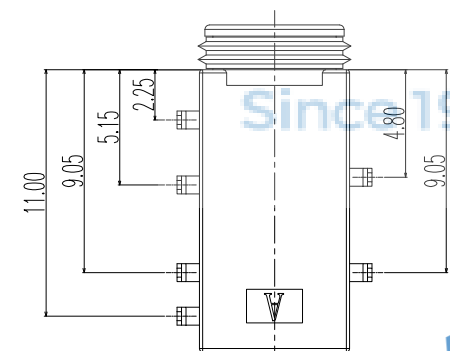

ITEM	NAME	QTY	DESCRIPTION	NOTE
8	WATERPROOF RING	1	SILICA GEL	
7	HOUSING	1	HIGH TEMPERATURE PLASTIC MATERIALE; COLOR BLACK	
6	TERMINAL 6#	1	COPPER ALLOY; NICKEL UNDER PLATING OVERALL;GOLD FLASH PLATING ON SOLDER AREA ;GOLD FLASH PLATING ON CONTACT AREA	T=0.20mm
5	TERMINAL 5#	1	COPPER ALLOY; NICKEL UNDER PLATING OVERALL;GOLD FLASH PLATING ON SOLDER AREA ;GOLD FLASH PLATING ON CONTACT AREA	T=0.20mm
4	TERMINAL 4#	1	COPPER ALLOY; NICKEL UNDER PLATING OVERALL;GOLD FLASH PLATING ON SOLDER AREA ;GOLD FLASH PLATING ON CONTACT AREA	T=0.20mm
3	TERMINAL 3#	1	COPPER ALLOY; NICKEL UNDER PLATING OVERALL;GOLD FLASH PLATING ON SOLDER AREA ;GOLD FLASH PLATING ON CONTACT AREA	T=0.20mm
2	TERMINAL 2#	1	COPPER ALLOY; NICKEL UNDER PLATING OVERALL;GOLD FLASH PLATING ON SOLDER AREA ;GOLD FLASH PLATING ON CONTACT AREA	T=0.20mm
1	TERMINAL 1#	1	STAINLESS STEEL; NICKEL UNDER PLATING OVERALL;GOLD FLASH PLATING ON SOLDER AREA ;GOLD FLASH PLATING ON CONTACT AREA	T=0.20mm

THIS DOCUMENT IS THE SOLE PROPERTY OF BBJconn Technology Co.,Ltd. Corporation AND SHOULD NOT BE USED IN WHOLE OR IN PART WITHOUT PRIOR WRITTEN PERMISSION.

PDWG.NO: 0076-1

DR. SGF 23/05/02

深圳市步步精科技有限公司

NAME: 3.5耳机座 有头 带柱六脚插 沉板4.35 四节 防水IP67 (PJ35A080-F0G1BR-A)

APPD. JM_Zheng 23/05/02

CHKD. LYX 23/05/02

PJ. NO.: PJ.03.22-01-3030

SIZE: A4 DRW NO.:

FINISH: SEE NOTES MAT'L.: SEE NOTES

SCALE: N/A REV.: A0 UNIT: mm PAGE: 1/1

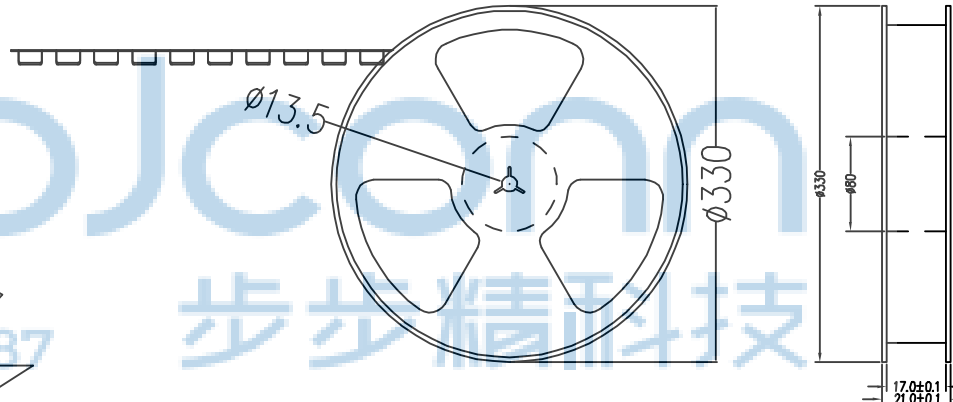
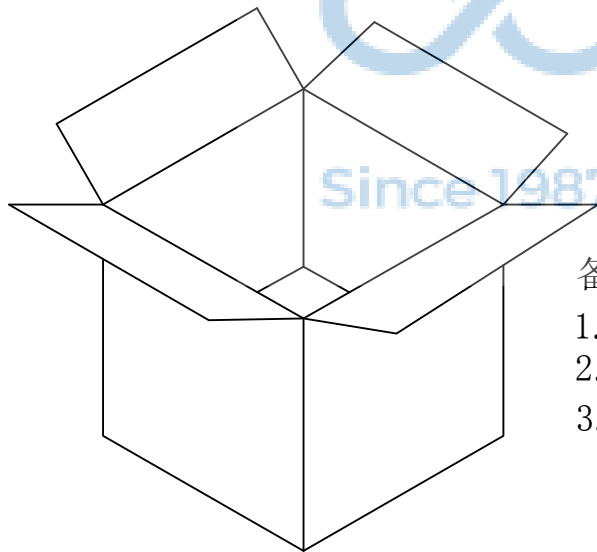
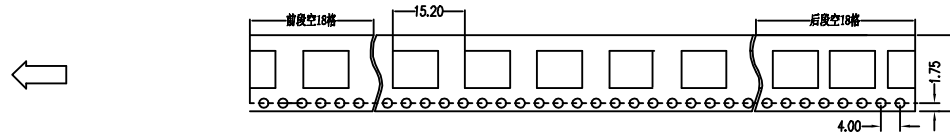
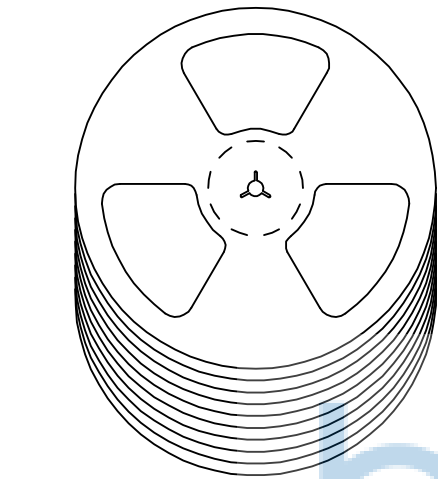

备注:

1. 包装数量: 1000/PCS/卷, 10卷/箱或15卷/箱。
2. 包装袋长度: 每卷前后各空10-20个空格, 中间包装。
3. 材质:
载体: 聚丙烯 (PS), 阻抗 $10^{6-9} \Omega$
上带: 聚乙烯 (PET), 阻抗 $10^{6-11} \Omega$
卷盘: 聚苯乙烯。

纸箱规格: 345*345*23MM

纸箱规格: 345*345*35MM

THIS DOCUMENT IS THE SOLE PROPERTY OF BBJconn Technology Co.,Ltd. Corporation AND SHOULD NOT BE USED IN WHOLE OR IN PART WITHOUT PRIOR WRITTEN PERMISSION.		深圳市步步精科技有限公司 .X: ± 0.38 .X': $\pm 3^*$.XX: ± 0.25 .X'': $\pm 2^*$.XXX: ± 0.13 .XX': $\pm 1^*$		NAME: 3.5耳机座 有头 带柱六脚插 沉板4.35 四节 防水IP67 (PJ35A080-F06J1BR-A)				
APPD.	JM_Zheng	23/05'02	PJ. NO.: PJ.03.22-01-3030		SIZE: A4	DRW NO.:		
CHKD.	LYX	23/05'02	FINISH: SEE NOTES		MAT'L.: SEE NOTES			
PDWG.NO:	0076-1	DR.	SGF	23/05'02	SCALE: N/A	REV.: A0	UNIT: mm	PAGE: 1/1