

REV.	ECN NO.	CONTENT	DATE	ENGINEER
AO			2023 20/04	

- CONTACT CURRENT RATING: 1A.
- CONTACT RESISTANCE: 100 mΩ MAX.;
- INSULATION RESISTANCE: 100MΩ MIN.;
- DIELECTRIC WITHSTANDING: 500V AC MIN.;
- DURABILITY: 5,000 CYCLES MIN.;
- CONNECTOR MATING FORCES: 29.4N MAX.;
- CONNECTOR UNMATING FORCES: 2.94N MIN.;

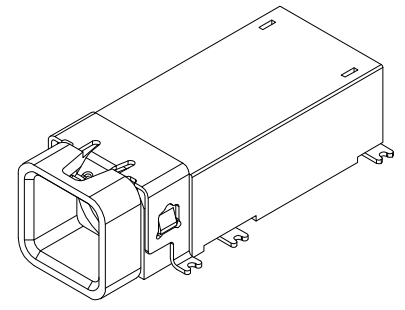

3D VIEW

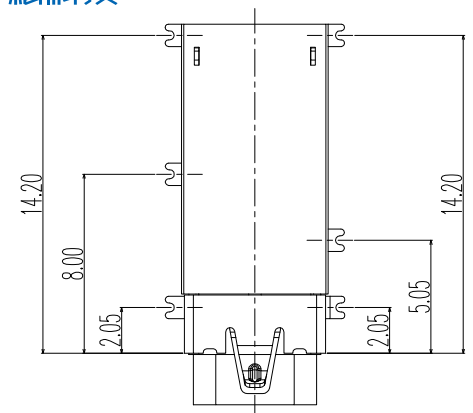
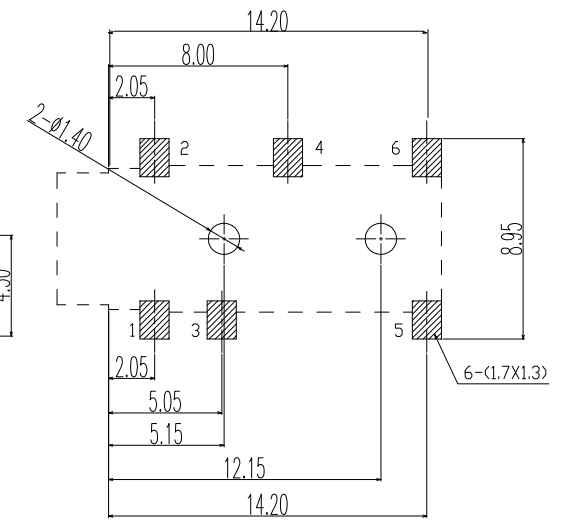
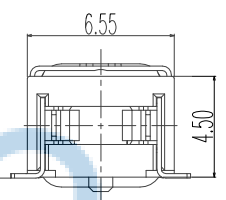
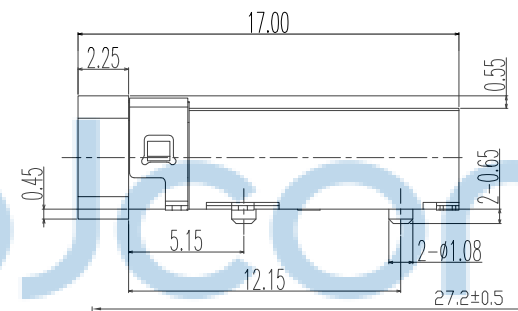
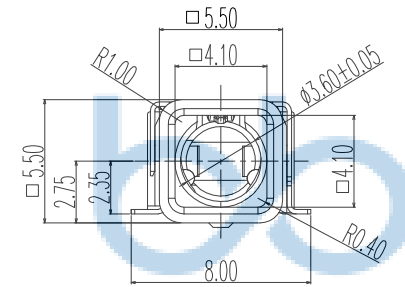

P.C.B LAYOUT
TOP VIEW

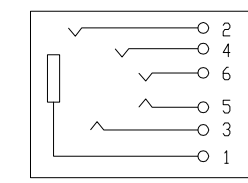

SCHEMATIC

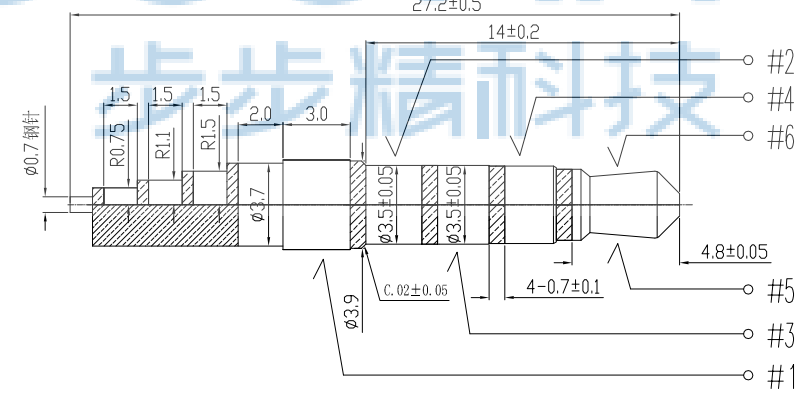
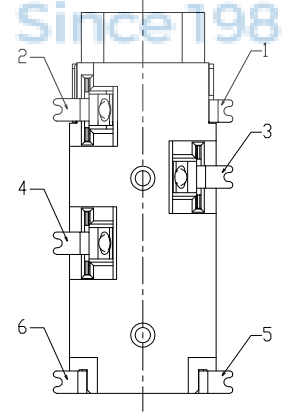

(ø3.50mm 5 POLE PLUG DETAIL DRAWING)



ITEM	NAME	Q'TY	DESCRIPTION	NOTE
5	HOUSING	1	HIGHT TEMPERATURE PLASTIC COLOR BLACK	
4	TERMINAL 4#	1	PHOSPHOR BRONZE; NICKEL UNDER PLATING OVERALL;GOLD FLASH PLATING ON SOLDER AREA ;GOLD FLASH PLATING ON CONTACT AREA	T=0.20mm
3	TERMINAL 3#	1	PHOSPHOR BRONZE; NICKEL UNDER PLATING OVERALL;GOLD FLASH PLATING ON SOLDER AREA ;GOLD FLASH PLATING ON CONTACT AREA	T=0.20mm
2	TERMINAL 2#	3	PHOSPHOR BRONZE; NICKEL UNDER PLATING OVERALL;GOLD FLASH PLATING ON SOLDER AREA ;GOLD FLASH PLATING ON CONTACT AREA	T=0.20mm
1	TERMINAL 1#	1	PHOSPHOR BRONZE; NICKEL UNDER PLATING OVERALL;GOLD FLASH PLATING OVERALL;	T=0.20mm

THIS DOCUMENT IS THE SOLE PROPERTY OF BBJconn Technology Co.,Ltd. Corporation AND SHOULD NOT BE USED IN WHOLE OR IN PART WITHOUT PRIOR WRITTEN PERMISSION.

深圳市步步精科技有限公司

NAME: 3.5耳机座 六脚贴 带柱 五节 (PJ35A079-F06J1BR-A)

PJ. NO.: PJ.01.22-01-3018

SIZE: A4 | DRW NO.:

FINISH: SEE NOTES | MAT'L.: SEE NOTES

SCALE: N/A | REV.: A0 | UNIT: mm | PAGE: 1/1

APPD. JM_Zheng 23/05'02

CHKD. LYX 23/05'02

DR. SGF 23/05'02

PDWG.NO: 0076-1

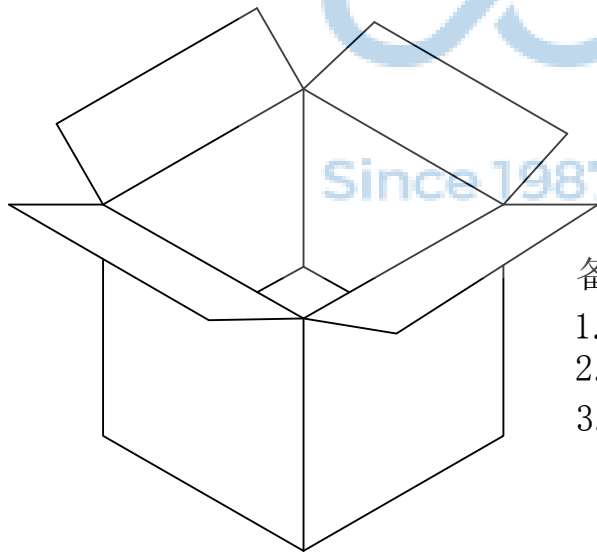
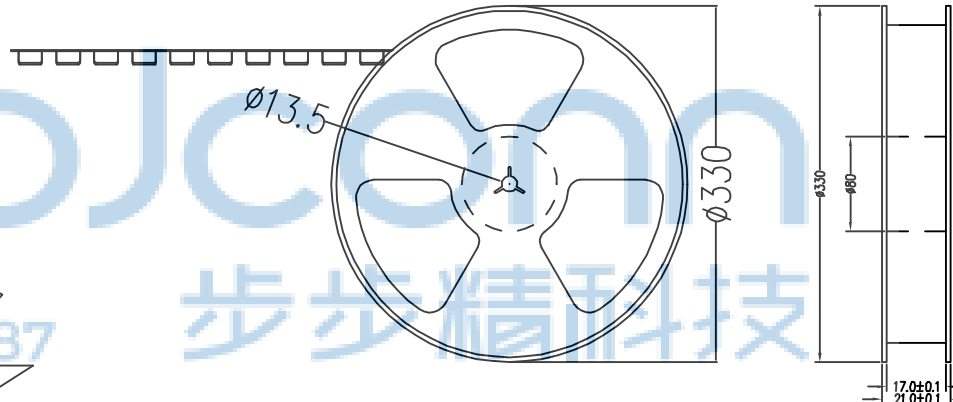
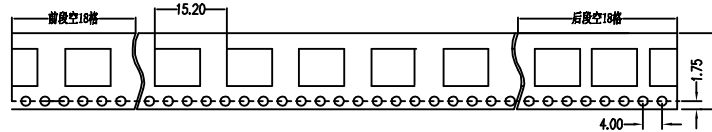
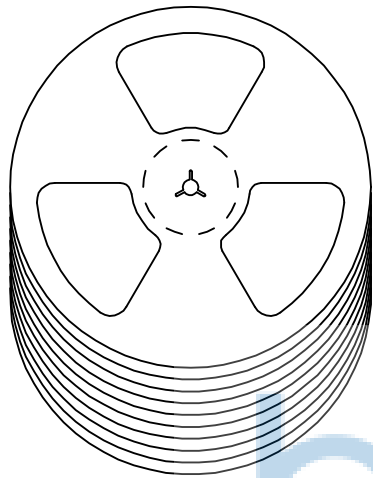

备注:

1. 包装数量: 1000/PCS/卷, 10卷/箱或15卷/箱。
2. 包装袋长度: 每卷前后各空10-20个空格, 中间包装。
3. 材质:
 载体: 聚丙烯 (PS), 阻抗 $10^{6-9} \Omega$
 上带: 聚乙烯 (PET), 阻抗 $10^{6-11} \Omega$
 卷盘: 聚苯乙烯。

纸箱规格: 345*345*23MM

纸箱规格: 345*345*35MM

THIS DOCUMENT IS THE SOLE PROPERTY OF BBJconn Technology Co.,Ltd. Corporation AND SHOULD NOT BE USED IN WHOLE OR IN PART WITHOUT PRIOR WRITTEN PERMISSION.		深圳市步步精科技有限公司	
.X: ±0.38 .XX: ±0.25 .XXX: ±0.13		X': ±3" X'': ±2" X'': ±1"	
APPD.	JM_Zheng	23/05'02	NAME: 3.5耳机座 六脚贴 带柱 五节 (PJ35A079-F06J1BR-A)
CHKD.	LYX	23/05'02	PJ. NO.: PJ.01.22-01-3018
DR.	SGF	23/05'02	SIZE: A4 DRW NO.:
PDWG.NO: 0076-1		FINISH: SEE NOTES MAT'L.: SEE NOTES	
		SCALE: N/A REV.: A0 UNIT: mm PAGE: 1/1	