

REV.	ECN NO.	CONTENT	DATE	ENGINEER
A0			2023 20/04	

- NOTES:
- CONTACT CURRENT RATING: 1A.
  - CONTACT RESISTANCE: 50 mΩ MAX.;
  - INSULATION RESISTANCE: 100MΩ MIN.;
  - DIELECTRIC WITHSTANDING: 500V AC MIN.;
  - DURABILITY: 2,000 CYCLES MIN.;
  - CONNECTOR MATING FORCES: 29.4N (3.00Kgf) MAX.;
  - CONNECTOR UNMATING FORCES: 2.94N(0.30Kgf) MIN.;

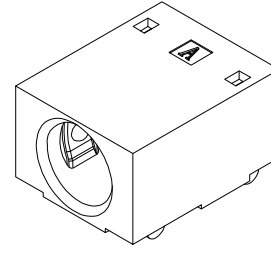

3D VIEW

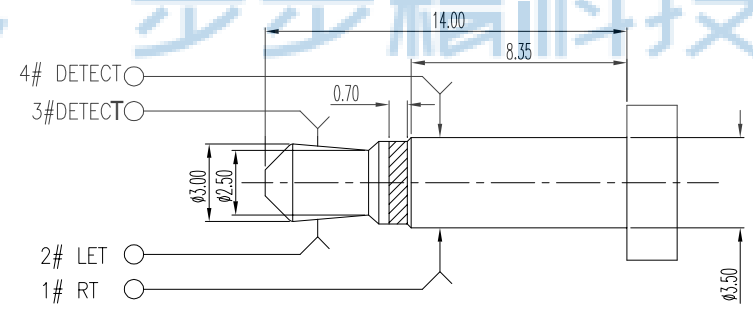
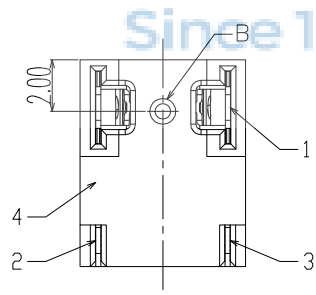
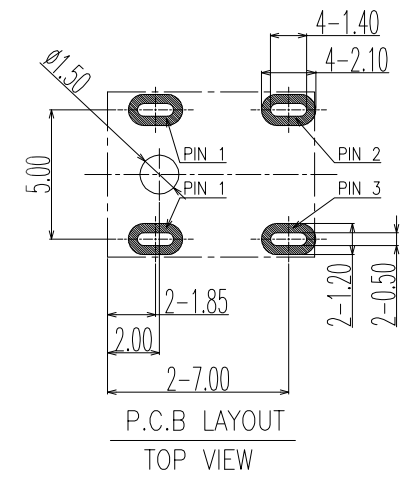
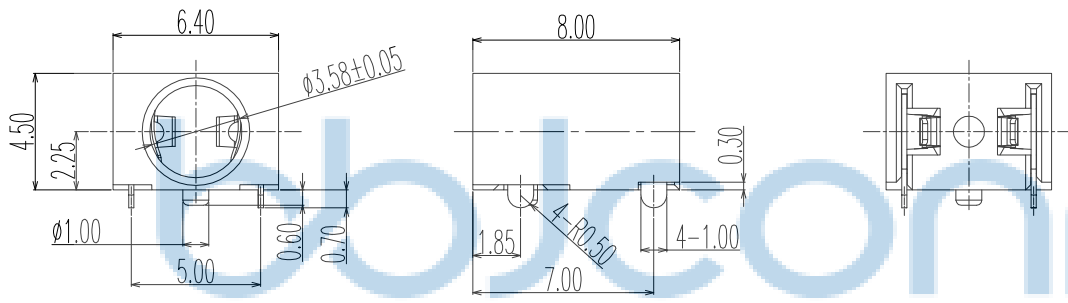

( $\phi 3.50$ mm 4 POLE PLUG DETAIL DRAWING)

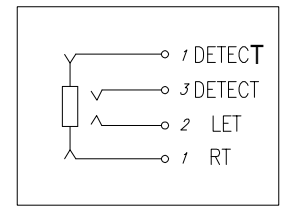

SCHEMATIC



ITEM	NAME	Q'TY	DESCRIPTION	NOTE
4	HOUSING	1	HIGHT TEMPERATURE PLASTIC COLOR BLACK	
3	TERMINAL 3#	1	PHOSPHOR BRONZE; NICKEL (40u"MIN.) UNDER PLATING OVERALL;GOLD FLASH PLATING ON SOLDER AREA ;GOLD FLASH PLATING ON CONTACT AREA	T=0.20mm
2	TERMINAL 2#	1		T=0.20mm
1	TERMINAL 1#	1		T=0.20mm

THIS DOCUMENT IS THE SOLE PROPERTY OF BBJconn Technology Co.,Ltd.  
Corporation AND SHOULD NOT BE USED IN WHOLE OR IN PART WITHOUT PRIOR WRITTEN PERMISSION.

PDWG.NO: 0076-1

DR. SGF 23/05/02

APPD. JM\_Zheng 23/05/02

CHKD. LYX 23/05/02

NAME: 3.5耳机座 四脚插 带柱 两节 (PJ35A061-F04J1BR-A)

PJ. NO.: PJ.02.21-01-3005

SIZE: A4 | DRW NO.:

FINISH: SEE NOTES | MAT'L.: SEE NOTES

SCALE: N/A | REV.: A0 | UNIT: mm | PAGE: 1/1

**深圳市步步精科技有限公司**

REV.	ECN NO.	CONTENT	DATE	ENGINEER
A0			2023 20/04	

PE袋规格: 260\*185

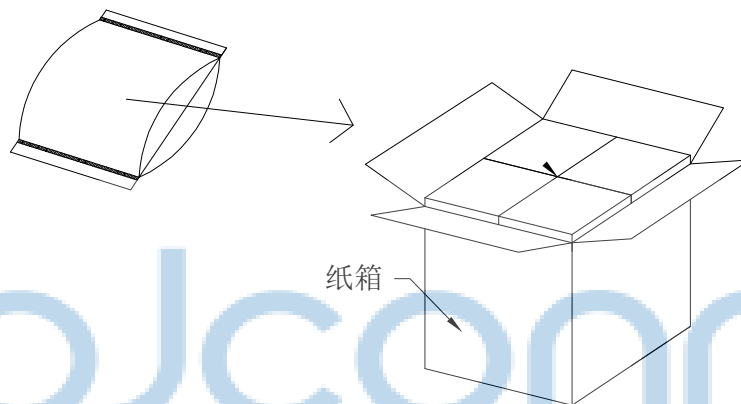

成品标签

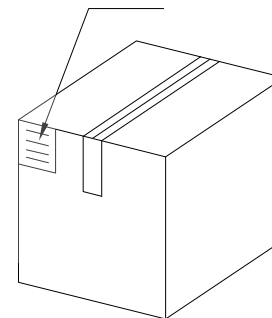

1. 包装要求:
- 1.1 每个PE袋包装1000pcs;
  - 1.2 每1袋放一小纸盒;
  - 1.3 每20个小纸盒放一个纸箱, 共计20000pcs;
  - 1.4 纸箱外贴上标签

THIS DOCUMENT IS THE SOLE PROPERTY OF BBJconn Technology Co.,Ltd. Corporation AND SHOULD NOT BE USED IN WHOLE OR IN PART WITHOUT PRIOR WRITTEN PERMISSION.		深圳市步步精科技有限公司 .X: ±0.38    .X': ±3" .XX: ±0.25    .X'': ±2" .XXX: ±0.13    .XX': ±1"		NAME: 3.5耳机座 四脚插 带柱 两节 (PJ35A061-F04J1BR-A)	
APPD.	JM_Zheng	23/05'02	PJ. NO.: PJ.02.21-01-3005		
CHKD.	LYX	23/05'02	SIZE: A4   DRW NO.:		
PDWG.NO:	0076-1	DR.	SGF	23/05'02	FINISH: SEE NOTES   MAT'L.: SEE NOTES SCALE: N/A   REV.: A0   UNIT: mm   PAGE: 1/1