

REV.	ECN NO.	CONTENT	DATE	ENGINEER
AO			2023 20/04	

NOTES:

- CONTACT CURRENT RATING: 1A.
- CONTACT RESISTANCE: 50 mΩ MAX.;
- INSULATION RESISTANCE: 100MΩ MIN.;
- DIELECTRIC WITHSTANDING: 500V AC MIN.;
- DURABILITY: 5,000 CYCLES MIN.;
- CONNECTOR MATING FORCES: 30N MAX.;
- CONNECTOR UNMATING FORCES: 3N MIN.;

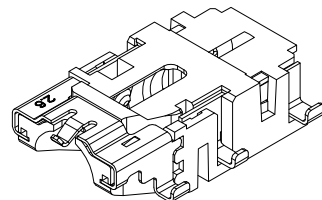
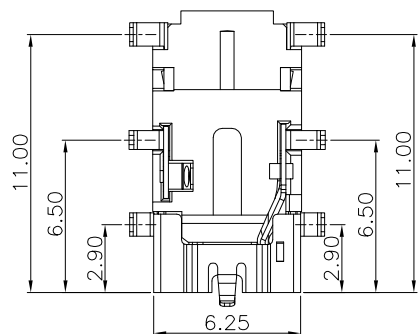

3D VIEW

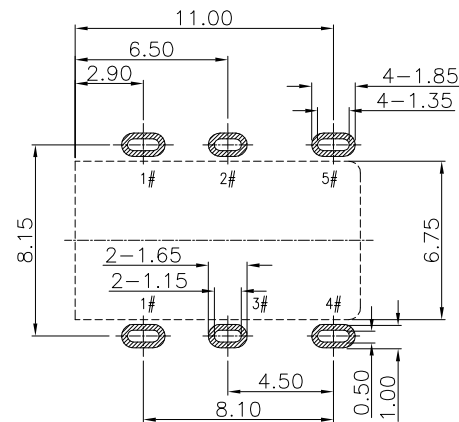
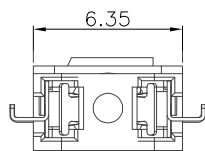
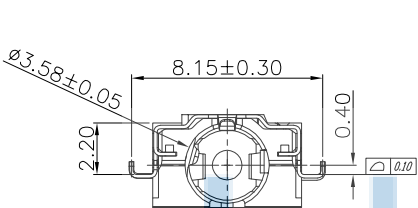

P.C.B LAYOUT
TOP VIEW

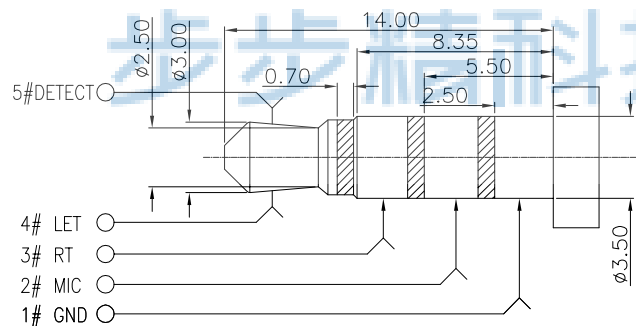
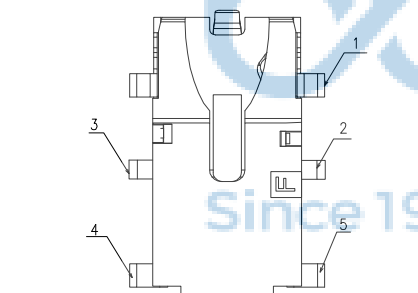

(Ø3.50mm 4 POLE PLUG DETAIL DRAWING)

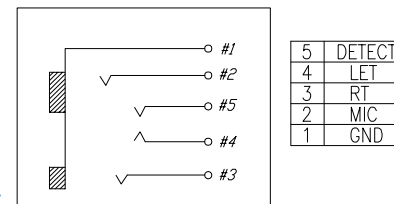

SCHEMATIC

5	DETECT
4	LET
3	RT
2	MIC
1	GND



ITEM	PART NAME	Q'TY	MATERIAL	REMARK
⑥	HOUSING	1	HIGHT TEMPERATURE PLASTIC COLOR BLACK	
⑤	CONTACT 5#	1	STAINLESS STEEL; NICKEL UNDER PLATING OVERALL,GOLD FLASH PLATING ON SOLDER AREA ;GOLD FLASH PLATING ON CONTACT AREA	T=0.15
④	CONTACT 4#	1	STAINLESS STEEL; NICKEL UNDER PLATING OVERALL,GOLD FLASH PLATING ON SOLDER AREA ;GOLD FLASH PLATING ON CONTACT AREA	T=0.15
③	CONTACT 3#	1	PHORPHOS BRONZE; NICKEL UNDER PLATING OVERALL,GOLD FLASH PLATING ON SOLDER AREA ;GOLD FLASH PLATING ON CONTACT AREA	T=0.2
②	CONTACT 2#	1	PHORPHOS BRONZE; NICKEL UNDER PLATING OVERALL,GOLD FLASH PLATING ON SOLDER AREA ;GOLD FLASH PLATING ON CONTACT AREA	T=0.2
①	CONTACT 1#	1	STAINLESS STEEL; NICKEL UNDER PLATING OVERALL,GOLD FLASH ON OVERALL	T=0.15

THIS DOCUMENT IS THE
SOLE PROPERTY OF
BBJconn Technology Co.,Ltd.
Corporation AND SHOULD
NOT BE USED IN WHOLE
OR IN PART WITHOUT
PRIOR WRITTEN PERMISSION.

深圳市步步精科技有限公司

NAME:	3.5耳机座 上斜口 沉板2.2 六脚插 四节 (PJ35A020-F05G1BR-A)
PJ. NO.:	PJ.03.22-01-3007
SIZE:	A4
DRW NO.:	
FINISH:	SEE NOTES
MAT'L.:	SEE NOTES
SCALE:	N/A
REV.:	A0
UNIT:	mm
PAGE:	1/1

PDWG.NO: 0076-1

DR. SGF 23/05'02

REV.	ECN NO.	CONTENT	DATE	ENGINEER
AO			2023 20/04	

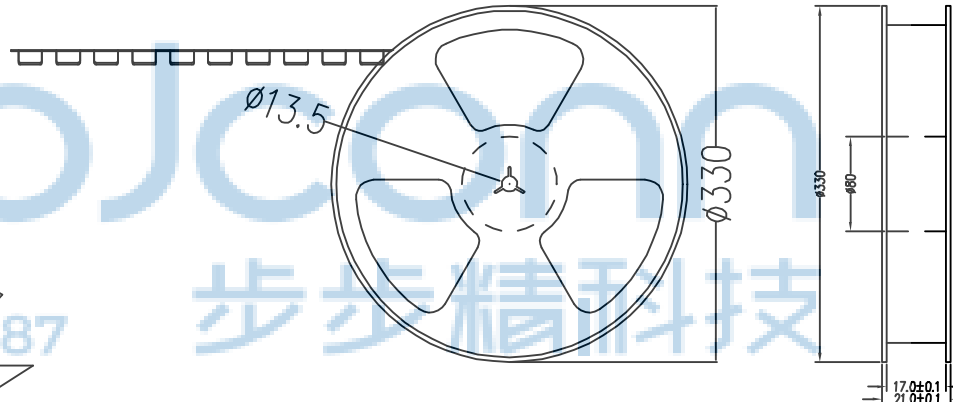
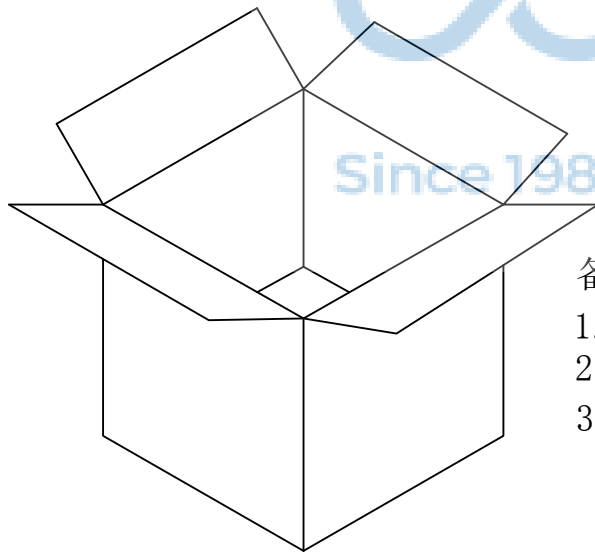
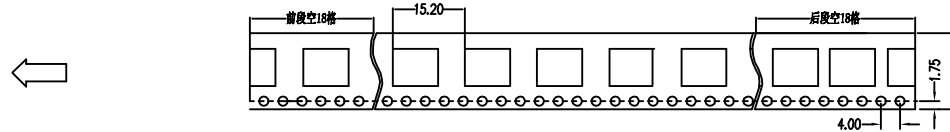
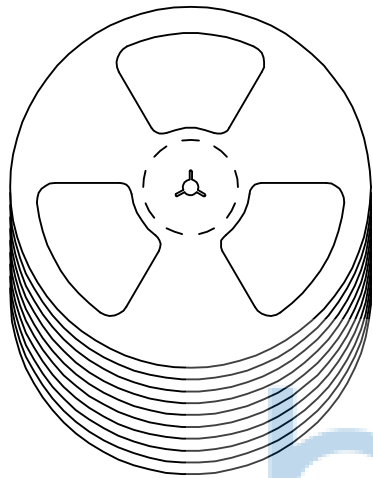

备注:

1. 包装数量: 1000/PCS/卷, 10卷/箱或15卷/箱。
2. 包装袋长度: 每卷前后各空10-20个空格, 中间包装。
3. 材质:
载体: 聚丙烯 (PS), 阻抗 $10^{6-9} \Omega$
上带: 聚乙烯 (PET), 阻抗 $10^{6-11} \Omega$
卷盘: 聚苯乙烯。

纸箱规格: 345*345*23MM

纸箱规格: 345*345*35MM

THIS DOCUMENT IS THE SOLE PROPERTY OF BBJconn Technology Co.,Ltd. Corporation AND SHOULD NOT BE USED IN WHOLE OR IN PART WITHOUT PRIOR WRITTEN PERMISSION.		PDWG.NO: 0076-1		深圳市步步精科技有限公司 .X: ±0.38 .X': ±3" .XX: ±0.25 .X": ±2" .XXX: ±0.13 .XX': ±1"		NAME: 3.5耳机座 上斜口 沉板2.2 六脚插 四节 (PJ35A020-F05G1BR-A)		
APPD.	JM_Zheng	23/05'02	PJ. NO.: PJ.03.22-01-3007		SIZE: A4 DRW NO.:		FINISH: SEE NOTES MAT'L.: SEE NOTES	
CHKD.	LYX	23/05'02	SCALE: N/A REV.: A0 UNIT: mm PAGE: 1/1					
DR.	SGF	23/05'02						