

REV.	ECN NO.	CONTENT	DATE	ENGINEER
A0			2023 20/04	

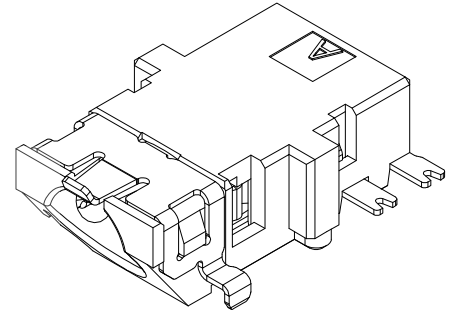

3D VIEW

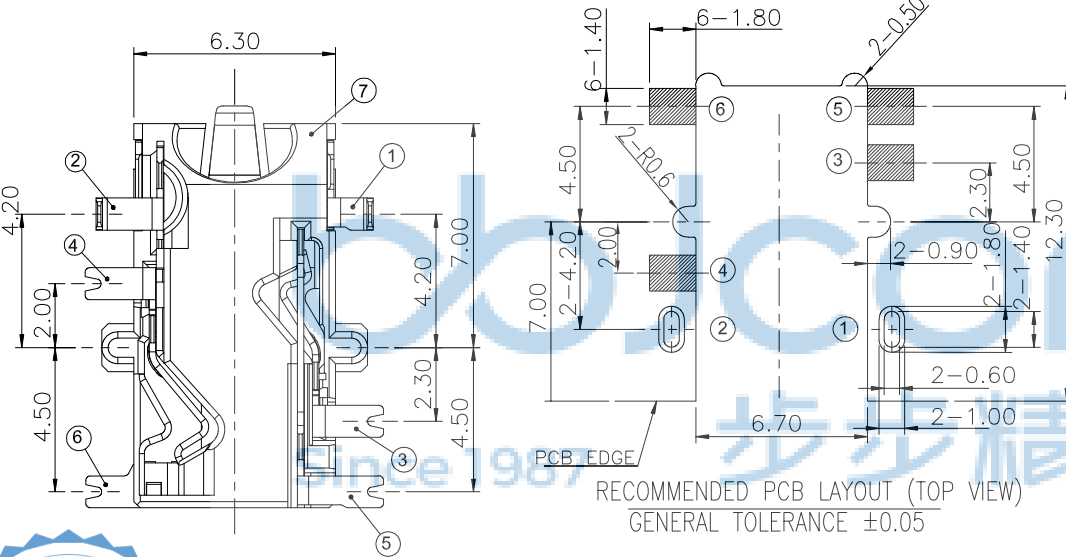
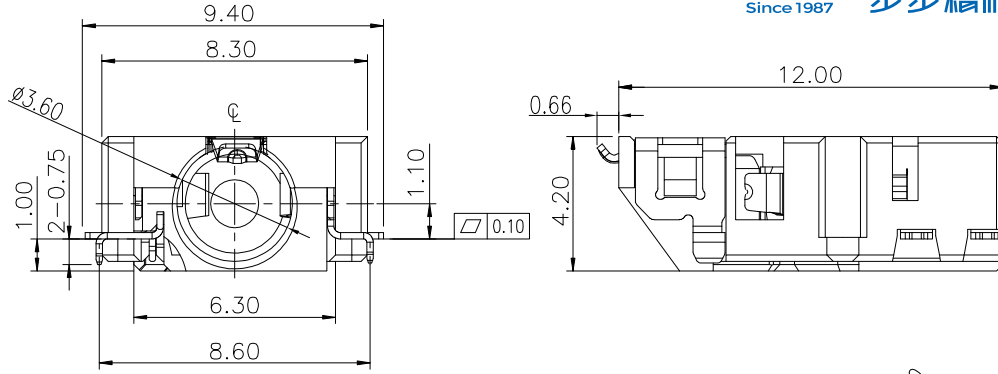
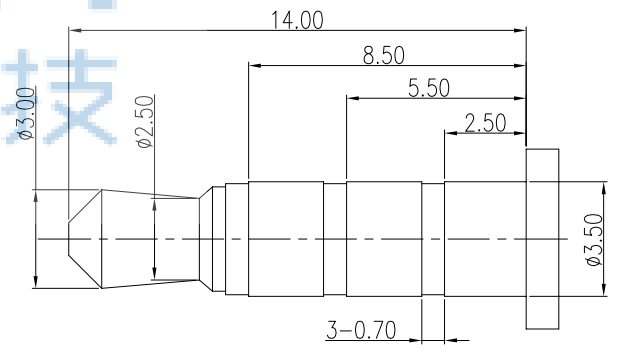

(φ3.50mm 4 POLE PLUG DETAIL DRAWING)

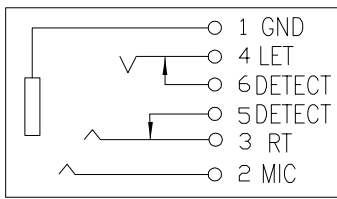
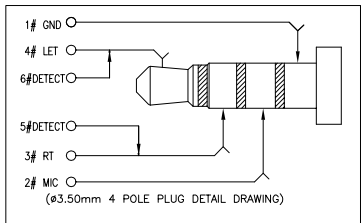

SCHEMATIC



ITEM	NAME	Q'TY	DESCRIPTION	NOTE
7	HOUSING	1	HIGHT TEMPERATURE PLASTIC COLOR BLACK	
6	TERMINAL 6#	1	PHOSPHOR BRONZE; NICKEL UNDER PLATING OVERALL;GOLD FLASH ON SOLDER AREA	T=0.20
5	TERMINAL 5#	1	PHOSPHOR BRONZE; NICKEL UNDER PLATING OVERALL;GOLD FLASH ON SOLDER AREA	T=0.20
4	TERMINAL 4#	1	PHOSPHOR BRONZE; NICKEL UNDER PLATING OVERALL;GOLD FLASH ON SOLDER AREA ;GOLD FLASH ON CONTACT AREA	T=0.20
3	TERMINAL 3#	1	PHOSPHOR BRONZE; NICKEL UNDER PLATING OVERALL;GOLD FLASH ON SOLDER AREA ;GOLD FLASH ON CONTACT AREA	T=0.20
2	TERMINAL 2#	1	PHOSPHOR BRONZE; NICKEL UNDER PLATING OVERALL;GOLD FLASH ON SOLDER AREA ;GOLD FLASH ON CONTACT AREA	T=0.20
1	TERMINAL 1#	1	PHOSPHOR BRONZE; NICKEL UNDER PLATING OVERALL;GOLD FLASH ON SOLDER AREA ;GOLD FLASH ON CONTACT AREA	T=0.20

THIS DOCUMENT IS THE SOLE PROPERTY OF BBJconn Technology Co.,Ltd. Corporation AND SHOULD NOT BE USED IN WHOLE OR IN PART WITHOUT PRIOR WRITTEN PERMISSION.

PDWG.NO: 0076-1

DR. SGF 23/05'02

深圳市步步精科技有限公司

NAME: 3.5耳机座 无头 沉板1.0 斜口 两脚插四脚贴 四节 (PJ35A083-F06J1BR-D)

APPD. JM\_Zheng 23/05'02

CHKD. LYX 23/05'02

PJ. NO.: PJ.03.22-01-3011

SIZE: A4 DRW NO.:

FINISH: SEE NOTES MAT'L.: SEE NOTES

SCALE: N/A REV.: A0 UNIT: mm PAGE: 1/1

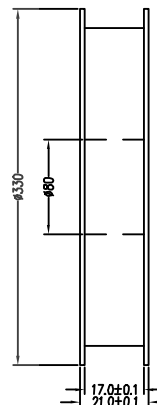
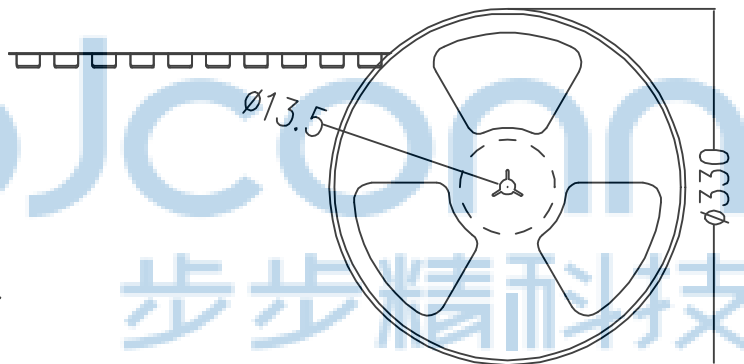
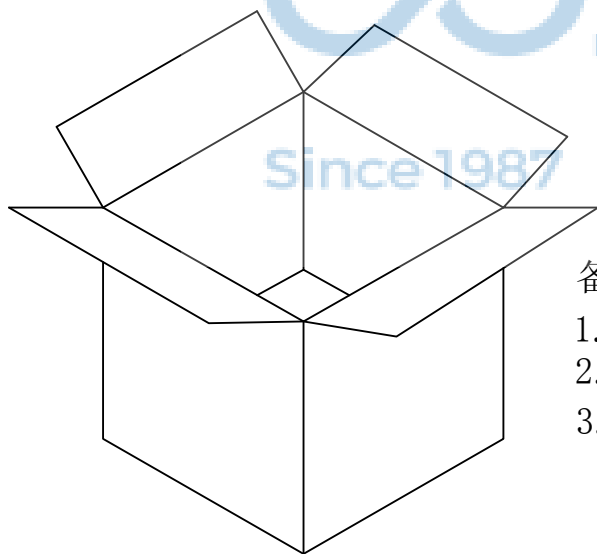
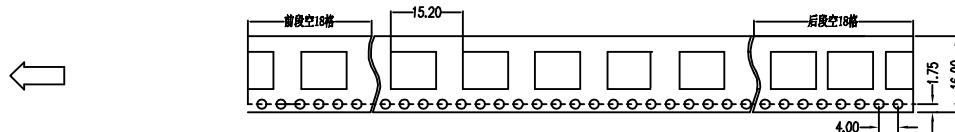
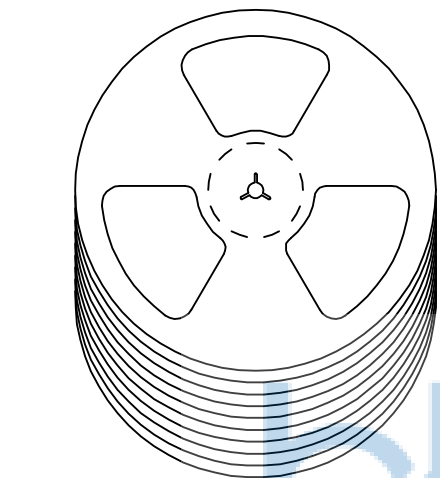

备注:

1. 包装数量: 1000/PCS/卷, 10卷/箱或15卷/箱。
2. 包装袋长度: 每卷前后各空10-20个空格, 中间包装。
3. 材质:  
载体: 聚丙烯 (PS), 阻抗 $10^{6-9} \Omega$   
上带: 聚乙烯 (PET), 阻抗 $10^{6-11} \Omega$   
卷盘: 聚苯乙烯。

纸箱规格: 345\*345\*23MM

纸箱规格: 345\*345\*35MM

THIS DOCUMENT IS THE SOLE PROPERTY OF BBJconn Technology Co.,Ltd. Corporation AND SHOULD NOT BE USED IN WHOLE OR IN PART WITHOUT PRIOR WRITTEN PERMISSION.		深圳市步步精科技有限公司 .X: ±0.38 .X': ±3" .XX: ±0.25 .X": ±2" .XXX: ±0.13 .XX': ±1"		NAME: 3.5耳机座 无头 沉板1.0 斜口 两脚插四脚贴 四节 (PJ35A083-F06J1BR-D)	
APPD.	JM_Zheng	23/05'02	PJ. NO.: PJ.03.22-01-3011 SIZE: A4 DRW NO.:		FINISH: SEE NOTES
CHKD.	LYX	23/05'02	SCALE: N/A		REV.: A0
PDWG.NO:	0076-1	DR.	SGF	23/05'02	UNIT: mm
				PAGE: 1/1	