

REV.	ECN NO	CONTENT	DATE	ENGINEER
A0				

- 技术要求:
- 1、塑件材料: LCP (UL-94V-0)
  - 2、接触件: 黄铜镀锡
  - 3、接触电阻:  $\leq 20m\Omega$
  - 4、绝缘电阻:  $\geq 100M\Omega$
  - 5、额定电压: 125V AC DC
  - 6、额定电流: 1.0A AC DC
  - 7、耐压: 能承受500V AC/Min ute
  - 8、工作温度:  $-25^{\circ} \sim +85^{\circ}$
  - 9、可焊性试验: 浸锡面积 $\geq 95\%$ 温度 $260^{+5}_{-0}$ ia, 时间 $2.5 \pm 0.5$ 秒
  - 10、铅和镉等六大有害物质含量要符合环保要求

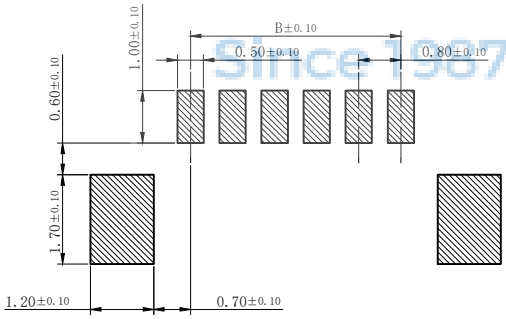
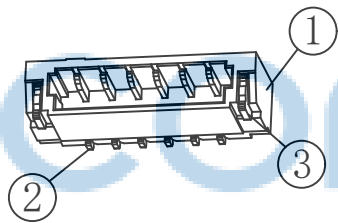
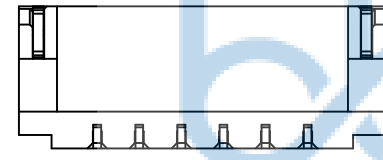
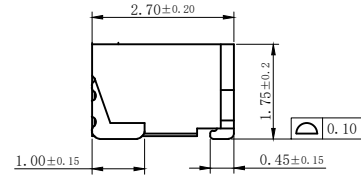
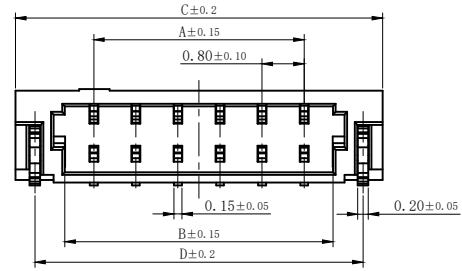

SUGGESTED PCB LAYOUT  
(COMPONENT SIDE)

CKT	Dim A	Dim B	Dim C	Dim D
2	0.80	1.90	3.78	3.04
3	1.60	2.70	4.58	3.84
4	2.40	3.50	5.38	4.64
5	3.20	4.30	6.18	5.44
6	4.00	5.10	6.98	6.24
7	4.80	5.90	7.78	7.04
8	5.60	6.70	8.58	7.84
9	6.40	7.50	9.38	8.64
10	7.20	8.30	10.18	9.44
11	8.00	9.10	10.98	10.24
12	8.80	9.90	11.78	11.04
13	9.60	10.70	12.58	11.84
14	10.40	11.50	13.38	12.64
15	11.20	12.30	14.18	13.44
16	12.00	13.10	14.98	14.24
17	12.80	13.90	15.78	15.04
18	13.60	14.70	16.58	15.84
19	14.40	15.50	17.38	16.64
20	15.20	16.30	18.18	17.44



3	焊片 Fitting Nail	磷青铜 Phosphor Bronze	2	电镀(金): 整个表面镀底镍30u"MIN, 再镀锡0.8u"。
2	端子 Contact	磷青铜 Phosphor Bronze	n*1	电镀(金): 整个表面镀底镍30u"MIN, 再镀锡0.8u"。
1	基座 Wafer	LCP (UL94V-0)	1	本色
序号	名称	材料	数量	附注

THIS DOCUMENT IS THE SOLE PROPERTY OF BBJconn Technology Co., Ltd. Corporation AND SHOULD NOT BE USED IN WHOLE OR IN PART WITHOUT PRIOR WRITTEN PERMISSION.

PDWG.NO: 0510-1

APPD. JM\_Zheng

CHKD. LYX

DR. SGF

NAME: 针座 0.8-2P 刺破式 卧贴 米黄色

PJ. NO.: WT.17.68-73-M002

SIZE: A4 | DRW NO.:

FINISH: SEE NOTES | MAT'L.: SEE NOTES

SCALE: N/A | REV.: A0 | UNIT: mm | PAGE: 1/2

深圳市步步精科技有限公司

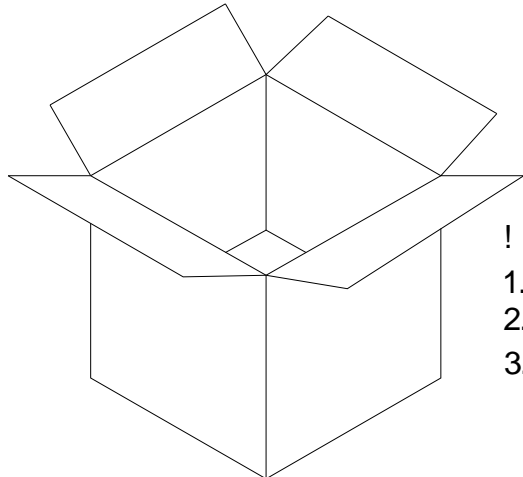
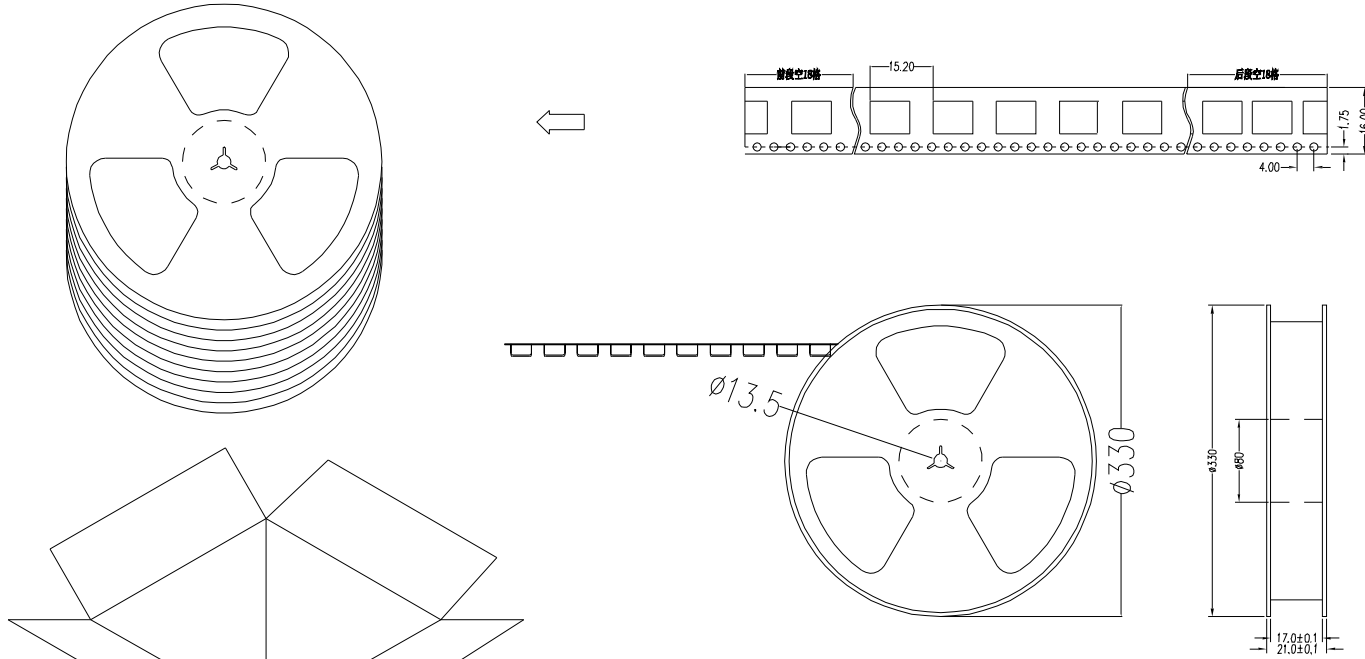

! " #  
 1. \$ % & ' #3500/ PCS/ G ( 10G /箱或15G / ) +  
 2. \$ % , - . # / G 0 1 2 3 10-204 3 5 ( 6 7 \$ % +  
 3. 材质:  
 载体: 聚丙烯 ( PS@ ( A B 10<sup>6-9</sup> C  
 D E # < F > ? PET@, A B 10<sup>6-11</sup> C  
 G # < H F > +  
 I ) J 5 # 345\*345\*23MM  
 纸箱规格: 345\*345\*35MM

THIS DOCUMENT IS THE SOLE PROPERTY OF BBJconn Technology Co.,Ltd. Corporation AND SHOULD NOT BE USED IN WHOLE OR IN PART WITHOUT PRIOR WRITTEN PERMISSION.		\$! c 2!•!•2!0 ° 9L€ œ (	
PDWG.NO: 0510-1		.X: ±0.38 .XX: ±0.25 .XXX: ±0.13	X': ±3" .X': ±2" .XX': ±1"
APPD.	JM_Zheng	NAME: Öëxù 0.8-2P 'iÆÆÉ½ îÖiü Ãx»ÆÉ«	
CHKD.	LYX	PJ. NO.: WT.17.68-73-M002	
DR.	SGF	SIZE: A4 DRW NO.:	
		FINISH: SEE NOTES MAT'L.: SEE NOTES	
		SCALE: N/A REV.: A0 UNIT: mm PAGE: 2/2	