

REV.	ECN NO.	CONTENT	DATE	ENGINEER
A0				

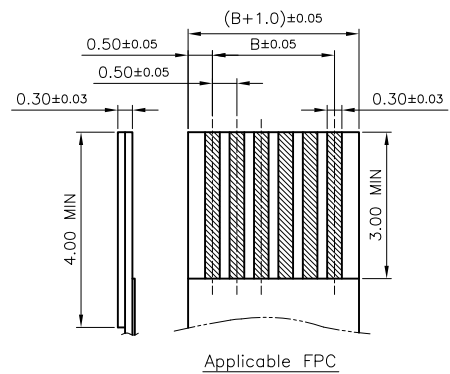

NOTES:
 1. MATERIAL:
 HOUSING: HIGHT-TEMP PLASTIC, UL 94V-0, COLOR: WHITE;
 COVER: HIGHT-TEMP PLASTIC, UL 94V-0, COLOR: BLACK;
 CONTACT: COPPER ALLOY;
 PEG: COPPER ALLOY;
 2. PLATING:
 TERMINAL: 50~100u" Nickel UNDERPLATED OVERALL.
 S: 100~160u" Matte Sn UNDERPLATED OVERALL.
 G: 1u"Min Au UNDERPLATED CONTACT/SOLDER AREA.
 T: 3u"Min Au UNDERPLATED CONTACT/SOLDER AREA.
 PEG: 50~100u" Nickel UNDERPLATED OVERALL.
 100~160u" Matte Sn PLATED ON Nickel OVERALL.
 3. RATING:
 CURRENT RATING: 0.4A AC/DC
 VOLTAGE RATING: 50V AC/DC
 TEMPERATURE RANGE: -55° C~+85° C;

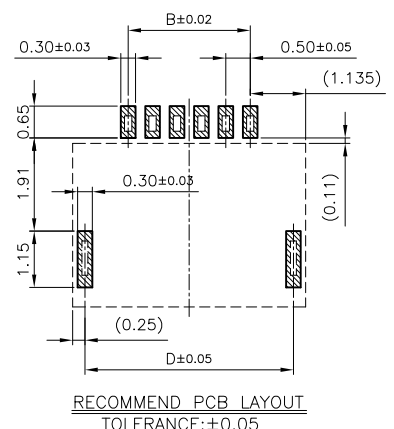
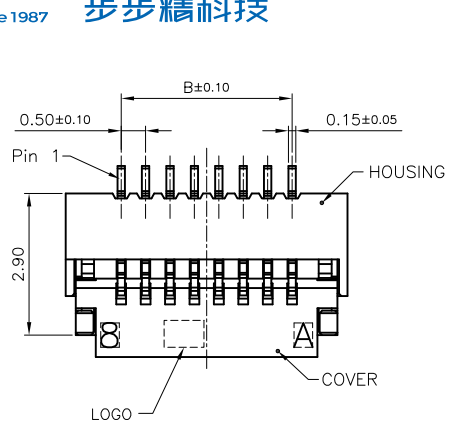
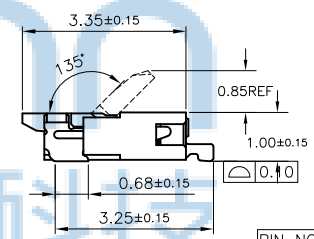
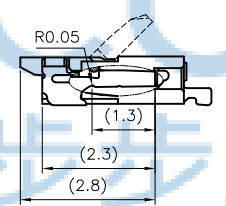
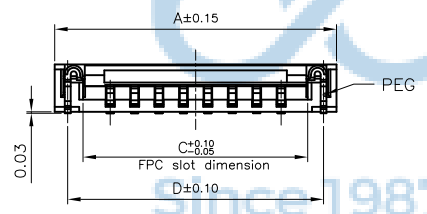

PIN NO.	DIM. A	DIM. B	DIM. C	DIM. D	PIN NO.	DIM. A	DIM. B	DIM. C	DIM. D
04	3.77	1.50	2.60	3.27	23	13.27	11.50	12.10	12.77
05	4.27	2.00	3.10	3.77	24	13.77	11.50	12.60	13.27
06	4.77	2.50	3.60	4.27	25	14.27	12.00	13.10	13.77
07	5.27	3.00	4.10	4.77	26	14.77	12.50	13.60	14.27
08	5.77	3.50	4.60	5.27	27	15.27	13.00	14.10	14.77
09	6.27	4.00	5.10	5.77	28	15.77	13.50	14.60	15.27
10	6.77	4.50	5.60	6.27	29	16.27	14.00	15.10	15.77
11	7.27	5.00	6.10	6.77	30	16.77	14.50	15.60	16.27
12	7.77	5.50	6.60	7.27	31	17.27	15.00	16.10	16.77
13	8.27	6.00	7.10	7.77	32	17.77	15.50	16.60	17.27
14	8.77	6.50	7.60	8.27	33	18.27	16.00	17.10	17.77
15	9.27	7.00	8.10	8.77	34	18.77	16.50	17.60	18.27
16	9.77	7.50	8.60	9.27	35	19.27	17.00	18.10	18.77
17	10.27	8.00	9.10	9.77	36	19.77	17.50	18.60	19.27
18	10.77	8.50	9.60	10.27	37	20.27	18.00	19.10	19.77
19	11.27	9.00	10.10	10.77	38	20.77	18.50	19.60	20.27
20	11.77	9.50	10.60	11.27	39	21.27	19.00	20.10	20.77
21	12.27	10.00	11.10	11.77	40	21.77	19.50	20.60	21.27
22	12.77	10.50	11.60	12.27	n	n*0.5+1.77	(n-1)*0.5	n*0.5+0.6	n*0.5+1.27

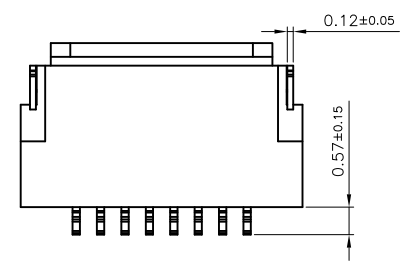

THIS DOCUMENT IS THE SOLE PROPERTY OF BBJconn Technology Co., Ltd. Corporation AND SHOULD NOT BE USED IN WHOLE OR IN PART WITHOUT PRIOR WRITTEN PERMISSION.

PDWG. NO: 0428-1

DR. LHC

APPD. JM_Zheng

CHKD. LYX

FINISH: SEE NOTES

SCALE: N/A

REV.: A3

UNIT: mm

PAGE: 1/2

NAME: FPC 0.5-5P 翻盖下接 H=1.0 (FPC0510)

PJ. NO.: PC.02.04-12-D005

SIZE: A4

DRW NO.:

MAT'L.: SEE NOTES

深圳市步步精科技有限公司

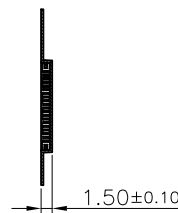
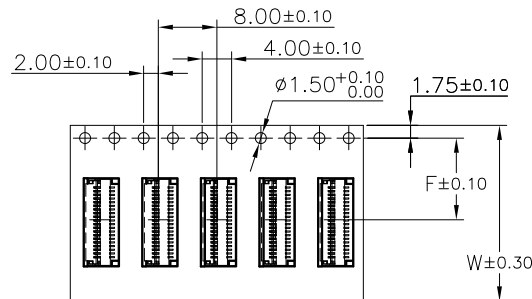
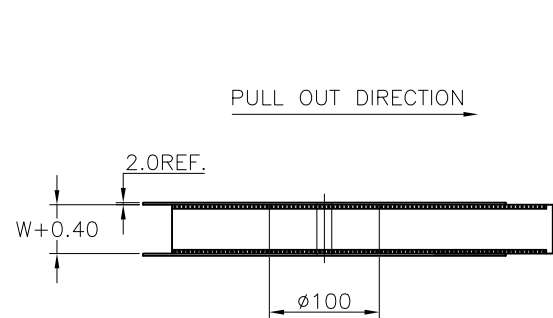

NOTES:
1. ALL DIMENSION MEET EIA-481-3 REQUIREMENTS;
2. CARRIER MATERIAL: PS, BLACK;
3. PACKING QULITY: 5000PCS/REEL;

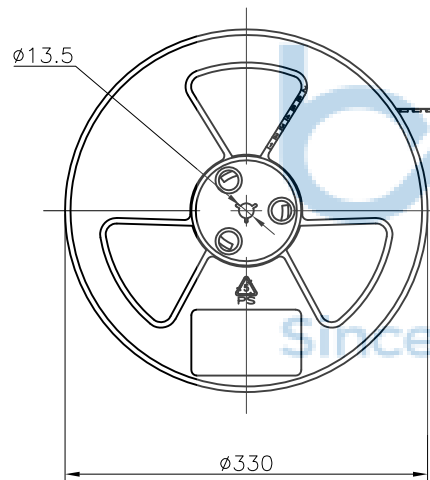

SCALE 3:20

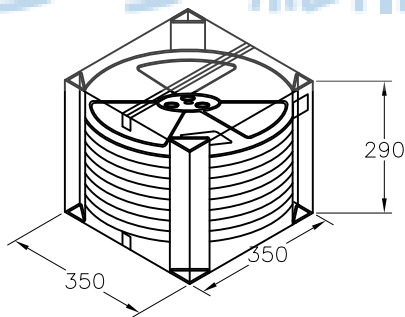
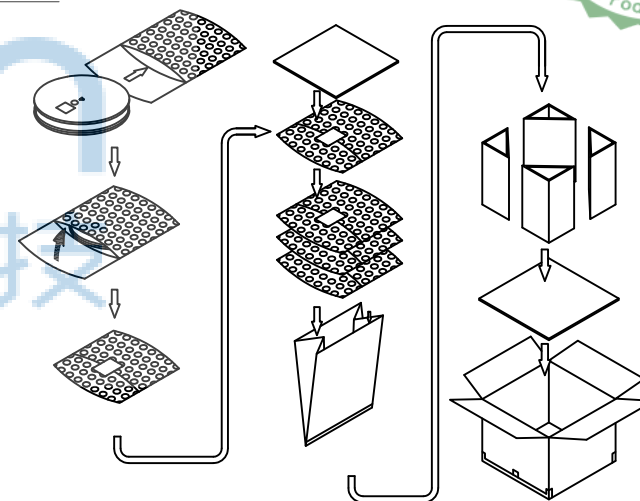
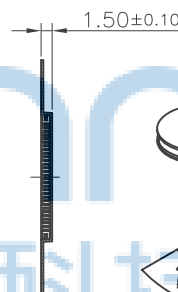
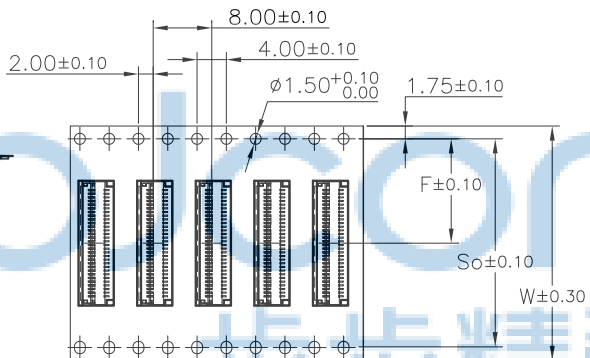

PACKING DISCRPTION:

PIN No.	04~07	08~13	14~30	31~40	41~50	PIN NO.	DIM W	DIM F	DIM So
REEL WIDTH	12.4	16.4	24.4	32.4	44.4	04~07	12.0	5.50±0.05	--
PCS/REEL	5000	5000	5000	5000	5000	08~13	16.0	7.50±0.10	--
REEL/BOX	11	9	7	6	5	14~30	24.0	11.50±0.10	--
BOX/PCS	55K	45K	35K	30K	25K	31~40	32.0	14.20±0.10	28.4
CTN. SIZE	350*350*300					41~50	44.0	20.20±0.15	40.4



THIS DOCUMENT IS THE
SOLE PROPERTY OF
BBJconn Technology Co.,Ltd.
Corporation AND SHOULD
NOT BE USED IN WHOLE
OR IN PART WITHOUT
PRIOR WRITTEN PERMISSION.
PDWG.NO: 0428-1

深圳市步步精科技有限公司

.X: ±0.38	X': ±3'	NAME:
.XX: ±0.25	X'': ±2'	FPC 0.5-5P 翻盖下接 H=1.0 (FPC0510)
.XXX: ±0.13	.XX': ±1'	PJ. NO.: PC.02.04-12-D005
APPD. JM_Zheng	SIZE: A4	DRW NO.:
CHKD. LYX	FINISH: SEE NOTES	MAT'L: SEE NOTES
DR. LHC	SCALE: N/A	REV.: A3
	UNIT: mm	PAGE: 2/2