

REV.	ECN NO	CONTENT	DATE	ENGINEER
A0				

Note:

1. Material:

- 1.1 Housing: thermoplastic high temp.UL94V-0; Color: natural.
- 1.2 Latch: thermoplastic high temp.UL94V-0; Color: black.
- 1.3 Terminal: copper alloy.
- 1.4 Fitting Nail: copper alloy.

2. Finish:

- 2.1 Terminal:  
Underplating: Au/matt Tin overall.
- 2.2 Fitting Nail:  
Underplating: matt Tin overall.

3. Product must comply HF RoHS specification.

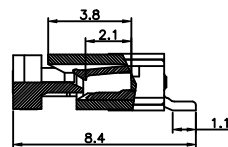
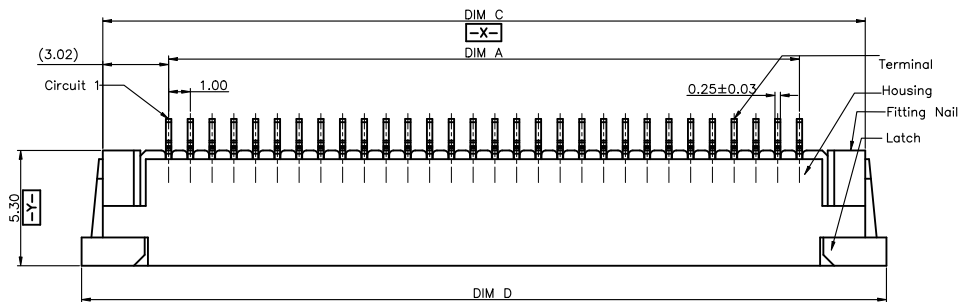

SECTION A-A  
SCALE 1:1



CKTS	DIM A	DIM B	DIM C	DIM D
4	3.00	5.10	9.05	11.00
5	4.00	6.10	10.05	12.00
6	5.00	7.10	11.05	13.00
7	6.00	8.10	12.05	14.00
8	7.00	9.10	13.05	15.00
9	8.00	10.10	14.05	16.00
10	9.00	11.10	15.05	17.00
11	10.00	12.10	16.05	18.00
12	11.00	13.10	17.05	19.00
13	12.00	14.10	18.05	20.00
14	13.00	15.10	19.05	21.00
15	14.00	16.10	20.05	22.00
16	15.00	17.10	21.05	23.00
17	16.00	18.10	22.05	24.00
18	17.00	19.10	23.05	25.00
19	18.00	20.10	24.05	26.00
20	19.00	21.10	25.05	27.00
21	20.00	22.10	26.05	28.00
22	21.00	23.10	27.05	29.00
23	22.00	24.10	28.05	30.00
24	23.00	25.10	29.05	31.00
25	24.00	26.10	30.05	32.00
26	25.00	27.10	31.05	33.00
27	26.00	28.10	32.05	34.00
28	27.00	29.10	33.05	35.00
29	28.00	30.10	34.05	36.00
30	29.00	31.10	35.05	37.00

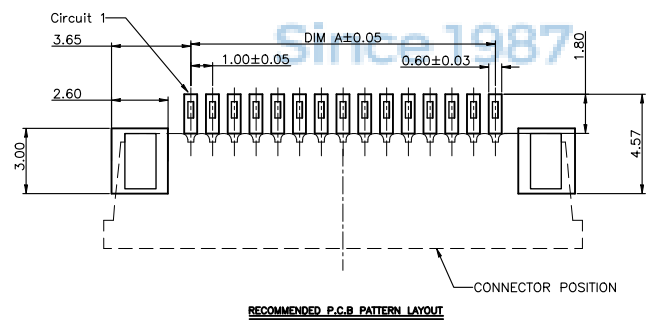
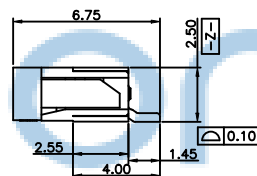
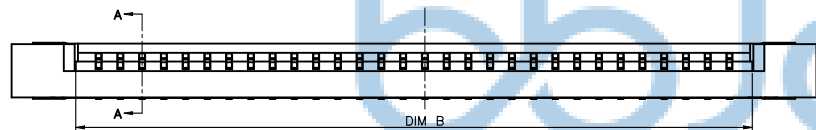

RECOMMENDED P.C.B. PATTERN LAYOUT

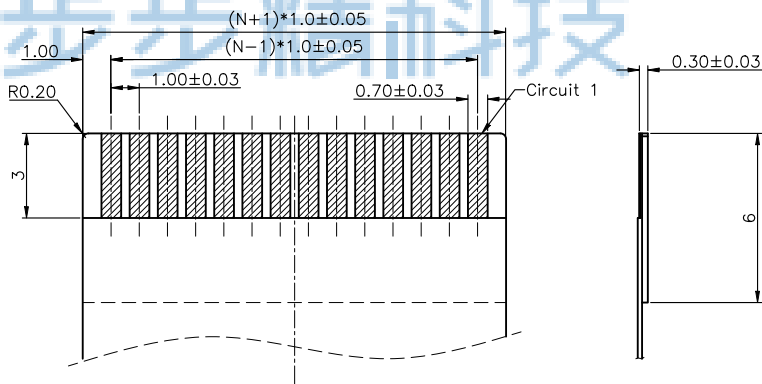

RECOMMENDED FPC/FFC DIMENSION



THIS DOCUMENT IS THE  
SOLE PROPERTY OF  
BBJconn Technology Co.,Ltd.  
Corporation AND SHOULD  
NOT BE USED IN WHOLE  
OR IN PART WITHOUT  
PRIOR WRITTEN PERMISSION.  
PDWG.NO: 0167-1

深圳市步步精科技有限公司

.X: ±0.38 X': ±3"  
.XX: ±0.25 .X': ±2"  
.XXX: ±0.13 .XX': ±1"

NAME: FPC 1.0-6P 抽拉上接 H=2.5 (AFA07)

APPD. JM\_Zheng

PJ. NO.: PC.04.01-42-2005

CHKD. LYX

SIZE: A4 DRW NO.:

DR. TSP

FINISH: SEE NOTES MAT'L.: SEE NOTES

SCALE: N/A REV.: A0 UNIT: mm PAGE: 1/2

REV.	ECN NO	CONTENT	DATE	ENGINEER
AO				

- NOTES:
1. 10 SPROCKET HOLE PITCH CUMULATIVE TOLERANCE.  $\pm 0.20\text{mm}$
  2. CARRIER CAMBER NOT TO EXCEED 1mm IN 250mm.
  3. ALL DIMENSIONS MEET EIA-481-C REQUIREMENTS.
  4. MATERIAL: BLACK ANTI-STATIC POLYSTYRENE.
  5. THICKNESS:  $0.35 \pm 0.05 \text{ mm}$ .
  6. PACKING LENGTH PER 13" REEL : 18.60METERS.
  7. COMPONENT LOAD PER 13" REEL : 1500PCS
  8. PEELING OFF FORCE OF TOP TAPE 0.1N~0.7N(10.2gf~71.4gf).

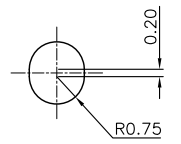
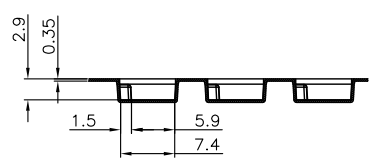
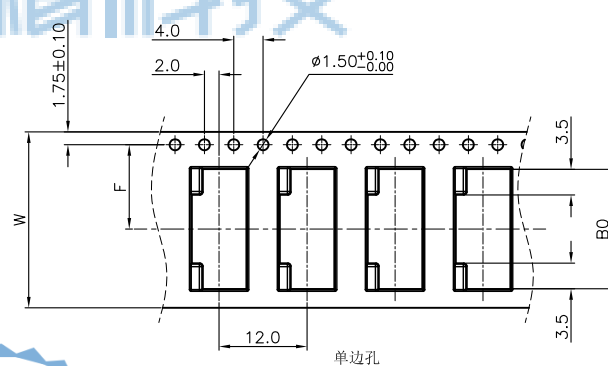
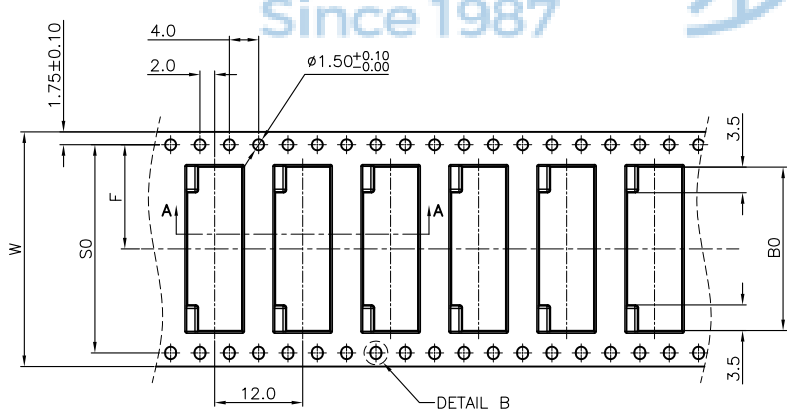
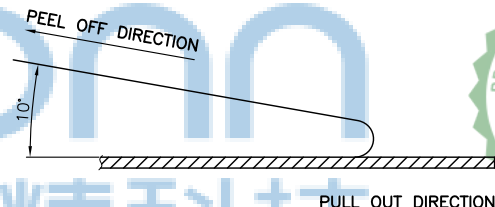
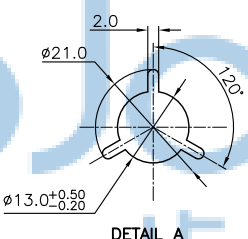
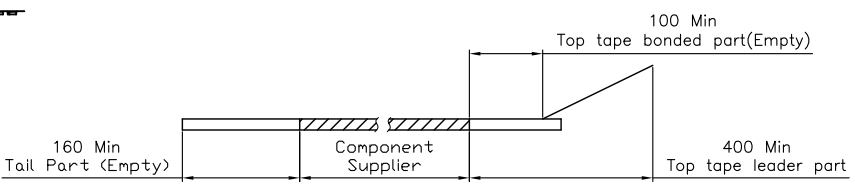
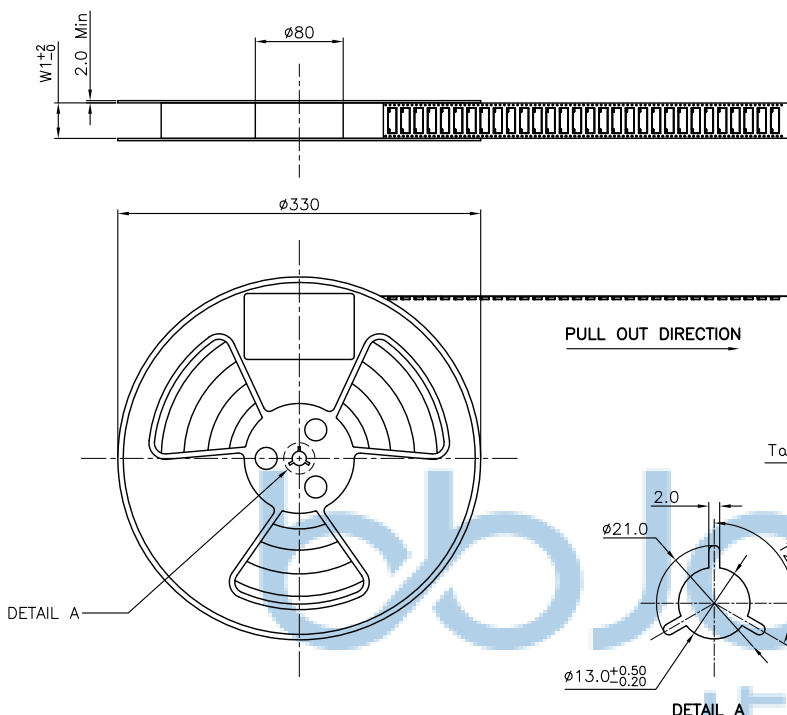

CKTS	30±0.10	W	W1	F	S0±0.10
4	11.30				
5	12.30				
6	13.30	24+0.3/-0	24.4	11.5±0.10	单边孔
7	14.30				
8	15.30				
9	16.30				
10	17.30				
11	18.30				
12	19.30	32±0.30	32.4	14.2±0.10	28.4
13	20.30				
14	21.30				
15	22.30				
16	23.30				
17	24.30				
18	25.30				
19	26.30				
20	27.30				
21	28.30	44±0.30	44.4	20.2±0.15	40.4
22	29.30				
23	30.30				
24	31.30				
25	32.30				
26	33.30				
27	34.30				
28	35.30				
29	36.30	56±0.30	56.4	26.2±0.15	52.4
30	37.30				



THIS DOCUMENT IS THE SOLE PROPERTY OF BBJconn Technology Co., Ltd. CORPORATION AND SHOULD NOT BE USED IN WHOLE OR IN PART WITHOUT PRIOR WRITTEN PERMISSION.

PDWG.NO: 0167-1

APPD. JM\_Zheng  
CHKD. LYX  
DR. TSP

NAME: FPC 1.0-6P 抽拉上接 H=2.5 (AFA07)

PJ. NO.: PC.04.01-42-2005  
SIZE: A4 DRW NO.:

FINISH: SEE NOTES MAT'L.: SEE NOTES  
SCALE: N/A REV.: AO UNIT: mm PAGE: 2/2

深圳市步步精科技有限公司