

NOTES:

- MATERIALS:
 - HOUSING: THERMOPLASTIC (UL94V-0)
 - TERMINAL: COPPER ALLOY.GOLD PLATED ON CONTACT AREA.
 - SHELL: COPPER ALLOY,NICKEL PLATED OVERALL.
- SPECIFICATION
 - INSERT FORCE: 44.1N MAX
 - WITHDRAWAL FORCE: 9.8N MIN, 39.2N MAX
 - MATING CYCLE:5000 CYCLES
 - RATING CURRENT: 0.5A
 - RATING VOLTAGE: 40V
 - CONTACT RESISTANCE: 10 MILLIOHMS MAX (EXCLUDING CONDUCTOR RESISTANCE)
 - INSULATION RESISTANCE:
 - UNMATED: 100M OHMS MIN AT 500V DC
 - MATED: 10M OHMS MIN AT 150V DC
 - DIELECTRIC WITHSTANDING VOLTAGE: 500V AC/1MINUTE
 - OPERATING TEMPERATURE: -20°C--+85°C
 - STORAGE TEMPERATURE: -20°C--+65°C
 - P/N: HD.01.51-21-G001
 - FINISH SEE TABLE
 - REVISE : Δ REVISE POSITION.

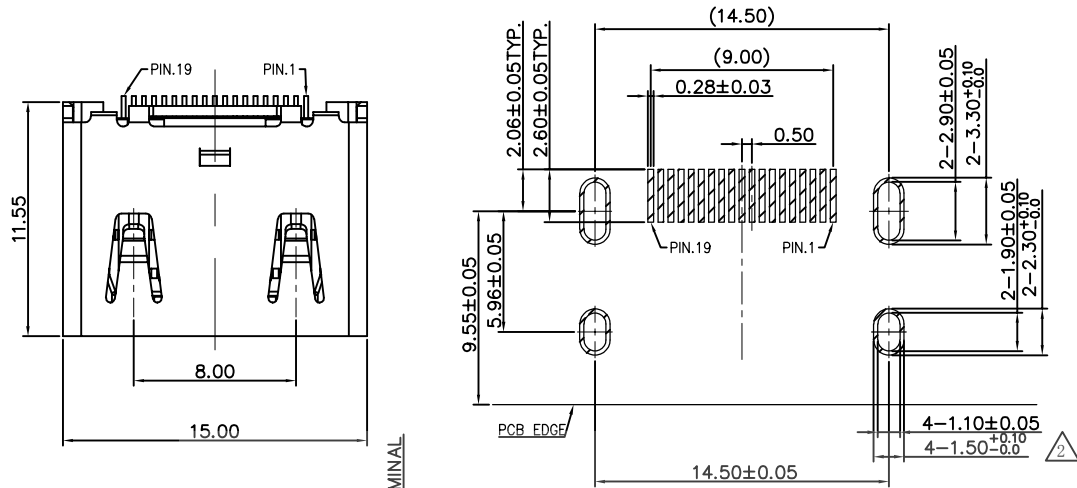

RECOMMEND P.C.B LAYOUT(COMPONENT SIDE)
TOLERANCE FOR PCB LAYOUT IS ± 0.05

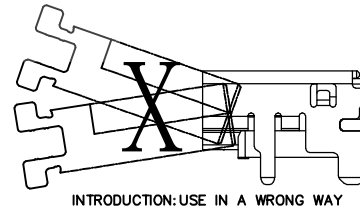
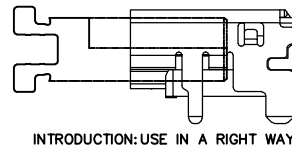
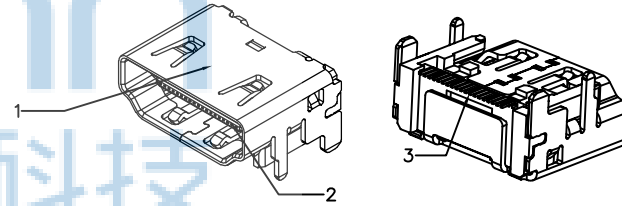
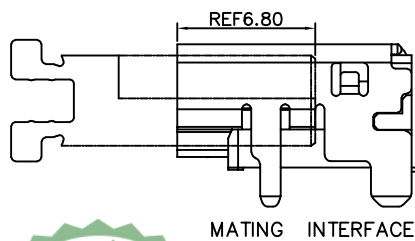
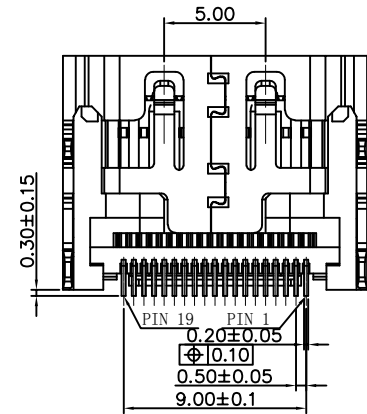
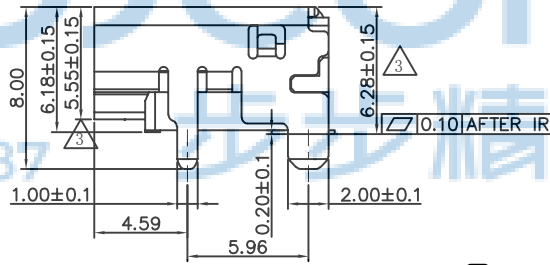
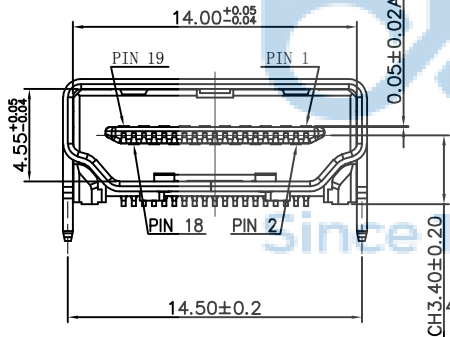

TABLE				
ITEM	PART NAME	QTY	MATERIAL	REMARK
1	SHELL	1PCS	COPPER ALLOY	NICKEL PLATED 30" MIN. OVER ALL
2	INSERT HOUSING	1PCS	LCP	UL94V-0
3	CONTACT	1SET	COPPER ALLOY	NI PLATED 30" MIN OVER ALL. GOLD 1u"ON CONTACT AREA. Sn PLATED 100u" MIN ON SOLDER MNTA



PIN	Signal Assignment	PIN	Signal Assignment
1	TMDS Data2+	2	TMDS Data2 Shield
3	TMDS Data2-	4	TMDS Data1+
5	TMDS Data1 Shield	6	TMDS Data1-
7	TMDS Data0+	8	TMDS Data0 Shield
9	TMDS Data0-	10	TMDS Clock+
11	TMDS Clock Shield	12	TMDS Clock-
13	CEC	14	Utility
15	SCL	16	SDA
17	DDC/CEC_Ground	18	+5V Power
19	Hot Plug Detect		

THIS DOCUMENT IS THE SOLE PROPERTY OF BBJconn Technology Co.,Ltd.

Corporation AND SHOULD NOT BE USED IN WHOLE OR IN PART WITHOUT PRIOR WRITTEN PERMISSION.
PDWG.NO: 9999-9

深圳市步步精科技有限公司

.X: ± 0.38	X': $\pm 3'$	NAME:
.XX: ± 0.25	.X': $\pm 2'$	HDMI A型四脚插板上型平口镀镍铜壳端子SMT脚长1.95mm
.XXX: ± 0.13	.XX': $\pm 1'$	APPD. JM_Zheng
		SIZE: A4 DRW NO.:
		FINISH: SEE NOTES
		MAT'L.: SEE NOTES
		SCALE: N/A
		REV.: A0
		UNIT: mm
		PAGE: 1/2

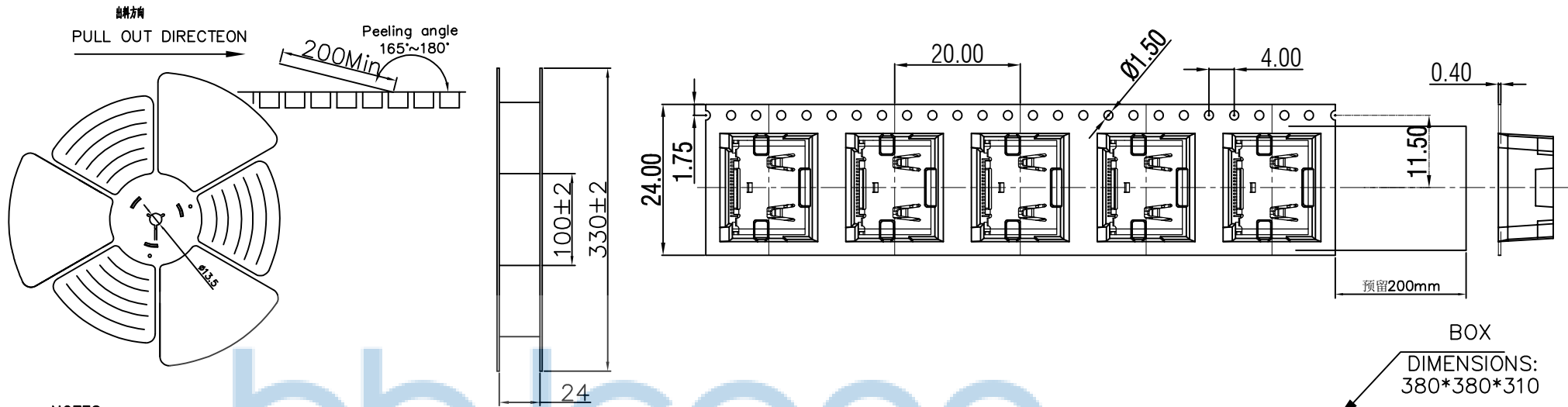

NOTES

1. 带子引导长度
LEAD TAPE LENGTH
出料方向
PULL OUT DIRECTEON

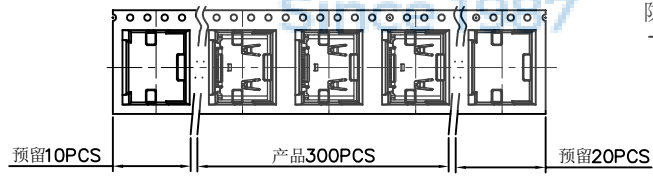

2. 上带剥离力: 0.1~1.3N (10.2gf~130gf)
PEELING OFF FORCE OF TOP TAPE: 0.1~1.3N (10.2gf~130gf)
出货运输过程中一定注意:
THIS REQUIREMENT SHOULD BE APPLIED AT SHIPMENT:
卷带在运输过程中不能散开
PEELING OFF SHOULD NOT BE ALLOWED DURING TRANSPORTATION

防水袋2个+4包干燥剂+三角板

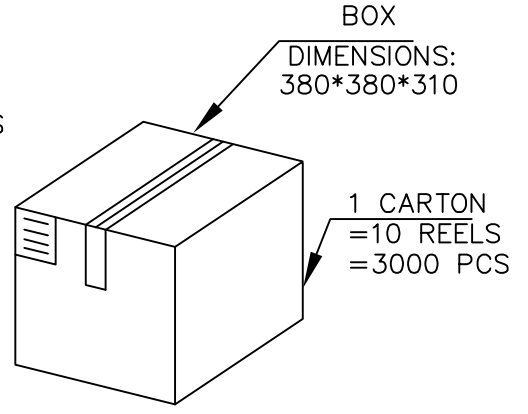
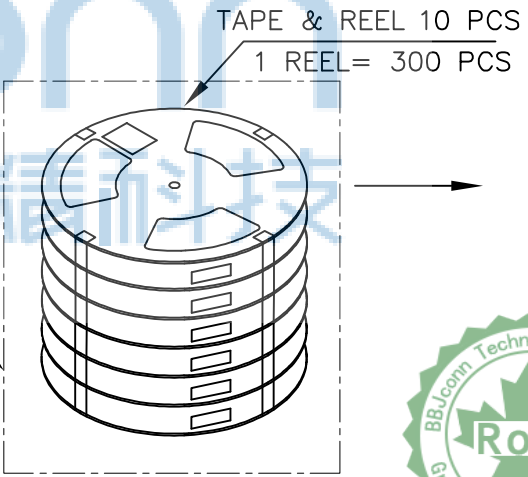

包装明细表 (The detail of the packing) Carton						
产品料号 (Product No.)	包装容量 (Packing Capacity)			重量 Weight (Kg)		
	pcs/box	boxs/Carton	Pcs/Box	N.W./Pcs	N.W./Box	G.W./Box
HD. 01. 51-21-G001	300	10	3000	----	6.25KG	10.5KG

THIS DOCUMENT IS THE SOLE PROPERTY OF BBJconn Technology Co.,Ltd. Corporation AND SHOULD NOT BE USED IN WHOLE OR IN PART WITHOUT PRIOR WRITTEN PERMISSION.		深圳市步步精科技有限公司	
.X: ±0.38 .XX: ±0.25 .XXX: ±0.13		NAME: HDMI A型四脚插板上型平口镀镍铜壳端子SMT脚长1.95mm APPD. JM_Zheng CHKD. LYX DR. SGF PDWG.NO: 9999-9	
X': ±3' .X': ±2' .XX': ±1'		PJ. NO.: HD. 01. 51-21-G001 SIZE: A4 DRW NO.: FINISH: SEE NOTES MAT'L.: SEE NOTES SCALE: N/A REV.: A0 UNIT: mm PAGE: 2/2	