

REV.	ECN NO	CONTENT	DATE	ENGINEER
A0				

Notes:

- Materials
 - Housing: LCP+30% G/F, Black, UL94 V-0;
 - Contact: Phosphor Copper (C5191), Gold Plating at mating area, Matte Tin or Au Plating at solder tail, all over Nickel;
 - Shell: Phosphor Copper (C5191);
- Ratings
 - Current Rating: 0.3A ;
 - Operating Temperature: -40° C ~ 85° C;
- Electrical Requirement:
 - LLCR: Excluding Conductor Resistance 10mΩ Max.(Target design value), Contact: 30mΩ Max. changed (Final), Shell: 50mΩ Max. Changed (Final);
 - Dielectric Withstanding Voltage: 150V AC (RMS) for 1 minute (Mated), 250V AC (RMS) for 1 minute (Unmated);
 - Insulation Resistance: 10MΩ Min. @ 150V DC (Mated), 100MΩ Min. @ 500V DC (Unmated);
- Mechanical Performance:
 - Insertion force: 44.1N (4.5Kgf) Max.;
 - Withdrawal force: 4.9~25N (0.5~2.5Kgf);
 - Durability life: 5,000 Cycles;
- IR Reflow: the peak temperature on board shall be maintained for 10 seconds at 260±5° c.
- Shell plating code : Plating Nickel
Contact plating code: Mating area G/F, Solder tail Matte Tin;

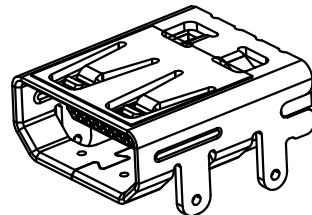
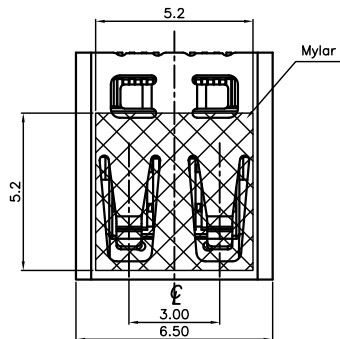
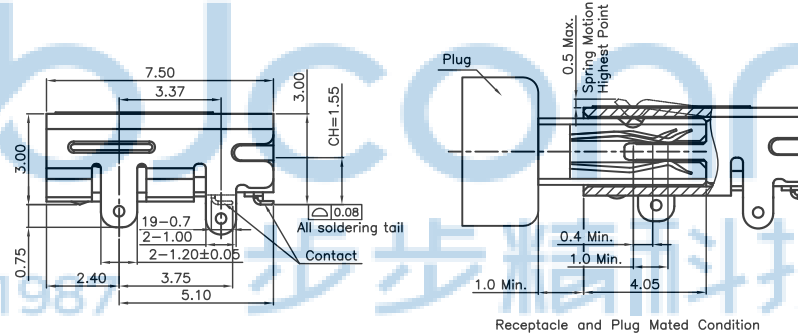
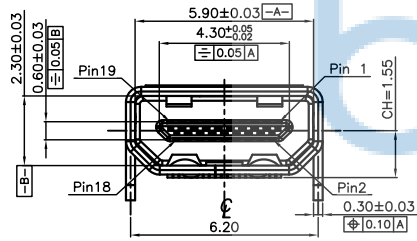
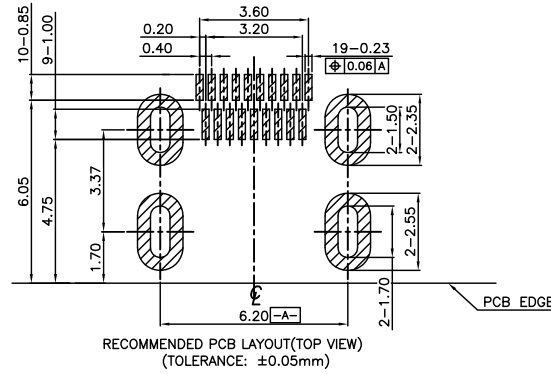
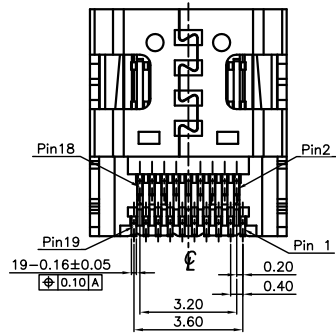

PIN	Signal Assignment
1	Hot Plug Detect
2	Utility
3	TMDS Data2+
4	TMDS Data2 Shield
5	TMDS Data2-
6	TMDS Data1+
7	TMDS Data1 Shield
8	TMDS Data1-
9	TMDS Data0+
10	TMDS Data0 Shield
11	TMDS Data0-
12	TMDS Clock+
13	TMDS Clock Shield
14	TMDS Clock-
15	CEC
16	DDC/CEC Ground
17	SCL
18	SDA
19	+5V Power

THIS DOCUMENT IS THE SOLE PROPERTY OF BBJconn Technology Co.,Ltd. Corporation AND SHOULD NOT BE USED IN WHOLE OR IN PART WITHOUT PRIOR WRITTEN PERMISSION. PDWG.NO: 0301-1	深圳市步步精科技有限公司	
	.X: ±0.38 .X': ±3" .XX: ±0.25 .X'': ±2" .XXX: ±0.13 .X''': ±1"	NAME: HDMI 母座 19P 板上四脚插 L=7.50 CH=1.55 平口 LCP黑胶 铜壳 端子双排SMT
	APPD. JM_Zheng CHKD. LYX DR. SGF	PJ. NO.: HD.01.51-24-B002 SIZE: A4 DRW NO.: FINISH: SEE NOTES MAT'L.: SEE NOTES SCALE: N/A REV.: A0 UNIT: mm PAGE: 1/2

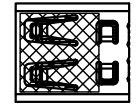
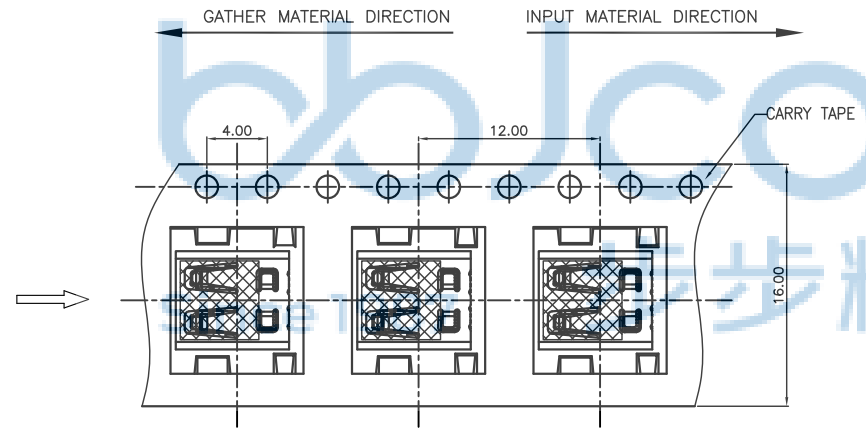
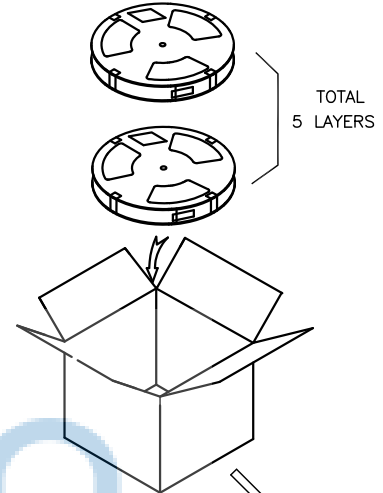
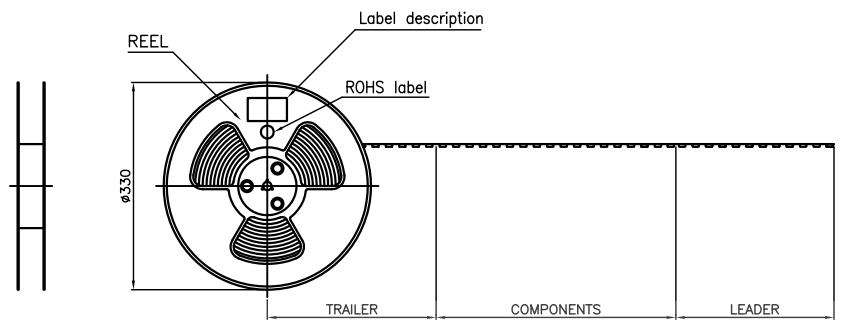

HDMI

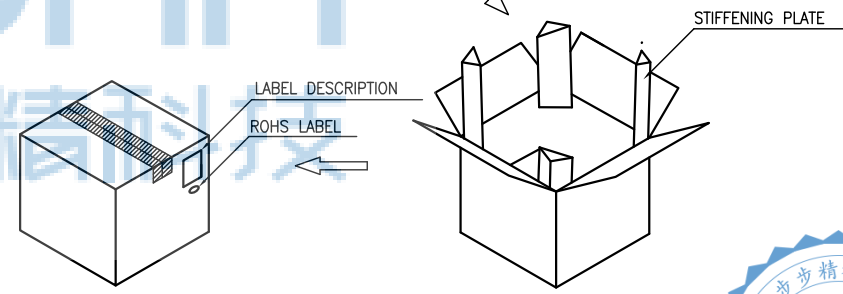

- Notes:
1. The start and end of each reel, based on the actual quantity, reserved 10--15pcs space;
 2. Peel off force of top tape: 10g~130g, peel deg.:165°~175° ; peel speed: 250~300mm/min;
 3. Carton size: 34*34*4mm.
 4. QTY: 1000pcs/reel, 5reel/carton, total 5000pcs/carton;

THIS DOCUMENT IS THE SOLE PROPERTY OF BBJconn Technology Co.,Ltd. Corporation AND SHOULD NOT BE USED IN WHOLE OR IN PART WITHOUT PRIOR WRITTEN PERMISSION.		深圳市步步精科技有限公司	
.X: ±0.38 .XX: ±0.25 .XXX: ±0.13		X*: ±3" .X*: ±2" .XX*: ±1"	
APPD. JM_Zheng		NAME: HDMI 母座 19P 板上四脚插 L=7.50 CH=1.55 平口 LCP黑胶 铜壳 端子双排SMT	
CHKD. LYX		PJ. NO.: HD.01.51-24-B002	
DR. SGF		SIZE: A4 DRW NO.:	
PDWG.NO: 0301-1		FINISH: SEE NOTES MAT'L.: SEE NOTES	
		SCALE: N/A REV.: A0 UNIT: mm PAGE: 2/2	