

REV.	ECN NO.	CONTENT	DATE	ENGINEER
A0				

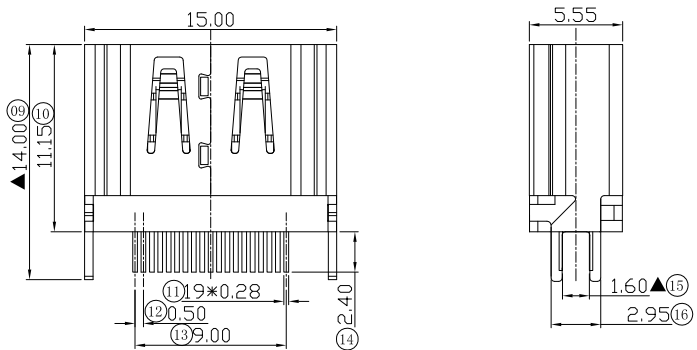

SPECIFICATION

- Electrical characteristics**
 Contact Current Rating: 0.5 A
 Dielectric Withstanding Voltage: 300V AC
 Insulation Resistance: a. Mate 100MΩ MIN at 500V/DC
 b. Unmate 10MΩ MIN at 150V/DC
 Contact Resistance: 30mΩ MAX
 Temperature Range: -20° C to +85° C
- Mechanical**
 Mating Face: 44.1N MAX
 Unmating Face: 9.8N MIN; 39.2N MAX
 Durability: 5000 Cycles
- material:**
 HOUSING: THERMOPLASTICS HIGH TEMP LCP+GLASS
 FIBER BLACK COLOR, UL94V-0
 CONTACT: Copper Alloy, T=0.20MM
 SHELL: Copper Alloy (SPCC), T=0.50MM
- PLATING:**
 CONTACT: 1~30u" GOLD/TIN PLATING ON CONTACT AREA
 100u" MIN, TIN PLATING ON SOLDER TAILS
 50u" MIN, NICKEL UNDERPLATING OVER ALL
 SHELL: 80u", NICKEL UNDERPLATING OVER ALL

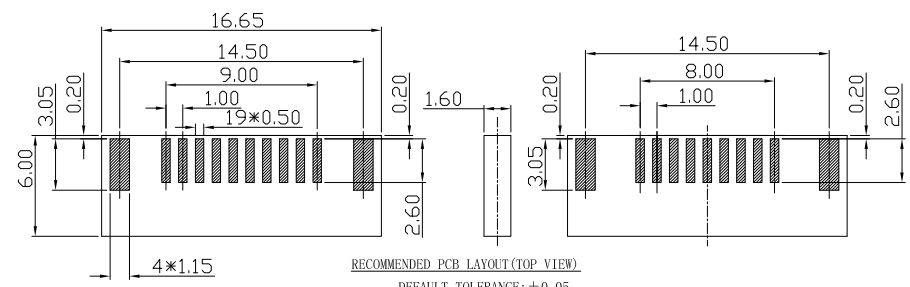
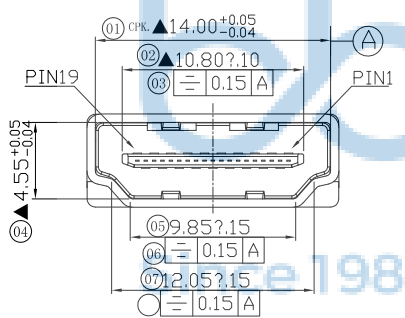

THIS DOCUMENT IS THE SOLE PROPERTY OF BBJconn Technology Co., Ltd. Corporation AND SHOULD NOT BE USED IN WHOLE OR IN PART WITHOUT PRIOR WRITTEN PERMISSION.		深圳市步步精科技有限公司	
PDWG.NO: 0301-1	APPD. JM_Zheng	NAME: HDMI A-TYPE 母座 直立夹板1.65 H=11.05 铁壳 LCP黑胶 (壳0.5厚)	PJ. NO.: HD.01.61-14-B001
	CHKD. LYX	SIZE: A4	DRW NO.:
	DR. SGF	FINISH: SEE NOTES	MAT'L.: SEE NOTES
		SCALE: N/A	REV.: A0
		UNIT: mm	PAGE: 1/2

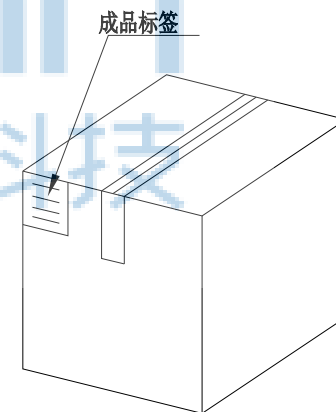
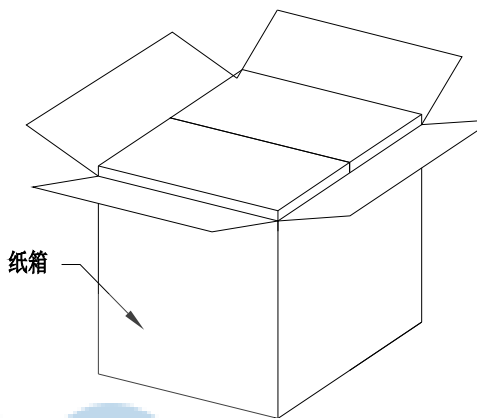
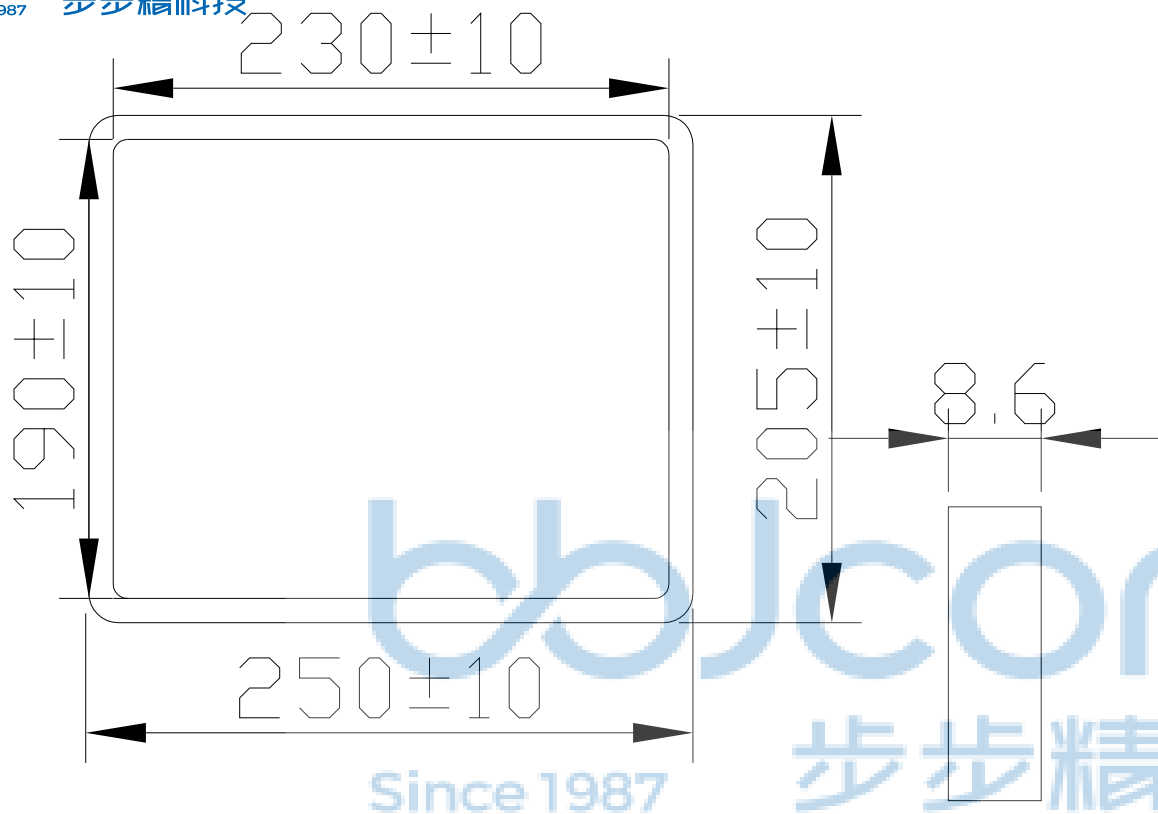

纸箱规格: 350*210*290

1. 包装要求:

- 1.1 每盒吸塑盒包装100 pcs;
- 1.2 每20盘放一箱, 共计2000PCS;
- 1.3 纸箱外贴上标签



THIS DOCUMENT IS THE SOLE PROPERTY OF BBJconn Technology Co.,Ltd. Corporation AND SHOULD NOT BE USED IN WHOLE OR IN PART WITHOUT PRIOR WRITTEN PERMISSION.		深圳市步步精科技有限公司 .X: ±0.38 .X': ±3" .XX: ±0.25 .X'': ±2" .XXX: ±0.13 .X''': ±1"		NAME: HDMI 母座 180度 H=11.05 端子 DIP 平口 铜壳 (壳0.5厚)	
APPD.	JM_Zheng	PJ. NO.: HD.01.61-14-B001 SIZE: A4 DRW NO.:		FINISH: SEE NOTES MAT'L.: SEE NOTES	
CHKD.	LYX	PDWG.NO: 0301-1		SCALE: N/A REV.: A0 UNIT: mm PAGE: 2/2	
DR.	SGF				