

REV.	ECN NO.	CONTENT	DATE	ENGINEER
AO				

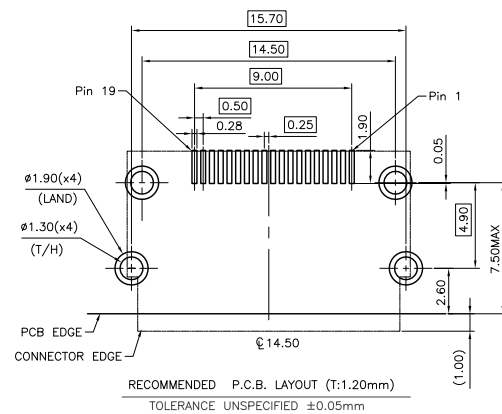

- SERIES NO.
51: HDMI CONNECTOR
- TAIL CONSTRUCTION TYPE
U: SMT TYPE
- NUMBER OF PIN
019: 19 POSITIONS
- CONTACT & CONNECTION TYPES:
S: SOCKET
- COLOR CODES
3: BLACK
- CONTACT PLATING:
4: GOLD FLASH ALLOVER OVER NICKEL
5: SELECTIVE 15u" GOLD IN CONTACT AREA AND GOLD FLASH ALLOVER OVER NICKEL
11: SELECTIVE 5u" GOLD IN CONTACT AREA AND 4u" GOLD IN SOLDER AREA
12: SELECTIVE 5u" GOLD IN CONTACT AREA AND 1.2u" GOLD IN SOLDER AREA, OTHER AREA PLATING NICKEL
13: 1.5u" GOLD OVER NICKEL
- SHELL CONSTRUCTION
HF: HIGH PROFILE WITHOUT RIBBING, WITHOUT FLANGE, WITH SPRING LATCH
SHELL IS FOUR TAILS THROUGH HOLE TYPE
THE FRONT LEG IS FOLDS BACKWARD
- SHELL PLATING
T: TIN PLATED (LEAD FREE)
N: SOLDERABLE NICKEL PLATED
- PACKAGING
R: TAPE REEL PACKING
- SHELL MATERIAL & SHELL LEG CODE
D: SHELL MATERIAL IS BRASS, LEG LENGTH L IS 3.2mm
F: SHELL MATERIAL IS BRASS, LEG LENGTH L IS 2.4mm

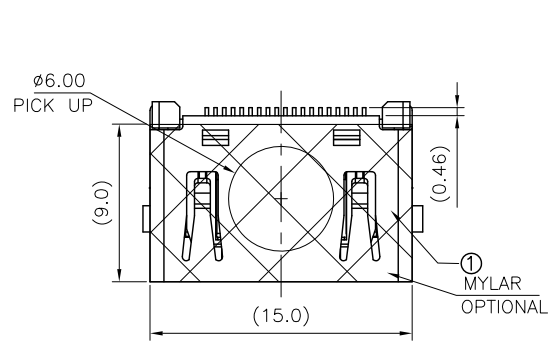
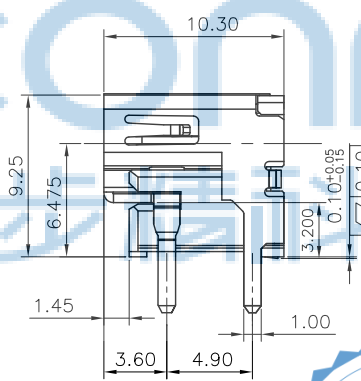
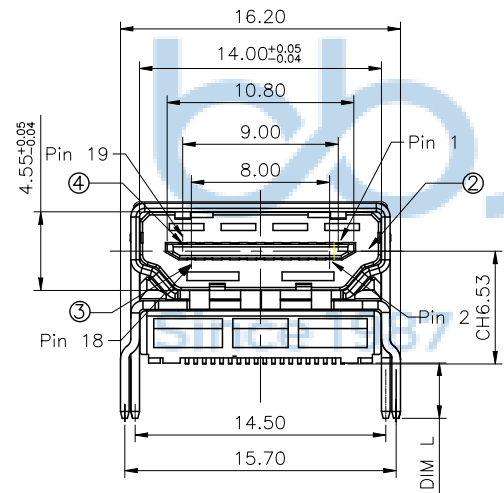

- SPECIFICATIONS**
- MECHANICAL :
 - INSERTION FORCE : 44.1 N MAX
 - WITHDRAWAL FORCE : 9.8 N MIN.
 - ELECTRICAL :
 - CONTACT CURRENT RATING: 0.5A MIN.
 - VOLTAGE RATING : 40V AC (rms)
 - WITHSTANDING VOLTAGE:
500Volts AC BETWEEN ADJACENT TERMINAL (UNMATE)
300Volts AC BETWEEN ADJACENT TERMINAL (MATE)
 - INSULATION RESISTANCE:
100Mohm MIN. (UNMATED); 10Mohm MIN. (MATED)
 - CONTACT RESISTANCE: 30 MILLIOHMS MAX.
 - ENVIRONMENTAL :
 - OPERATING TEMPERATURE: -25° C TO +85° C



10	COPPER ALLOY	UP CONTACT	④
9	COPPER ALLOY	DOWN CONTACT	③
1	THERMOPLASTIC UL94V-0	HOUSING	①
1	COPPER ALLOY	SHELL	②
QTY'S	SPECIFICATION	PART	ITEM

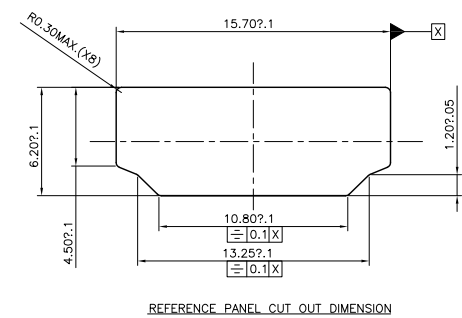
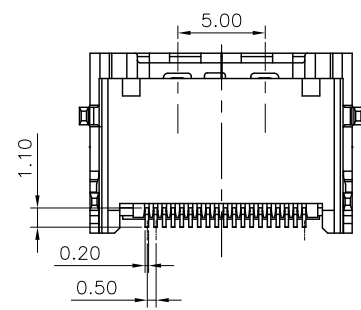

THIS DOCUMENT IS THE SOLE PROPERTY OF BBJconn Technology Co., Ltd. CORPORATION AND SHOULD NOT BE USED IN WHOLE OR IN PART WITHOUT PRIOR WRITTEN PERMISSION.

PDWG NO: 0295-1

APPD. JM_Zheng
CHKD. LYX
DR. SGF

深圳市步步精科技有限公司

NAME: HDMI 19P 母座 板上型 L=10.30 垫高 3.2 铜壳 平口 (端子 SMT)

PJ. NO.: HD.01.51-24-J001
SIZE: A4 | DRW NO.:

FINISH: SEE NOTES | MAT'L.: SEE NOTES
SCALE: N/A | REV.: A0 | UNIT: mm | PAGE: 1/2

REV.	ECN NO	CONTENT	DATE	ENGINEER
A0				

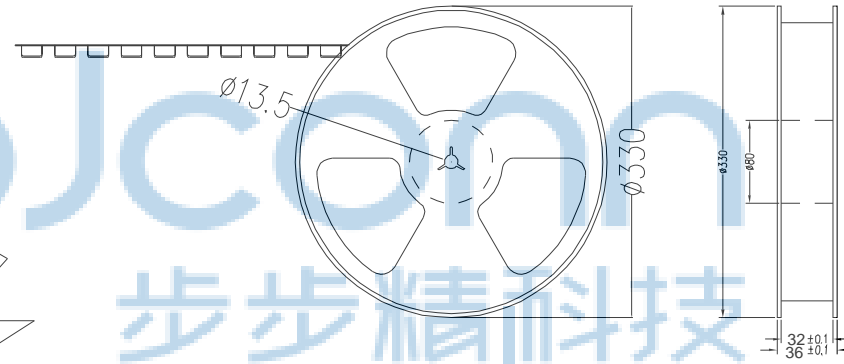
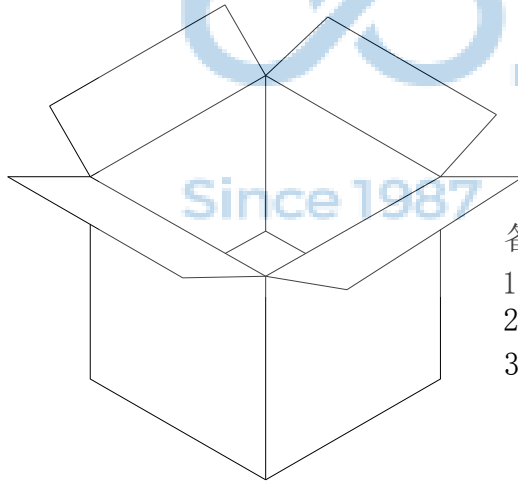
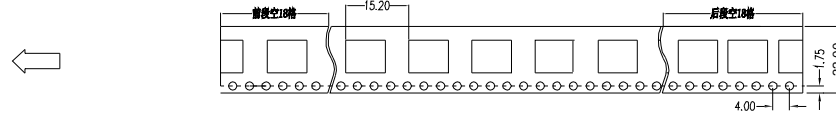
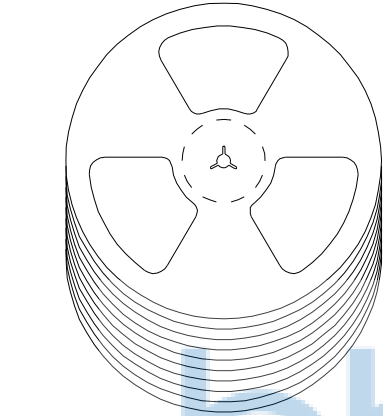

备注:

1. 包装数量: 300 /PCS/卷, 8 卷/箱
2. 包装袋长度: 每卷前空18穴, 后空18穴, 中间包装。
3. 材质:
载体: 聚丙烯 (PS), 阻抗 $10^{6-9} \Omega$
上带: 聚乙烯 (PET), 阻抗 $10^{6-11} \Omega$
卷盘: 聚苯乙烯。

纸箱规格: 345*345*23MM

纸箱规格: 345*345*35MM



THIS DOCUMENT IS THE SOLE PROPERTY OF BBJconn Technology Co.,Ltd. Corporation AND SHOULD NOT BE USED IN WHOLE OR IN PART WITHOUT PRIOR WRITTEN PERMISSION.		深圳市步步精科技有限公司 .X: ±0.38 .X': ±3' .XX: ±0.25 .X': ±2' .XXX: ±0.13 .XX': ±1'		NAME: HDMI 19P 母座 板上型L=10.30 垫高3.2 铜壳 平口 (端子SMT)	
APPD.	JM_Zheng	PJ. NO.: HD.01.51-24-J001 SIZE: A4 DRW NO.:		FINISH: SEE NOTES MAT'L.: SEE NOTES	
CHKD.	LYX	SCALE: N/A		REV.: A0	UNIT: mm
PDWG.NO:	0295-1	DR.	SGF	PAGE: 2/2	