

REV.	ECN NO	CONTENT	DATE	ENGINEER
A0		Initial release	/	TSP

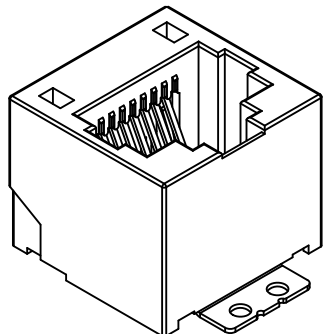

.NOTES  
ELECTRICAL  
1. VOLTAGE RATING : 125 VAC RMS.  
2. CURRENT RATING : 1.5 AMP.  
3. CONTACT RESISTANCE : 40 MILLIOHMS MAX.  
4. INSULATION RESISTANCE : 500 MEGOHMS MIN @ 100V DC .  
5. DIELECTRIC DIELECTRIC RESISTANCE : 500V DC RMS 50Hz. 1MIN.

.MECHANICAL  
1. DURRABILITY : 750 CYCLES MIN.  
2. MATING/UNMATING FORC: 2.24 KG. F MAX.

. ENVIRONMENTAL:  
1. OPERATION : -40°C~+85°C.  
2. STORAGE : -40°C~+85°C.

.THE DIMENSIONS WITH "M" ARE CRITICAL AND SHOULD BE CONTROLLED BY QC.

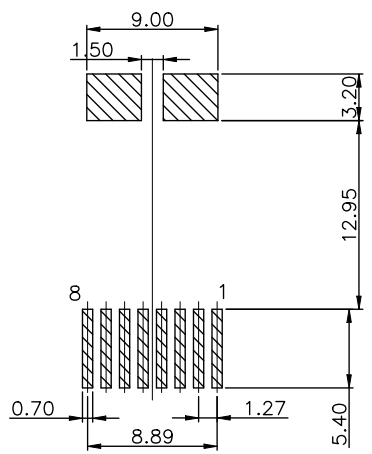
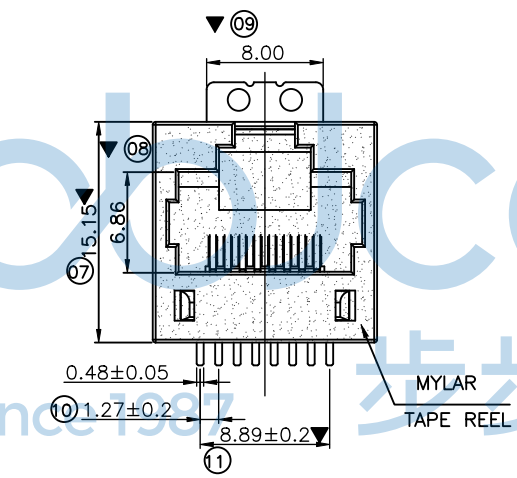
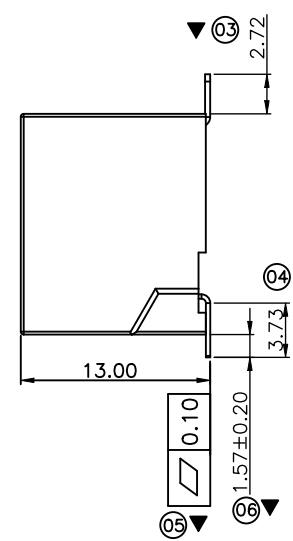
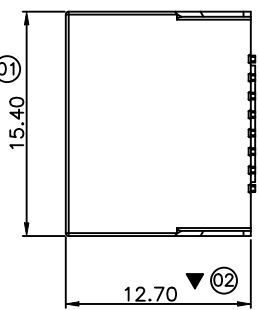

PCBLAYOUT T=1.6  
TOL:±0.05(TOP VIEW)

. PIN ASSIGNMENT:

PIN	NAME	DESCRIPTION
1	TX+	D1+ Tranceive Data+
2	TX-	D1- Tranceive Data-
3	RX+	D2+ Tranceive Data+
4	BI	D3+ Bi-directional data+
5	BI	D3- Bi-directional data-
6	RX-	D2- Tranceive Data-
7	BI	D4+ Bi-directional data+
8	BI	D4- Bi-directional data-

4	Board Lock	1	SPCC, T=0.35mm	NI 50u"
3	TERMINAL	8	C5191 T=0.30mm	Au Fu"/亮锡100u" /NI 50u"
2	INSERT MOLDING	1	LCP UL94V-0	BLACK
1	HOUSING	1	LCP UL94V-0	BLACK
NO.	PART NAME	Q' TY	MATERIAL	PLATING & COLOR

THIS DOCUMENT IS THE SOLE PROPERTY OF **BBJconn Technology Co.,Ltd.**  
Corporation AND SHOULD NOT BE USED IN WHOLE OR IN PART WITHOUT PRIOR WRITTEN PERMISSION.  
PDWG,NO: 0642-1

**深圳市步步精科技有限公司**

NAME: 网络接口 RJ45 1x1 8P8C 180度 短体 H=12.7  
无灯 无弹 全塑 SMT LCP黑色 半金锡FU 贴麦拉 载带

APPD. JM\_Zheng  
CHKD. LYX  
DR. TSP

PJ. NO.: RJ.02.12-11-A002  
SIZE: A4 | DRW NO.:  
FINISH: SEE NOTES | MAT'L.: SEE NOTES  
SCALE: N/A | REV.: A0 | UNIT: mm | PAGE: 1/2

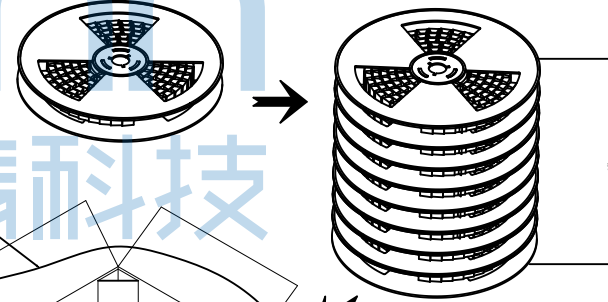
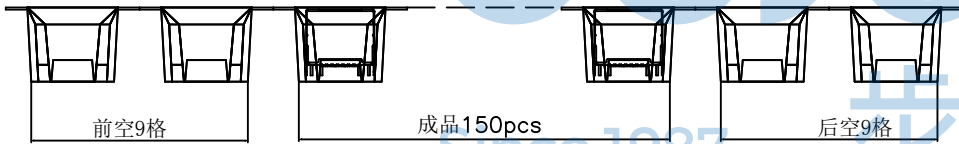
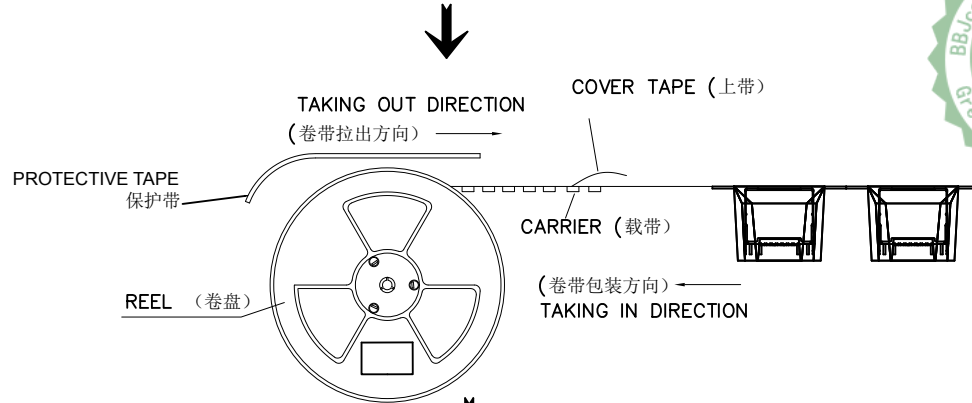
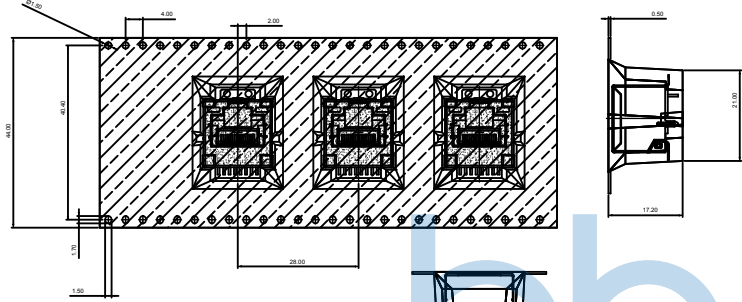
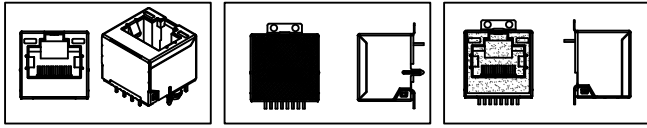

- NOTES:
1. 每卷前空9pcs,后空9pcs, 中间包装150pcs产品, 尾部用美纹胶纸封住。
  2. 外圈再卷一圈保护带, 保护带最后重叠50mm Min, 同样用美纹胶封住。
  3. 每8卷盘装入1个外箱, 外箱角落用三角板填充, 用透明胶将外箱封口。
  4. 尾数箱用纸壳或者其他填充满或者将纸箱割小至刚好装下后再封箱。
  5. 在搬运过程中要轻拿轻放。
  6. 在运输过程中不可堆叠超过五箱的高度, 不可有重压现象。
  7. 如有客户需要, 将对应打印好的标签贴于外箱侧面右上角。
- 注: 如遇客户特殊要求请参照业务出货资料。

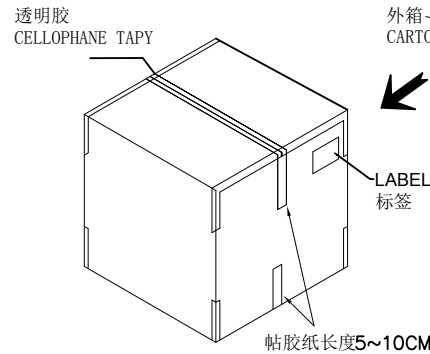

包装信息:  
包装数量: 150pcs/卷; 1200pcs/箱;  
卷盘尺寸: 15寸 即OD=38cm±2cm  
外箱尺寸: L39cm\*W39cm\*H40.5cm

THIS DOCUMENT IS THE SOLE PROPERTY OF BBJconn Technology Co.,Ltd. CORPORATION AND SHOULD NOT BE USED IN WHOLE OR IN PART WITHOUT PRIOR WRITTEN PERMISSION.		<b>深圳市步步精科技有限公司</b>	
PDWG.NO: 0642-1		.X: ±0.38 .XX: ±0.25 .XXX: ±0.13	X': ±3" .X': ±2" .XX': ±1"
APPD.	JM_Zheng	NAME: 网络接口 RJ45 1x1 8P8C 180度 短体 H=12.7 无灯 无弹 全塑 SMT LCP黑色 半金锡FU 贴麦拉 载带	
CHKD.	LYX	PJ. NO.: RJ.02.12-11-A002	
DR.	TSP	SIZE: A4 DRW NO.:	
		FINISH: SEE NOTES MAT'L.: SEE NOTES	
		SCALE: N/A REV.: A0 UNIT: mm PAGE: 2/2	