

REV.	ECN NO	CONTENT	DATE	ENGINEER
A0		Initial release	/	TSP

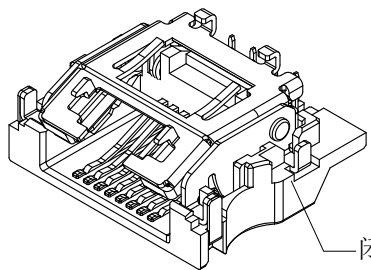

闭合状态

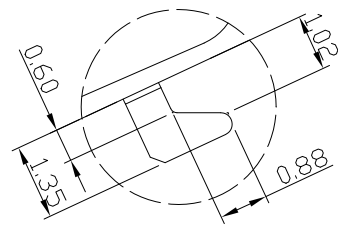
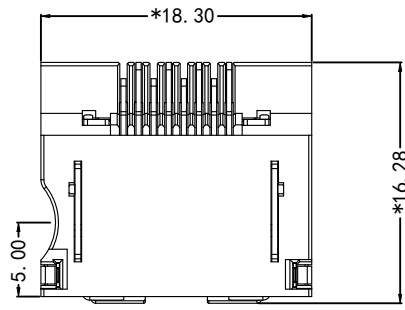

Dr tail "A" Scale 4:1

**MATERIAL:**  
HOUSING: LCP, UL94V-0, BLACK.  
TERMINAL: PHOSPHOR BRONZE T=0.35MM,  
G/FU" GOLD PLATING ON CONTACT AREA.  
SHIELD: C2680, T=0.20MM, 20~50U" MIN NICKEL PLATING ON ALL AREA.

**MACHANICAL:**  
DURABILITY: 750 CYCLES MIN, 12.5MM/MINUTE.  
INSERTION FORCE: 2.2KG.F MAX.  
RETENTION STRENGTH : 7.7KG.F BETWEEN JACK AND PLUG.  
OPERATING TEMPERATURE: -40℃~+85℃.  
STORAGE TEMPERATURE: -40℃~+85℃.  
ALL CRITICAL DIMENSIONS WITH "\*"

**ELECTRICAL:**  
VOLTAGE: 125 VOLTS AC.  
CURRENT RATING : 1.5AMP.  
DIELECTRIC STRENGTH: 1000 VAC RMS 50HZ OR 60HZ, 1 MIN.  
INSULATION RESISTANCE: 500 MEGA OHMS MIN. INITIAL AFTER 500V DC FOR 1 MINUTE.  
CONTACT RESISTANCE: SINGLE TERMINAL 30 MILLIOHMS MAX. INITIAL 50 MILLIOHMS MAX. AFTER DURABILITY TEST.

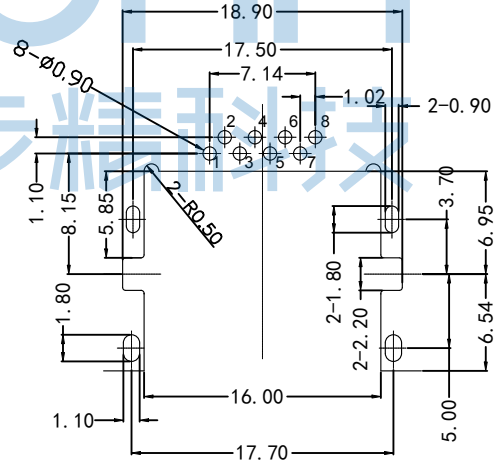
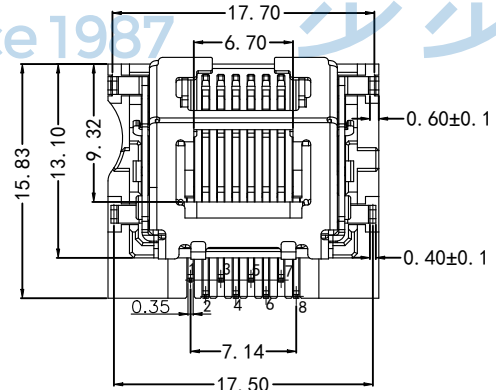
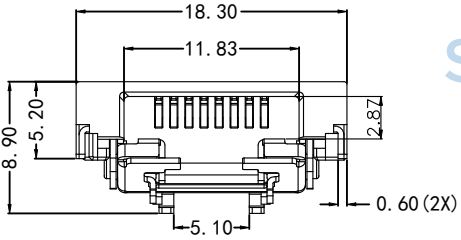
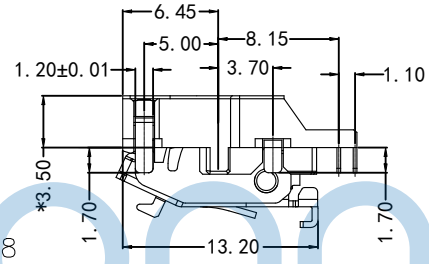
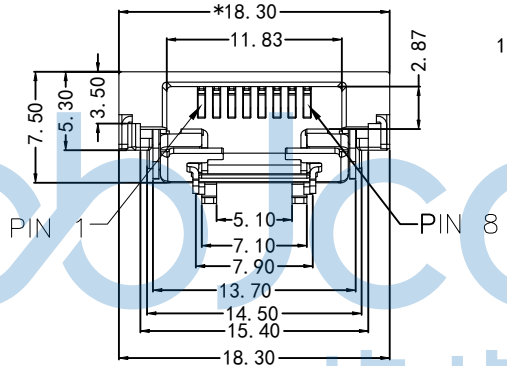
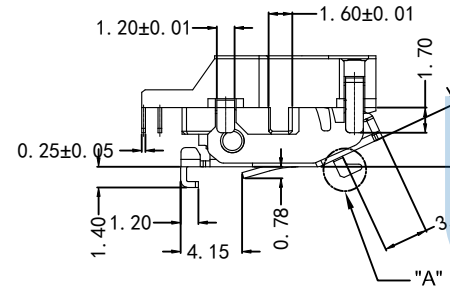

RECOMMENDED PCB LAYOUT VIEWED FROM COMPONENT SIDE

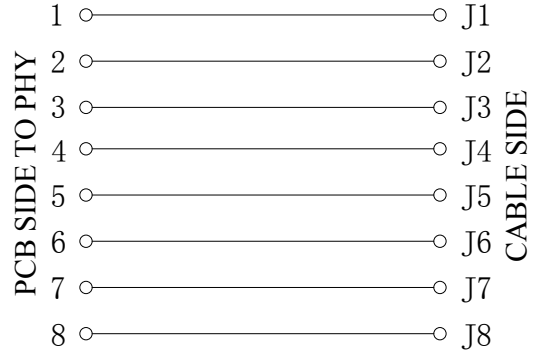

THIS DOCUMENT IS THE SOLE PROPERTY OF BBJconn Technology Co., Ltd. Corporation AND SHOULD NOT BE USED IN WHOLE OR IN PART WITHOUT PRIOR WRITTEN PERMISSION.		<b>深圳市步步精科技有限公司</b>	
.X: ±0.38 .XX: ±0.25 .XXX: ±0.13		X': ±3' .X': ±2' .XX': ±1'	
APPD.	JM_Zheng	NAME: 网络接口 RJ45 1x1 8P8C 沉板3.5 L=16.28 无灯 无弹 DIP	
CHKD.	LYX	PJ. NO.: RJ.03.22-11-A007	
DR.	TSP	SIZE: A4   DRW NO.:	
PDWG.NO: 0521-1		FINISH: SEE NOTES   MAT'L.: SEE NOTES	
		SCALE: N/A   REV.: A0   UNIT: mm   PAGE: 1/2	

REV.	ECN NO	CONTENT	DATE	ENGINEER
A0		Initial release	/	TSP

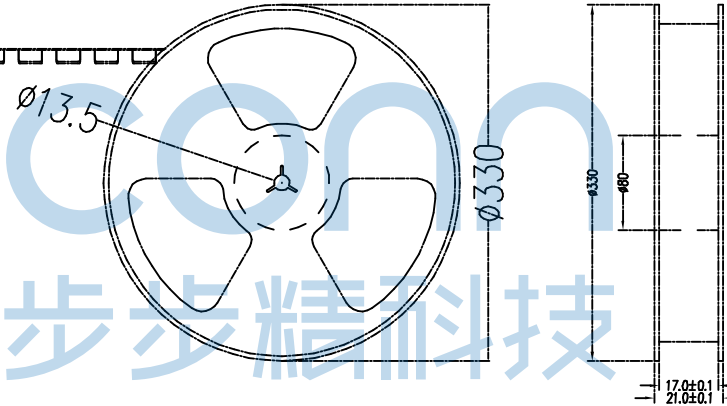
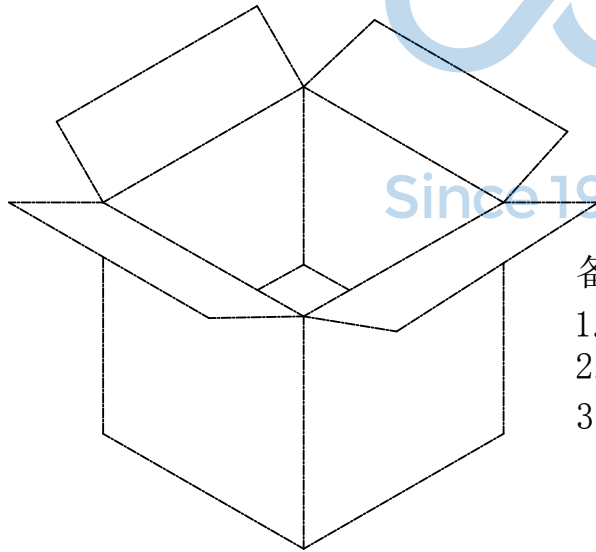
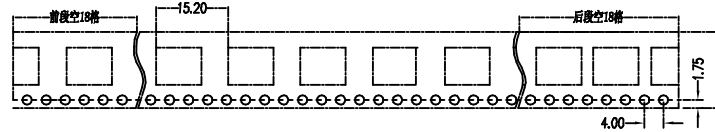
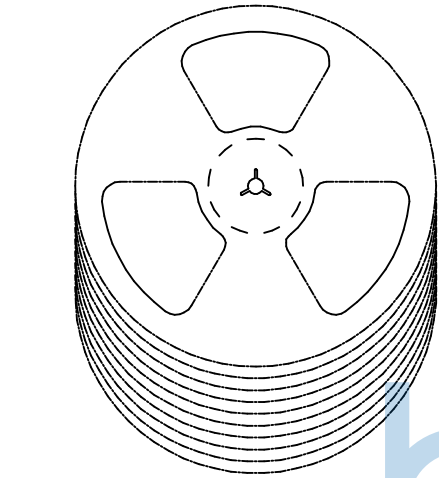

**备注:**

1. 包装数量: 300/PCS/卷, 10卷/箱。
2. 包装袋长度: 每卷前后各空10-20个空格, 中间包装。
3. 材质:  
载体: 聚丙烯 (PS),  
上带: 聚乙烯 (PET),  
卷盘: 聚苯乙烯。

纸箱规格: 345\*345\*23MM  
纸箱规格: 345\*345\*35MM

THIS DOCUMENT IS THE SOLE PROPERTY OF BBJconn Technology Co.,Ltd. Corporation AND SHOULD NOT BE USED IN WHOLE OR IN PART WITHOUT PRIOR WRITTEN PERMISSION.		<b>深圳市步步精科技有限公司</b>	
.X: ±0.38 .XX: ±0.25 .XXX: ±0.13		X': ±3" X'': ±2" X'': ±1"	
APPD.	JM_Zheng	NAME: 网络接口 RJ45 1x1 8P8C 沉板3.5 L=16.28 无灯 无弹 DIP	
CHKD.	LYX	PJ. NO.: RJ.03.22-11-A007	
DR.	TSP	SIZE: A4   DRW NO.:	
PDWG.NO:	0521-1	FINISH: SEE NOTES   MAT'L.: SEE NOTES	
		SCALE: N/A   REV.: A0   UNIT: mm   PAGE: 2/2	