

REV.	ECN NO	CONTENT	DATE	ENGINEER
A0		Initial release	/	SGF

NOTES :

- MATERIAL :
 - HOUSING:High Temperature thermoplastic,UL94V-0
 - SHELL:Stainless
 - CONTACT:Copper Alloy
- FINISH :
 - CONTACT: GOLD PLATING ON CONTACT AREA, MATTE TIN ON SOLDERTAIL AREA,NICKEL PLATING OVERALL.
 - SHELL: SOLDERABLE NICKEL PLATED OVER ALL.
- ELECTRICAL CHARACTERISTICS:
 - OPERATING VOLTAGE : 100V AC(rms)/DC.
 - CURRENT RATING : 0.5 A.
 - OPERATING TEMPERATURE: -25°C~+85°C.
 - CONTACT RESISTANCE: 100 m OHMS MAX.
 - INSULATION RESISTANCE: 1000M OHMS MIN. AT 250VDC.
 - DIELECTRIC WITHSTANDING VOLTAGE:500 VAC/1MINUTE.
- PRODUCT COMPLIANT TO ROHS AND HALOGEN FREE.

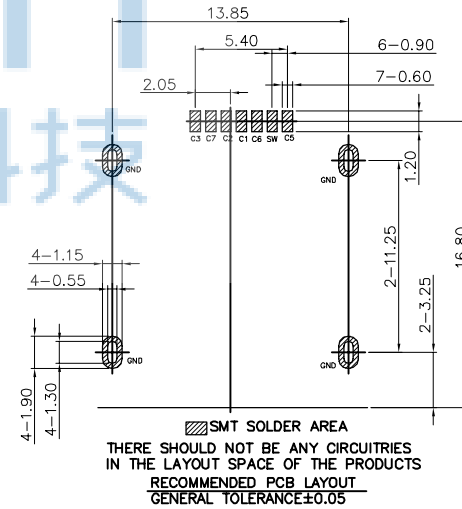
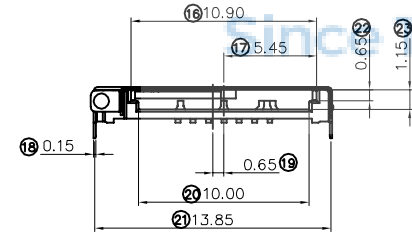
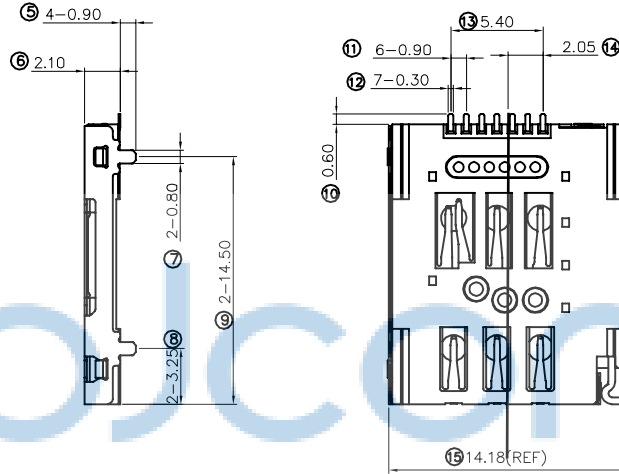
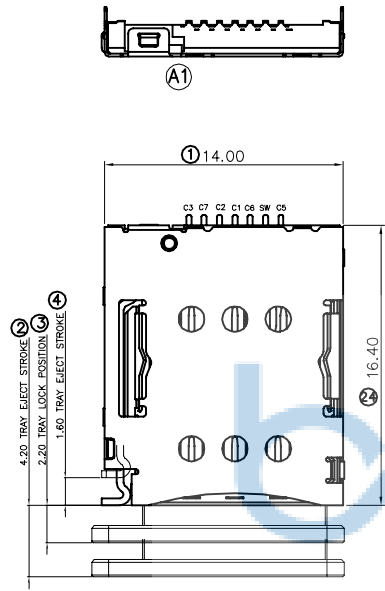

NANO SIM CARD	
C1	Vcc
C2	RST
C3	CLK
C5	GND
SW	CD/SW
C6	Vpp
C7	DATA

COMPOSITION OF DETECTION

- CARD DETECT(SW)
 C5 SW
 CARD DETECTION/SWITCH
 CARD INSTALLATION:ON
 NON CARD:OFF

THIS DOCUMENT IS THE SOLE PROPERTY OF BBJconn Technology Co.,Ltd. Corporation AND SHOULD NOT BE USED IN WHOLE OR IN PART WITHOUT PRIOR WRITTEN PERMISSION.		深圳市步步精科技有限公司 .X: ±0.38 .XX: ±0.25 .XXX: ±0.13 X': ±3' .X': ±2' .XX': ±1'		NAME: 卡座 NANO SIM CARD 6P+CD端子 外壳插板 无柱 SMT H=2.1 APPD. JM_Zheng CHKD. LYX DR. SGF	
PDWG.NO: 0361-1		PJ. NO.: CD.02.02-11-0003 SIZE: A4 DRW NO.: FINISH: SEE NOTES MAT'L.: SEE NOTES SCALE: N/A REV.: A0 UNIT: mm PAGE: 1/2			

REV.	ECN NO	CONTENT	DATE	ENGINEER
A0		Initial release	/	SGF

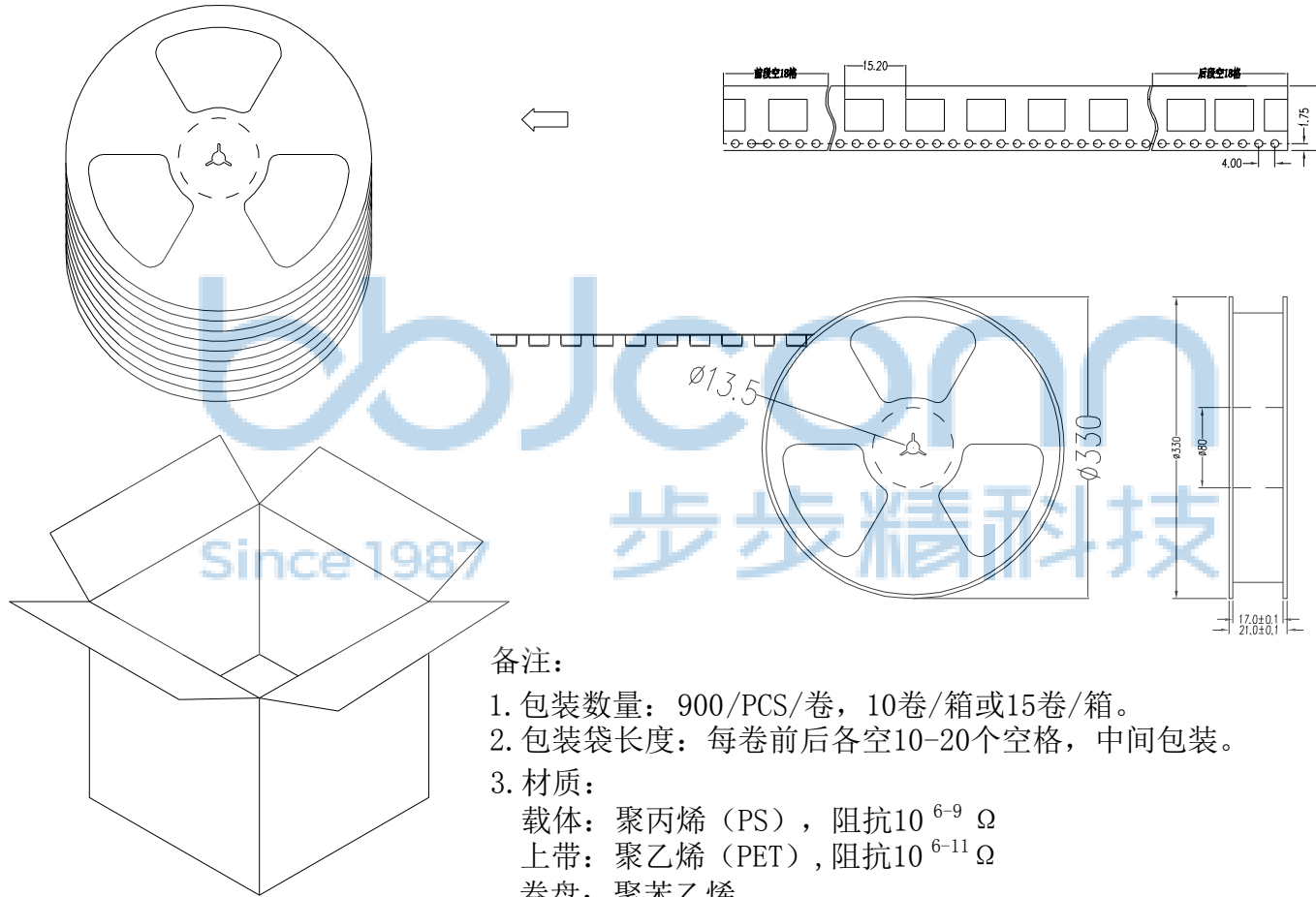

备注:

1. 包装数量: 900/PCS/卷, 10卷/箱或15卷/箱。
2. 包装袋长度: 每卷前后各空10-20个空格, 中间包装。
3. 材质:
载体: 聚丙烯 (PS), 阻抗 $10^{6-9} \Omega$
上带: 聚乙烯 (PET), 阻抗 $10^{6-11} \Omega$
卷盘: 聚苯乙烯。

纸箱规格: 345*345*23MM
纸箱规格: 345*345*35MM

THIS DOCUMENT IS THE SOLE PROPERTY OF BBJconn Technology Co.,Ltd. Corporation AND SHOULD NOT BE USED IN WHOLE OR IN PART WITHOUT PRIOR WRITTEN PERMISSION.		深圳市步步精科技有限公司 .X: ±0.38 .XX: ±0.25 .XXX: ±0.13 X': ±3" X'': ±2" XX': ±1"		NAME: 卡座 NANO SIM CARD 6P+CD端子 外壳插板 无柱 SMT H=2.1 PJ. NO.: CD.02.02-11-0003 SIZE: A4 DRW NO.: FINISH: SEE NOTES MAT'L.: SEE NOTES SCALE: N/A REV.: A0 UNIT: mm PAGE: 2/2	
APPD.	JM_Zheng	CHKD.	LYX	DR.	SGF
PDWG.NO: 0361-1					