

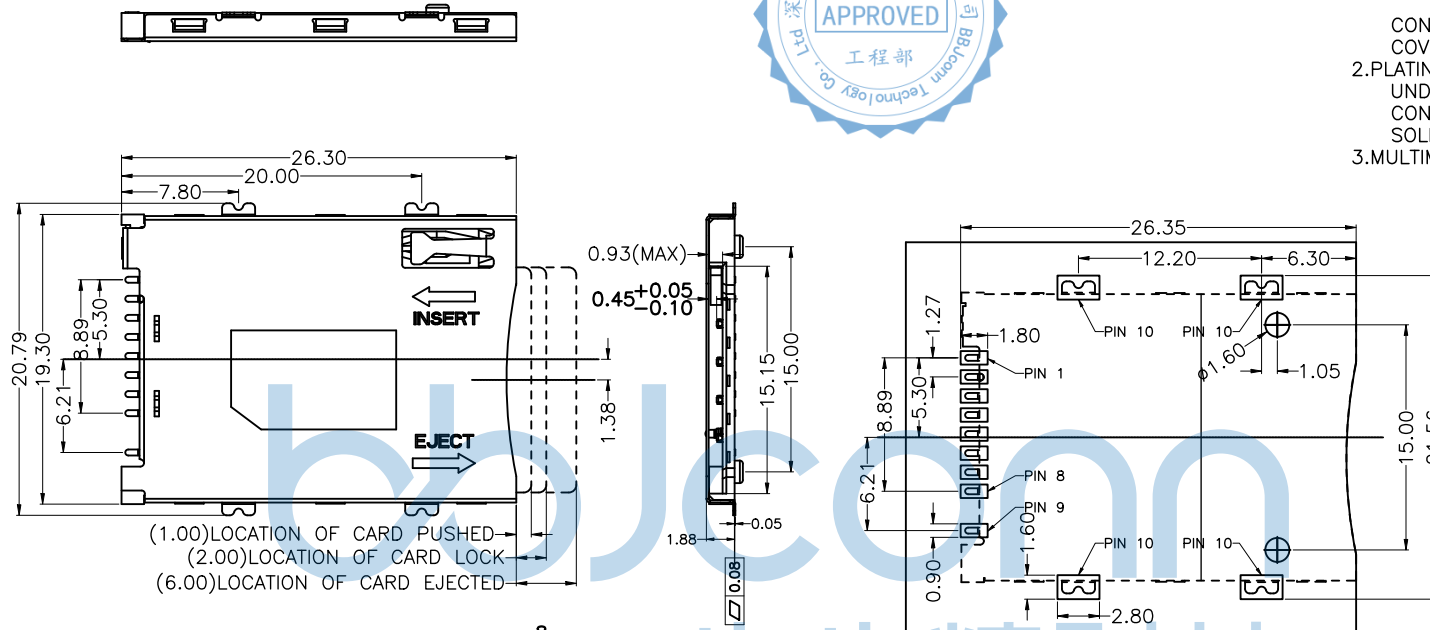

REV.	ECN NO	CONTENT	DATE	ENGINEER
A0		Initial release	/	TSP

NOTES:

- MATERIAL:
HOUSING: HIGH TEMPERATURE THERMOPLASTIC UL94V_0,COLOR:BLACK.
CONTACT: COPPER ALLOYS.
COVER: COPPER ALLOYS OR STEEL.
- PLATING:
UNDERPLATE: NICKEL.
CONTACT AREA: GOLD OVER NICKEL.
SOLDER AREA: TIN OVER NICKEL.
- MULTIMEDIA CARD COMPATIBLE



PIN NO.	NAME
PIN 1	VCC
PIN 2	GND
PIN 3	RST
PIN 4	VPP
PIN 5	CLK
PIN 6	I/O
PIN 7	DATO
PIN 8	MCMD
PIN 9	CARD DETECT Switch
PIN 10	GND

RECOMMENDED P. C. B HOLE LAYOUT
COMPONENT SIDE VIEW (TOLERANCE: +/-0.05)

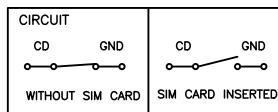
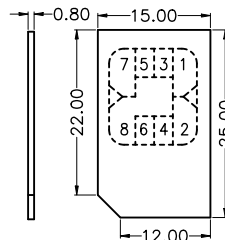
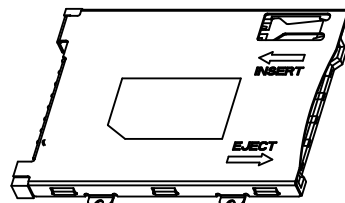
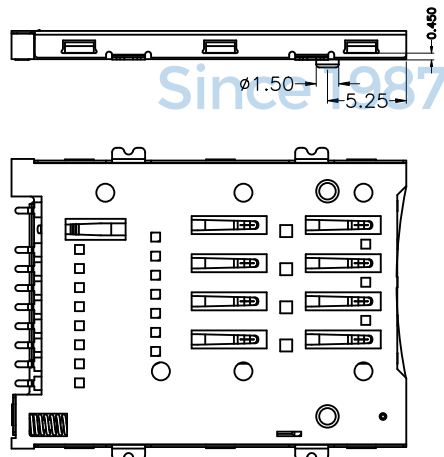

THIS DOCUMENT IS THE SOLE PROPERTY OF BBJconn Technology Co.,Ltd. Corporation AND SHOULD NOT BE USED IN WHOLE OR IN PART WITHOUT PRIOR WRITTEN PERMISSION.		深圳市步步精科技有限公司 .X: ±0.38 .X': ±3' .XX: ±0.25 .X'': ±2' .XXX: ±0.13 .XX': ±1'		NAME: 卡座 SIM PUSH 8+1 贴片 带定位柱 H=1.88	
APPD.	JM_Zheng	PJ. NO.: 142-210-090001-X8G		SIZE: A4 DRW NO.:	
CHKD.	LYX	FINISH: SEE NOTES		MAT'L.: SEE NOTES	
PDWG.NO:	0214-1	DR.	TSP	SCALE: N/A	REV.: A0 UNIT: mm PAGE: 1/2

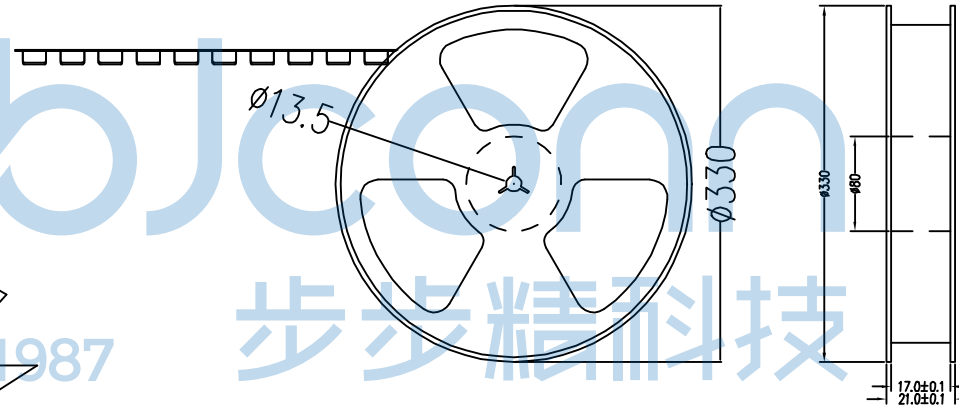
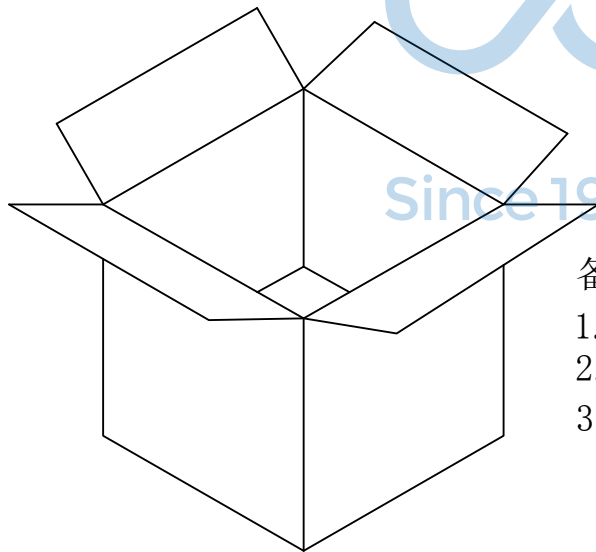
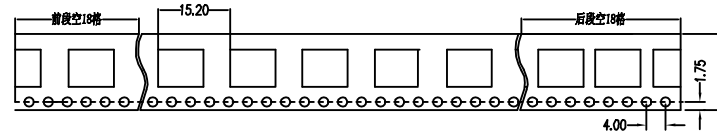
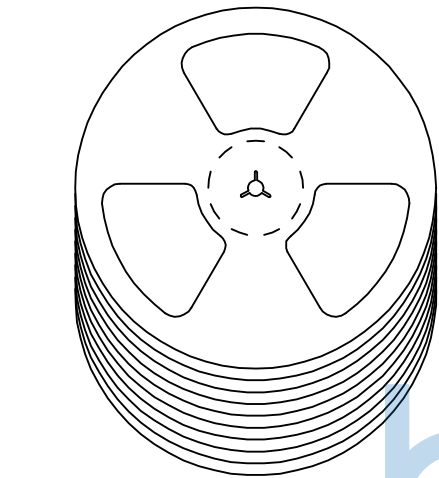

备注:

1. 包装数量: 500/PCS/卷, 10卷/箱。
2. 包装袋长度: 每卷前后各空10-20个空格, 中间包装。
3. 材质:
载体: 聚丙烯 (PS),
上带: 聚乙烯 (PET),
卷盘: 聚苯乙烯。

纸箱规格: 345*345*23MM

纸箱规格: 345*345*35MM

THIS DOCUMENT IS THE SOLE PROPERTY OF BBJconn Technology Co.,Ltd. Corporation AND SHOULD NOT BE USED IN WHOLE OR IN PART WITHOUT PRIOR WRITTEN PERMISSION.		深圳市步步精科技有限公司 .X: ±0.38 .X': ±3" .XX: ±0.25 .X'': ±2" .XXX: ±0.13 .X''': ±1"		NAME: 卡座 SIM PUSH 8+1 贴片 带定位柱 H=1.88	
APPD.	JM_Zheng	PJ. NO.: 142-210-090001-X8G SIZE: A4 DRW NO.:		FINISH: SEE NOTES MAT'L.: SEE NOTES	
CHKD.	LYX	SCALE: N/A		REV.: A0	UNIT: mm
PDWG.NO:	0214-1	DR.	TSP	PAGE: 2/2	