

REV.	ECN NO	CONTENT	DATE	ENGINEER
A0				

备注:

1. 胶芯主体材质: LCP E473
2. 端子:C5191
3. 电镀: 接触点镀金G/F
焊锡脚镀雾锡
4. ▼ 为重点管控尺寸

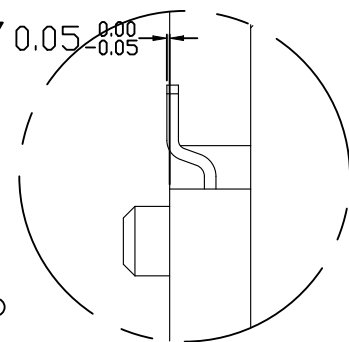
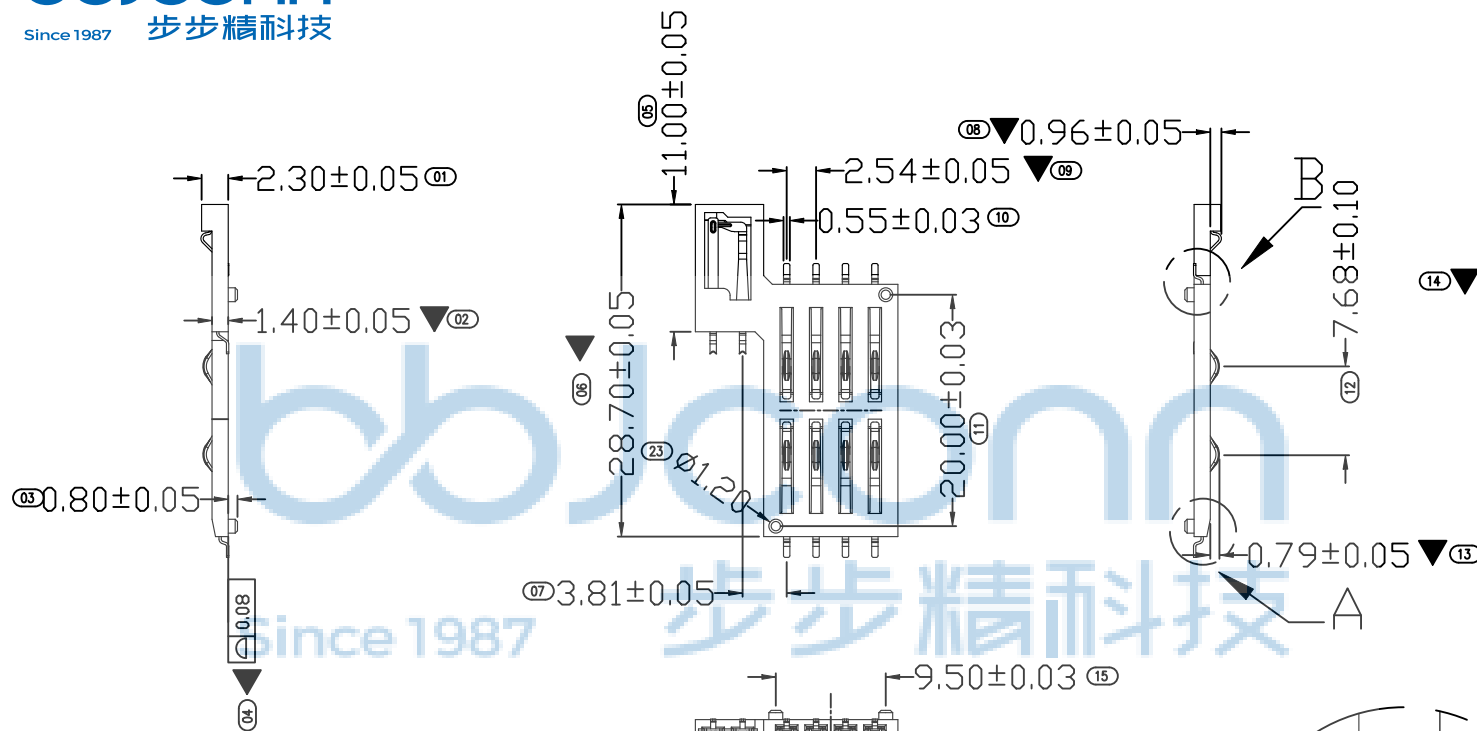

DETAIL B
SCALE 5:1

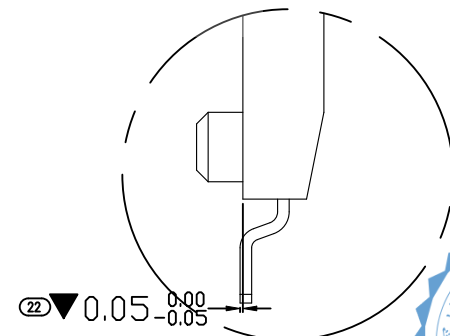
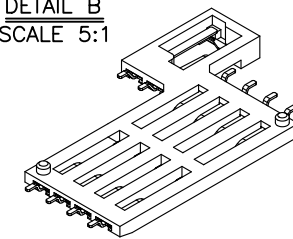

DETAIL A
SCALE 5:1

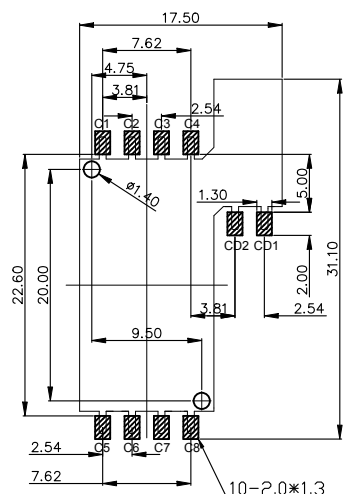

PCB Layout



PIN NO.	DESCRIPTION
C1	VCC:PWR signal and GND
C2	RST:Reset signal
C3	CLK:Clocking signal
C4	Reserved
C5	GND:PWR signal and GND
C6	VPP:Programming Voltage
C7	I/O:Serial date input/output
C8	Reserved
CD1	
CD2	

THIS DOCUMENT IS THE SOLE PROPERTY OF BBJconn Technology Co.,Ltd. Corporation AND SHOULD NOT BE USED IN WHOLE OR IN PART WITHOUT PRIOR WRITTEN PERMISSION.

PDWG.NO: 0302-1

深圳市步步精科技有限公司

NAME: 卡座 SIM 8+2P L=28.7 H=2.30 带柱 贴片 右耳 (C-102014182-00)

APPD. JM_Zheng

CHKD. LYX

DR. LHC

PJ. NO.: CD.02.02-13-0012

SIZE: A4 DRW NO.:

FINISH: SEE NOTES MAT'L.: SEE NOTES

SCALE: N/A REV.: A0 UNIT: mm PAGE: 1/1

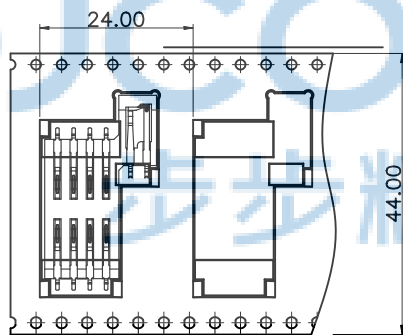
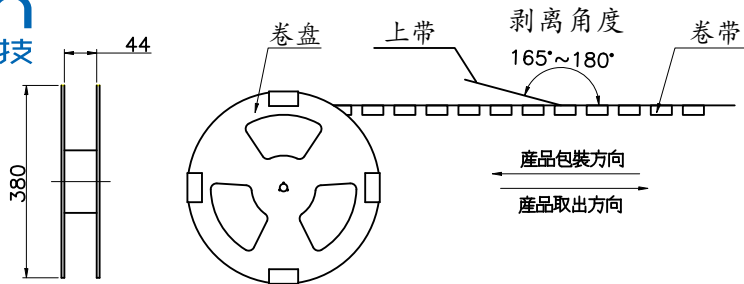

RELL盘 6 Pcs

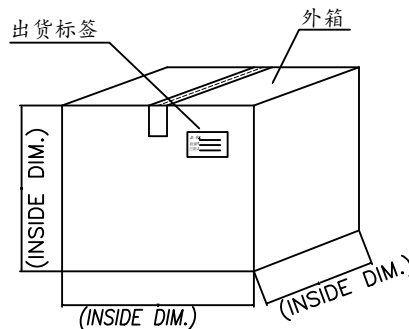
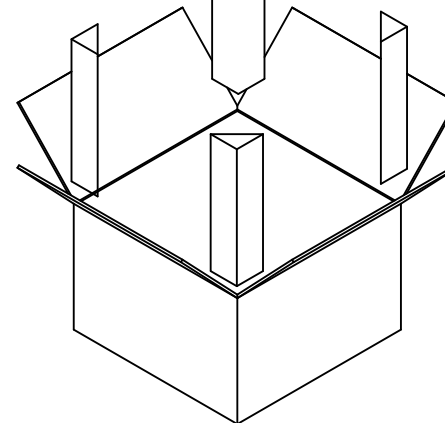
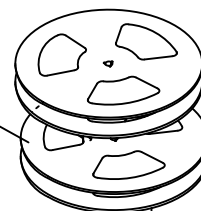
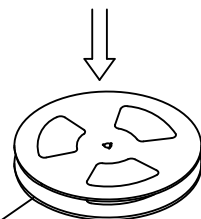
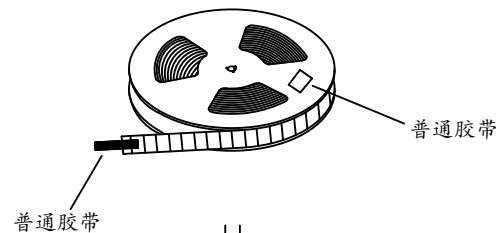
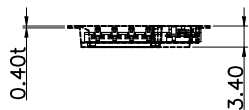

1. 包装方式:

- 1.1. 使用半自动包装机, 先将透明上带送入导轨中, 并粘贴在上面, 其中初始空槽14pcs不要放产品, 然后将产品如图所示方向依次放入卷带每个槽放1pcs. 最后需留14空槽不放产品.
- 1.2. 用胶带将卷带及上透明带压合在一起且在外, 在卷盘上贴上标签. 注明品名, 日期, 数量.
- 1.3. 依图示, 将5pcs已装好成品的卷盘装入外箱.
- 1.4. 将装好卷盘的外箱四角放入折叠板, 封箱后贴上外标签.

2. 包装数量:

- 1000PCS/卷;
- 6卷(6000pcs)/箱

THIS DOCUMENT IS THE SOLE PROPERTY OF BBJconn Technology Co.,Ltd. Corporation AND SHOULD NOT BE USED IN WHOLE OR IN PART WITHOUT PRIOR WRITTEN PERMISSION. PDWG.NO: 0302-1	深圳市步步精科技有限公司		NAME:
	.X: ±0.38 .XX: ±0.25 .XXX: ±0.13	X*: ±3" .X*: ±2" .XX*: ±1"	卡座 SIM 8+2P L=28.7 H=2.30 带柱 贴片 右耳 (C-102014182-00)
	APPD. JM_Zheng	CHKD. LYX	PJ. NO.: CD.02.02-13-0012 SIZE: A4 DRW NO.:
	DR. LHC	FINISH: SEE NOTES SCALE: N/A	MAT'L.: SEE NOTES REV.: AO UNIT: mm PAGE: 1/1