

REV.	ECN NO	CONTENT	DATE	ENGINEER
A0		Initial release	/	SGF

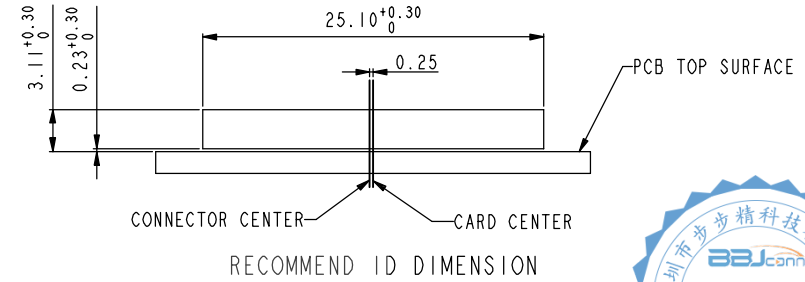

NOTES:

- (1) MATERIAL:
 - 1-1. PLASTIC: LCP, THERMOPLASTIC UL 94V-0 COLOR: BLACK
 - 1-2. CONTACT: COPPEER ALLOY.
 - 1-3. SELL: STAINLESS STELL.
- (2) PATING:
 - 2-1. CONTACT:CONTACT AREA AU 30U" MIN.
SOLDER TAIL AREA: PLATING AU 1U" MIN, OVER NI .
 - 2-2. SHELL:SOLDERABILITY AU 1U" MIN PLATING OVER ALL.
- (3) CONTACT AND TAIL COPLANARITY TO BE 0.10MM MAX.
- (4) RECOMMENDING A METAL MORE THAN 0.15mm THICK.
- (5) insertion and extraction force :0.7~3.0Kg.
- (6) Mylar has no backing at the opening.

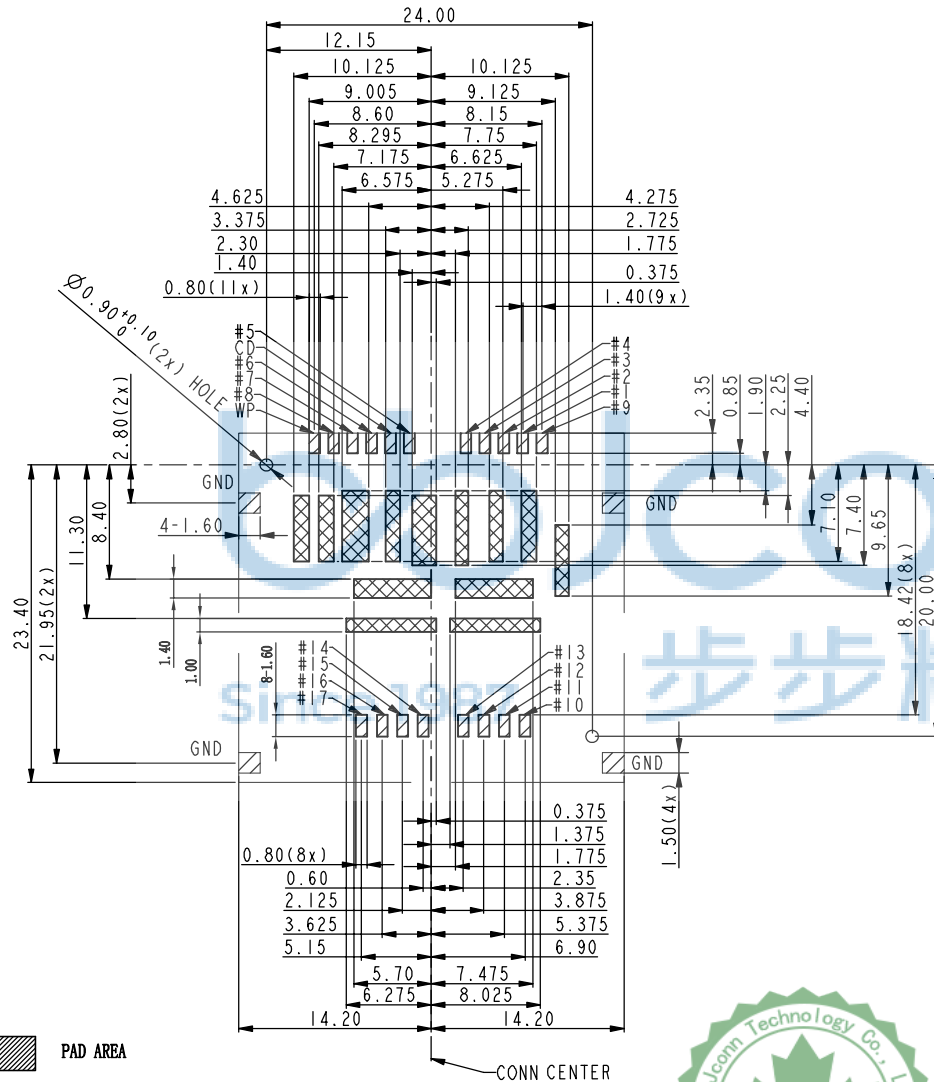
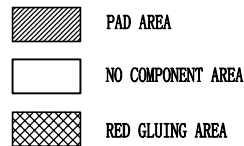

RECOMMENDED P.C.B LAYOUT
TOP VIEW (TOLERANCE±/±0.05)

THIS DOCUMENT IS THE SOLE PROPERTY OF BBJconn Technology Co.,Ltd. Corporation AND SHOULD NOT BE USED IN WHOLE OR IN PART WITHOUT PRIOR WRITTEN PERMISSION.		深圳市步步精科技有限公司 NAME: 卡座 SD4.0 No Push 11P H=2.95 四脚贴片 带柱 PJ. NO.: 142-319-110001-V8G SIZE: A4 DRW NO.: FINISH: SEE NOTES MAT'L.: SEE NOTES SCALE: N/A REV.: A0 UNIT: mm PAGE: 2/3	
PDWG.NO: 0302-1	DR. SGF	APPD. JM_Zheng	CHKD. LYX

客户拉出方向

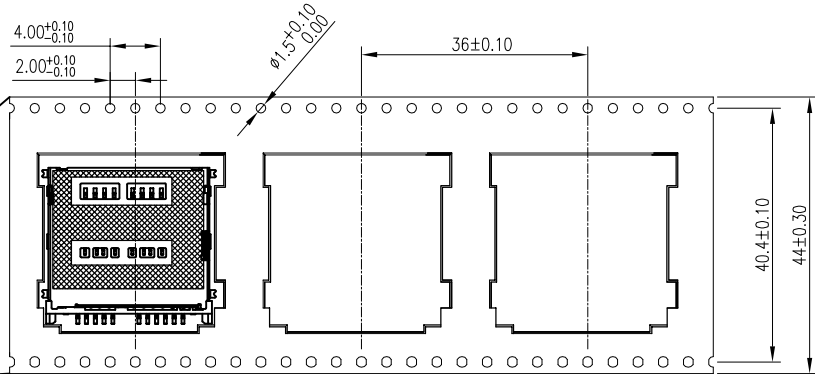

客户拉出方向

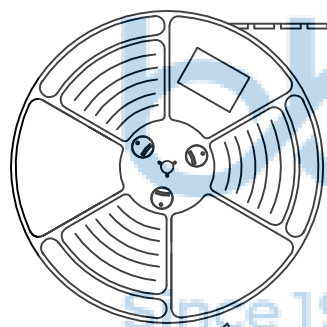
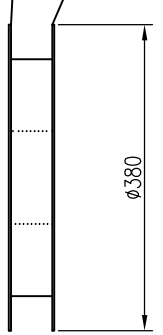

NOTES

1. 每卷包装数量:450PCS/每卷
2. 卷带包装方式:

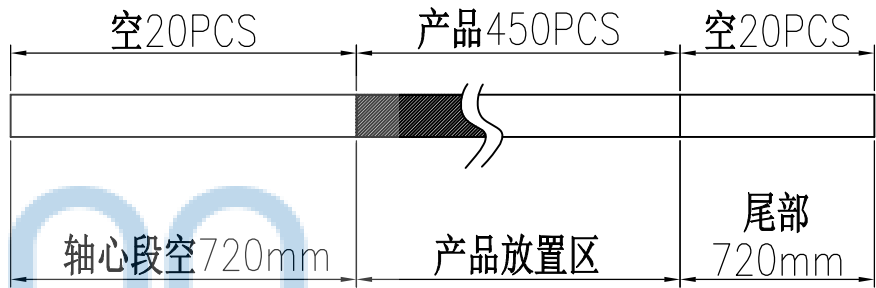

3. 每箱包装数量:3600PCS/箱

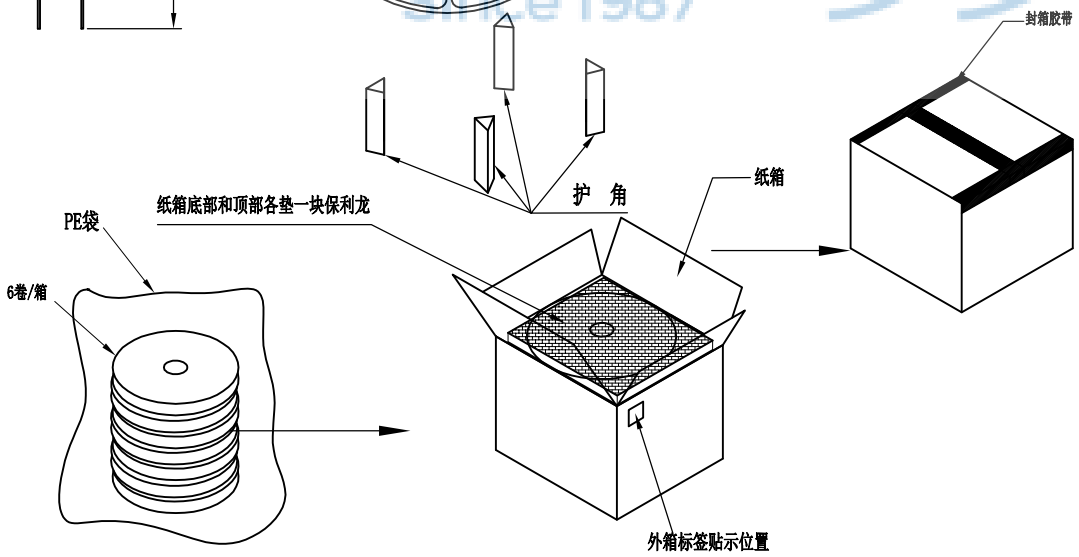

THIS DOCUMENT IS THE SOLE PROPERTY OF BBJconn Technology Co.,Ltd.		深圳市步步精科技有限公司	
PRIOR WRITTEN PERMISSION. NOT BE USED IN WHOLE OR IN PART WITHOUT		NAME: 卡座 SD4.0 No Push 11P H=2.95 四脚贴片 带柱	
APPD.	JM_Zheng	PJ. NO.: 142-319-110001-V8G	
CHKD.	LYX	SIZE: A4 DRW NO.:	
PDWG.NO:	0302-1	FINISH: SEE NOTES MAT'L.: SEE NOTES	
DR.	SGF	SCALE: N/A REV.: A0 UNIT: mm PAGE: 3/3	