

REV.	ECN NO.	CONTENT	DATE	ENGINEER
A0		Initial release	/	SGF

NOTES:

- MATERIAL:
HOUSING: High Temperature Thermoplastic
Terminal: Copper Alloy
Shell: Stainless Steel
- PLATING:
Terminal: 50u" Ni UNDERPLATED OVERALL
G/F PLATED ON CONTACT AREA AND SOLDER AREA
Shell: 50u" Ni UNDERPLATED OVERALL
G/F PLATED ON CONTACT AREA AND SOLDER AREA
- TECHNICAL SPECIALITY:
RATED VOLTAGE: 30V AC MAX.
CURRENT RATING: 0.5A MAX.
INSULATION RESISTANCE: 1000Ω MIN
CONTACT RESISTANCE: 50mΩ MAX
WITHSTANDING VOLTAGE: 500V AC FOR 1 MINUTES
OPERATING TEMPERATURE: -40°C~+85°C Humidity 80% R.H MAX

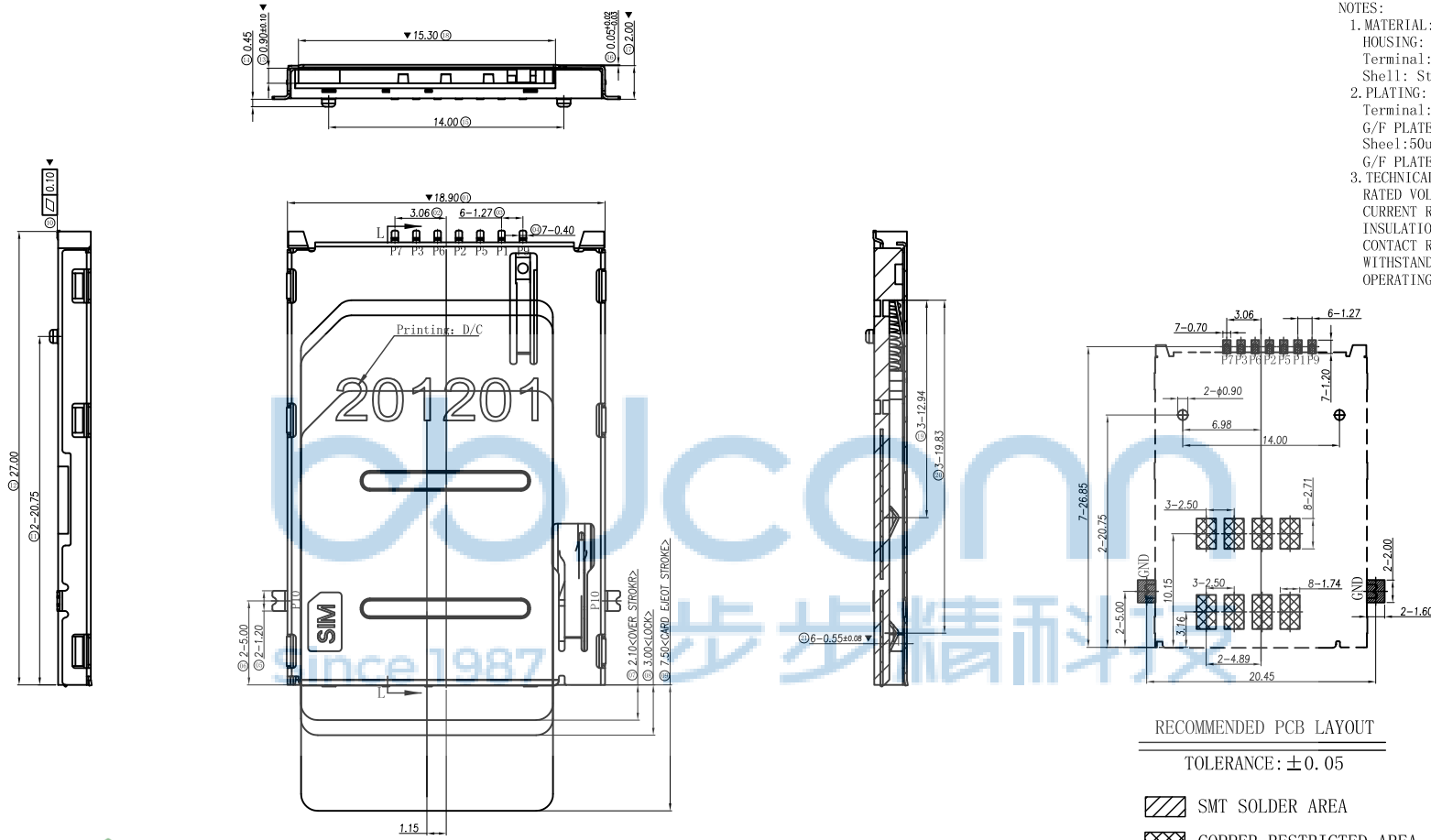

RECOMMENDED PCB LAYOUT

TOLERANCE: ±0.05

- SMT SOLDER AREA
- COPPER RESTRICTED AREA
 1. TOUCH AREA OF CONTACT TIPS NO ELECTRICAL FUNCTION
 2. NO FIRST PCB_LAYOUT CIRCUITS IN THE AREA

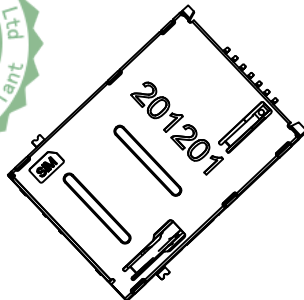

PIIN/NO	ASSIGNMENT
P1	VCC
P2	RST
P3	CLK
P5	GND
P6	VPP
P7	I/O
P9	Detect Switch
P10	GND

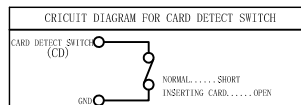

THIS DOCUMENT IS THE SOLE PROPERTY OF BBJconn Technology Co.,Ltd.
CORPORATION AND SHOULD NOT BE USED IN WHOLE OR IN PART WITHOUT PRIOR WRITTEN PERMISSION.

PDWG.NO: 0302-1

APPD. JM_Zheng
CHKD. LYX
DR. SGF

NAME: 卡座 SM015-100 SIM 6PIN Push-Push H=2.0 贴片 带柱
PJ. NO.: 142-220-060001-V8G
SIZE: A4 DRW NO.:

FINISH: SEE NOTES MAT'L.: SEE NOTES
SCALE: N/A REV.: A0 UNIT: mm PAGE: 1/2

深圳市步步精科技有限公司

REV.	ECN NO.	CONTENT	DATE	ENGINEER
A0		Initial release	/	SGF

Direction of use →

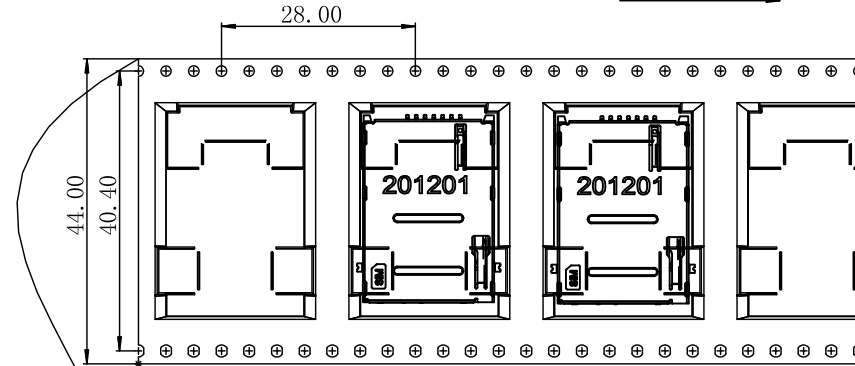

NOTES:

- 1、Packing quantity per plate: 600PCS/Plate
- 2、Loading and packing method

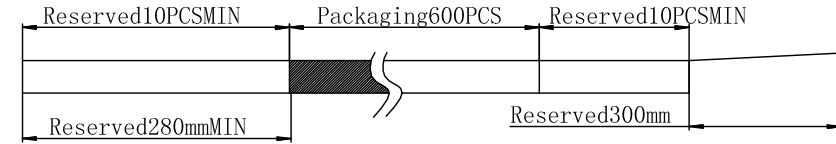

3、Total packaging: 3600PCS/Box

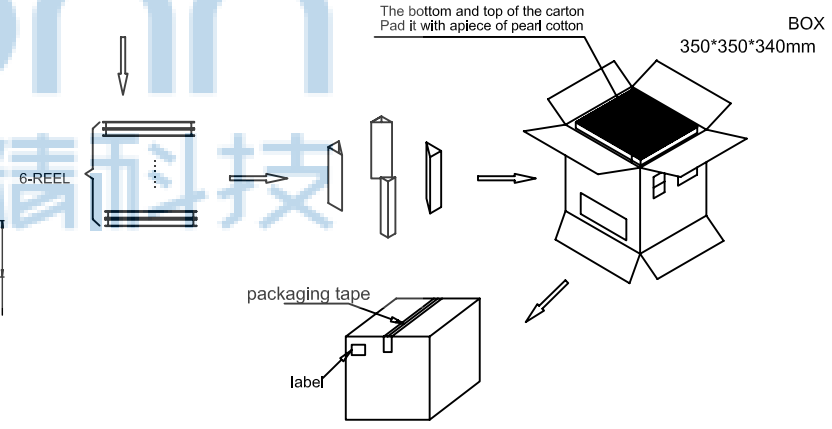
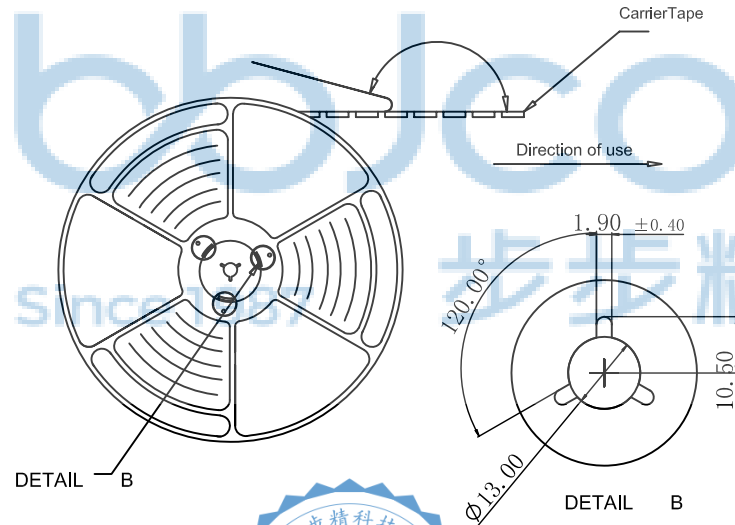
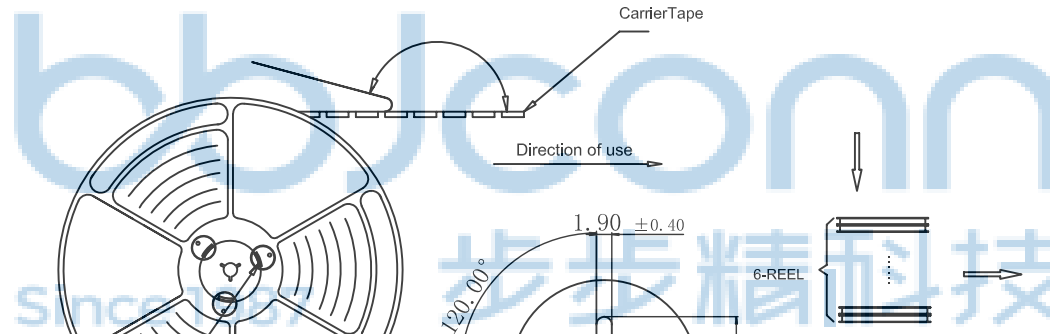

DETAIL B

DETAIL B



Description	Quantity
Carrierband (Black, PETW=44PH=28,T=0.3)	104.16m
Box (K=K,T=7.0,350*350*340)	1PCS
PE Bag (T=0.08mm, 730*760*730)	1PCS
Self-adhesive (W=37.50)	105.96m
Beam (K=K, T=7.0,95*95*290)	4PCS
PearlWool (340*340*18)	2PCS
REEL (BLUE, 13Inches*44mm, φ330)	6PCS
2.0H 6PIN Push-Push SIM卡座	3600PCS

THIS DOCUMENT IS THE SOLE PROPERTY OF BBJconn Technology Co.,Ltd. Corporation AND SHOULD NOT BE USED IN WHOLE OR IN PART WITHOUT PRIOR WRITTEN PERMISSION.		深圳市步步精科技有限公司 .X: ±0.38 .XX: ±0.25 .XXX: ±0.13 X': ±3" X'': ±2" XX': ±1"		NAME: 卡座 SIM015-100 SIM 6PIN Push-Push H=2.0 贴片 带柱 PJ. NO.: 142-220-060001-V8G SIZE: A4 DRW NO.: FINISH: SEE NOTES MAT'L.: SEE NOTES SCALE: N/A REV.: A0 UNIT: mm PAGE: 2/2	
APPD.	JM_Zheng	CHKD.	LYX	DR.	SGF
PDWG.NO:	0302-1				