

REV.	ECN NO	CONTENT	DATE	ENGINEER
A0		Initial release	/	SGF

Technical requirements:

- Rating :
CQC : 16(6) A 125/250V~
VDE,ENEC,KC: 16(6) A 250V~
UL , cUL : 20(8) A 125/250V~
1HP 250V~
3/4HP 125V~
- Operating force: 800±400gf
- Contact resistance: ≤50mΩ
- Electrical life: ≥10000 cycles
- Withstand Voltage :Between all terminals:
1500VAC (50-60Hz)1min
Terminals to Button:
3000V AC (50-60Hz)1min
Leakage Current : 20mA
- Insulation Resistance : ≥100MΩ 500V DC
- Environmental temperature: : -25~+125°C

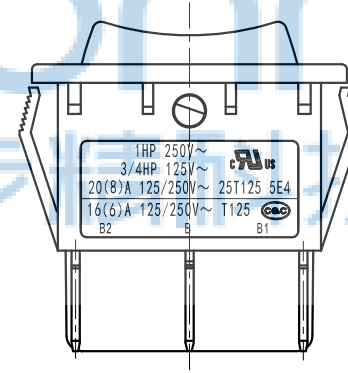
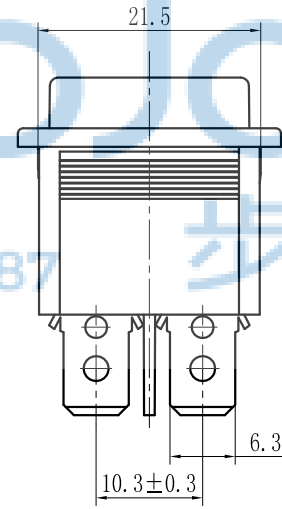
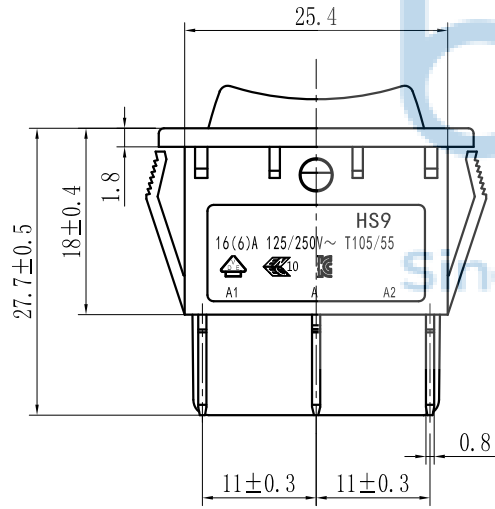
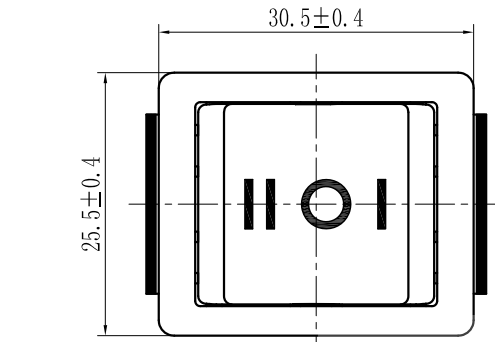
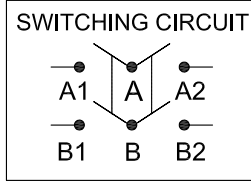

PANEL CUT-OUT

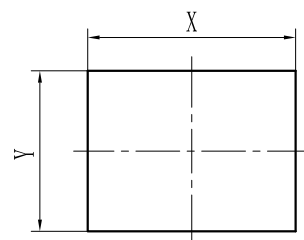

PANEL THICKNESS	DIM.X	DIM.Y
0.75~1.25	27.5~27.6	21.6
1.25~2.0	27.7~27.9	21.6
2.0~3.0	28.0~28.2	21.6



THIS DOCUMENT IS THE SOLE PROPERTY OF BBJconn Technology Co.,Ltd. Corporation AND SHOULD NOT BE USED IN WHOLE OR IN PART WITHOUT PRIOR WRITTEN PERMISSION.		深圳市步步精科技有限公司 .X: ±0.38 .XX: ±0.25 .XXX: ±0.13 X': ±3" .X': ±2" .XX': ±1"		NAME: 船型开关 HS9-E1-05Q200-BB07 六脚插 APPD. JM_Zheng CHKD. LYX DR. SGF	PJ. NO.: RS.14.11-52-2001 SIZE: A4 DRW NO.: FINISH: SEE NOTES MAT'L.: SEE NOTES SCALE: N/A REV.: A0 UNIT: mm PAGE: 1/2
PDWG.NO: 0004-1					

REV.	ECN NO	CONTENT	DATE	ENGINEER
A0		Initial release	/	SGF

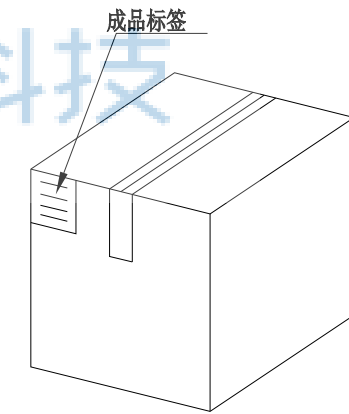
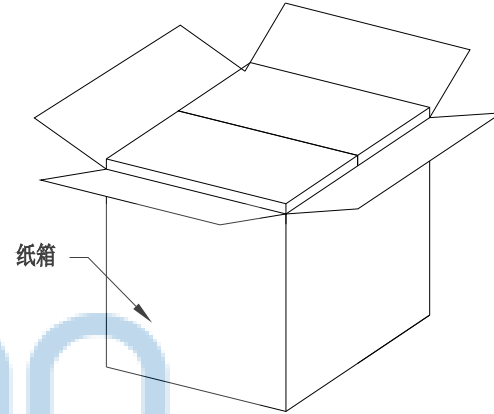
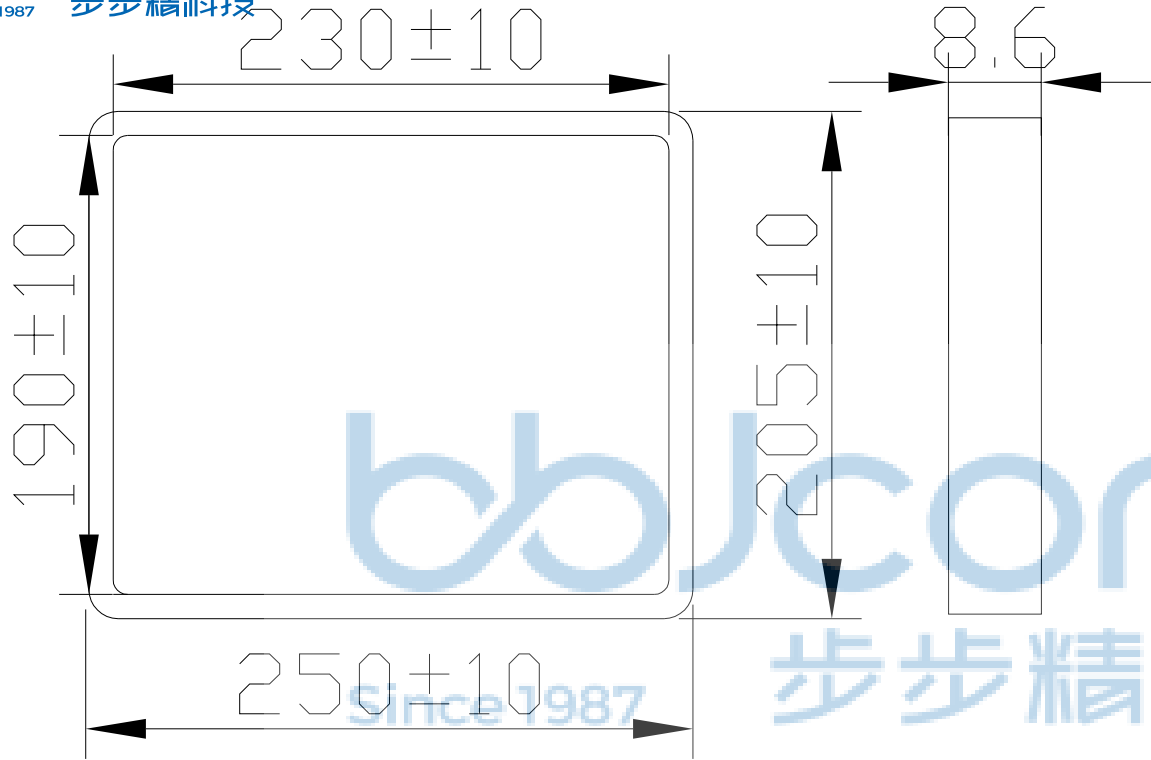

1. 包装要求:
- 1.1 每盒吸塑盒包装 50 pcs;
 - 1.2 每20盘放一箱, 共计 100 PCS;
 - 1.3 纸箱外贴上标签



纸箱规格: 350*210*290

THIS DOCUMENT IS THE SOLE PROPERTY OF BBJconn Technology Co.,Ltd. Corporation AND SHOULD NOT BE USED IN WHOLE OR IN PART WITHOUT PRIOR WRITTEN PERMISSION.		深圳市步步精科技有限公司	
PDWG.NO: 0004-1		.X: ±0.38 .XX: ±0.25 .XXX: ±0.13	X': ±3" .X': ±2" .XX': ±1"
APPD.	JM_Zheng	NAME: 船型开关 HS9-E1-05Q200-BB07 六脚插	
CHKD.	LYX	PJ. NO.: RS.14.11-52-2001	
DR.	SGF	SIZE: A4 DRW NO.:	
		FINISH: SEE NOTES MAT'L.: SEE NOTES	
		SCALE: N/A	REV.: A0 UNIT: mm PAGE: 2/2