

REV.	ECN NO.	CONTENT	DATE	ENGINEER
A0		Initial release	/	TSP

Technical requirements:

- Rating :
CQC: 6(4) A 125/250V~
VDE, ENEC: 6(4) A 250V~
UL , cUL : 10(6) A 125/250V~
- Operating force: 650±350gf
- Contact resistance: ≤50mΩ
- Electrical life: ≥10000 cycles
- Withstand Voltage :Between all terminals:
1500VAC (50-60Hz) 5s
Terminals to Button:
3000V AC (50-60Hz) 5s
Leakage Current : 5mA
- Insulation Resistance : ≥100MΩ 500V DC
- Environmental temperature: : -25~+125°C

PANEL THICKNESS	DIM.X	DIM.Y
0.75~1.25	19.0~19.2	6.95
1.25~2.0	19.3~19.5	6.95
2.0~3.0	19.6~19.8	6.95

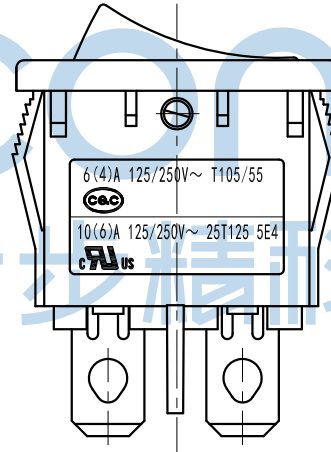
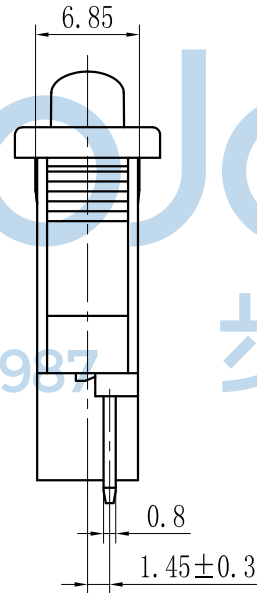
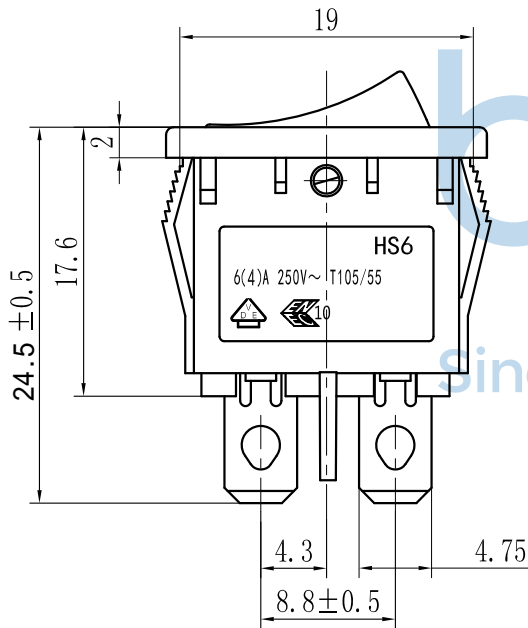
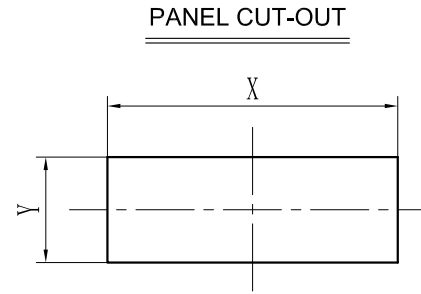
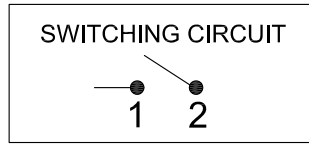
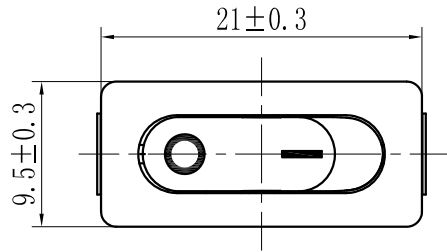

THIS DOCUMENT IS THE SOLE PROPERTY OF BBJconn Technology Co.,Ltd. Corporation AND SHOULD NOT BE USED IN WHOLE OR IN PART WITHOUT PRIOR WRITTEN PERMISSION.		深圳市步步精科技有限公司 .X: ±0.38 .X': ±3" .XX: ±0.25 .X': ±2" .XXX: ±0.13 .XX': ±1"		NAME: 船型开关 HS6-F2-6-01Q100-BB03 两脚插 P.J. NO.: RS.17.11-22-2003 SIZE: A4 DRW NO.: FINISH: SEE NOTES MAT'L.: SEE NOTES SCALE: N/A REV.: A0 UNIT: mm PAGE: 1/2	
APPD.	JM_Zheng	CHKD.	LYX	DR.	TSP
PDWG.NO: 0004-1					

REV.	ECN NO	CONTENT	DATE	ENGINEER
A0		Initial release	/	TSP

PE袋规格: 260*185

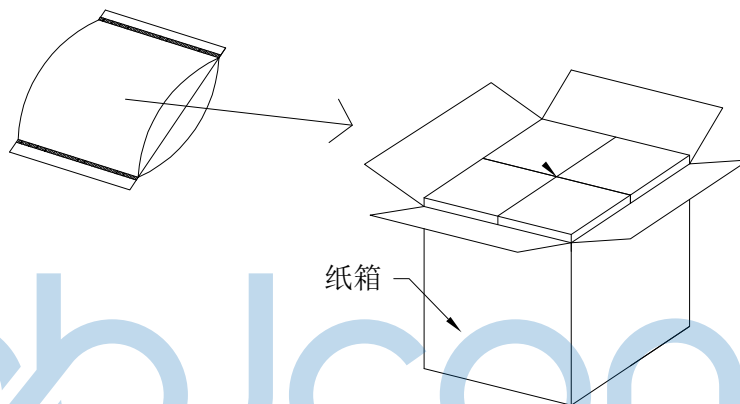

成品标签

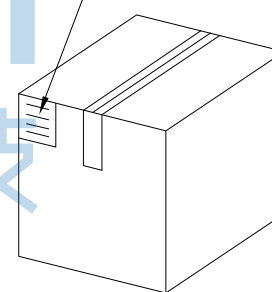

1. 包装要求:

- 1.1 每个PE袋包装400pcs;
- 1.2 每1袋放一小纸盒;
- 1.3 每20个小纸盒放一个纸箱, 共计8000pcs;
- 1.4 纸箱外贴上标签



THIS DOCUMENT IS THE SOLE PROPERTY OF BBJconn Technology Co.,Ltd.		深圳市步步精科技有限公司	
Corporation AND SHOULD NOT BE USED IN WHOLE OR IN PART WITHOUT PRIOR WRITTEN PERMISSION.		NAME: 船型开关 HS6-F2-6-01Q100-BB03 两脚插	
.X: ±0.38 .XX: ±0.25 .XXX: ±0.13		X': ±3" .X': ±2" .XX': ±1"	
APPD.	JM_Zheng	PJ. NO.: RS.17.11-22-2003	
CHKD.	LYX	SIZE: A4 DRW NO.:	
PDWG.NO:	0004-1	FINISH: SEE NOTES MAT'L.: SEE NOTES	
DR.	TSP	SCALE: N/A REV.: A0 UNIT: mm PAGE: 2/2	