

REV.	ECN NO	CONTENT	DATE	ENGINEER
A0		Initial release	/	SGF

Technical requirements:

- Rating : CQC: 16A 125/250V~
12(4) A 125/250V~
VDE,ENEC,KC: 12(4) A 250V~
UL , cUL : 16 A 125V~
12(6) A 125/250V~
1/2HP 125/250V~
- Operating force: 650±350gf
- Contact resistance: ≤50mΩ
- Electrical life: ≥10000 cycles
- Withstand Voltage :Between all terminals:
1500VAC (50-60Hz) 5s
Terminals to Button:
3000V AC (50-60Hz) 5s
Leakage Current : 5mA
- Insulation Resistance : ≥100MΩ 500V DC
- Environmental temperature: : -25~+125℃

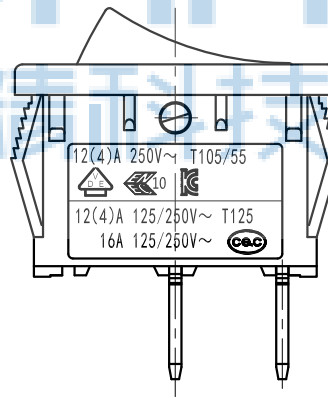
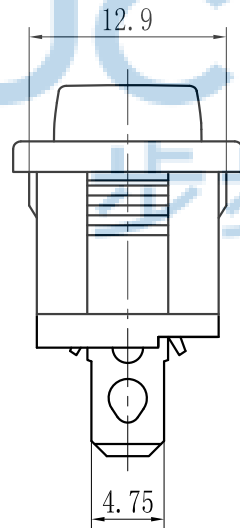
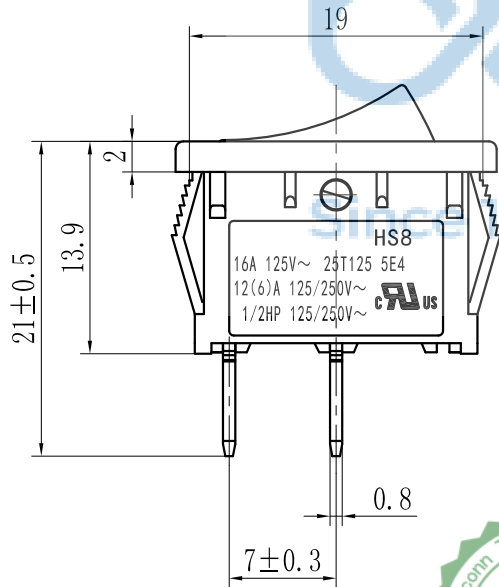
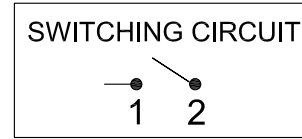
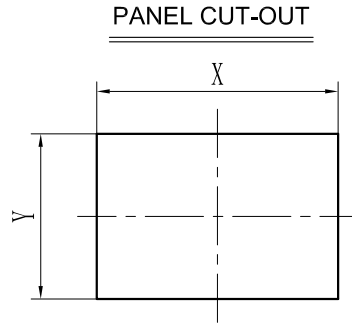
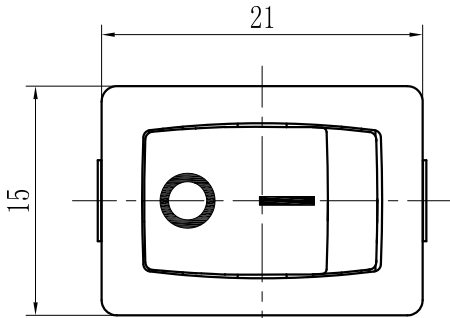

PANEL THICKNESS	DIM.X	DIM.Y
0.75~1.25	19.0~19.2	13.0
1.25~2.0	19.3~19.5	13.0
2.0~3.0	19.6~19.8	13.0



THIS DOCUMENT IS THE SOLE PROPERTY OF BBJconn Technology Co.,Ltd. Corporation AND SHOULD NOT BE USED IN WHOLE OR IN PART WITHOUT PRIOR WRITTEN PERMISSION.		深圳市步步精科技有限公司	
PDWG.NO: 0004-1		APPD. JM_Zheng	NAME: 船型开关 HS8-F1-8-01Q100-BB03 两脚直插
DR. SGF		CHKD. LYX	PJ. NO.: RS.17.11-22-2007
		SIZE: A4 DRW NO.:	
		FINISH: SEE NOTES MAT'L.: SEE NOTES	
		SCALE: N/A REV.: A0 UNIT: mm PAGE: 1/2	

REV.	ECN NO	CONTENT	DATE	ENGINEER
A0		Initial release	/	SGF

PE袋规格:***X*** (以实际出货为准)

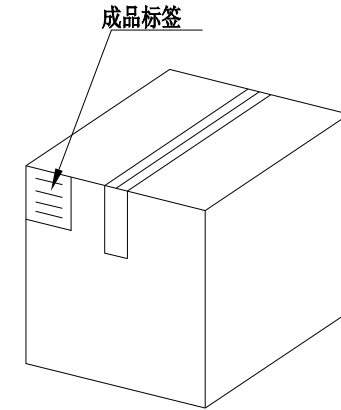
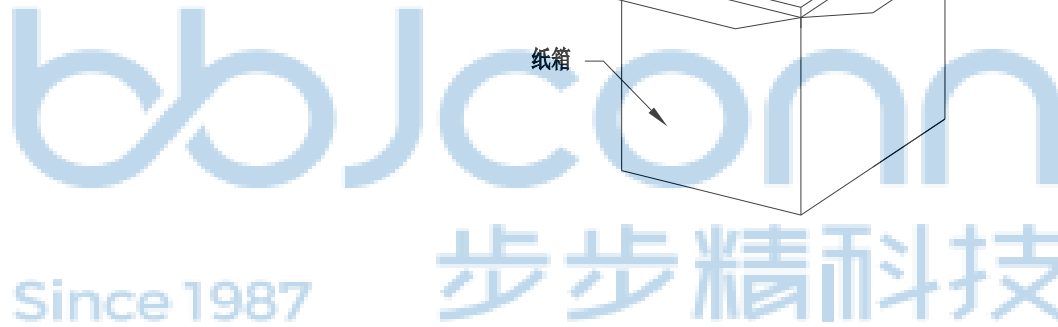
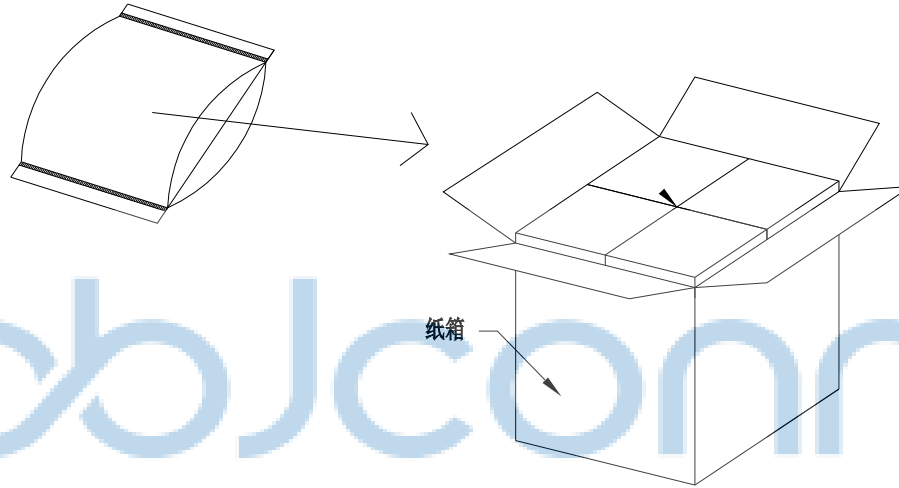

1. 包装要求:

- 1.1 每PE袋包装300 pcs;
- 1.2 每1袋放一小纸盒;
- 1.3 每20个小纸盒放一个纸箱, 共计6000PCS
- 1.4 纸箱外贴上标签



THIS DOCUMENT IS THE SOLE PROPERTY OF BBJconn Technology Co.,Ltd. Corporation AND SHOULD NOT BE USED IN WHOLE OR IN PART WITHOUT PRIOR WRITTEN PERMISSION.		深圳市步步精科技有限公司 .X: ±0.38 X': ±3' NAME: .XX: ±0.25 X'': ±2' 船型开关 HS8-F1-8-01Q100-BB03 两脚直插 .XXX: ±0.13 XX': ±1'	
APPD.	JM_Zheng	PJ. NO.: RS.17.11-22-2007 SIZE: A4 DRW NO.:	
CHKD.	LYX		
PDWG.NO:	0004-1	DR.	SGF
		FINISH: SEE NOTES	MAT'L.: SEE NOTES
		SCALE: N/A	REV.: A0 UNIT: mm PAGE: 2/2