

REV.	ECN NO	CONTENT	DATE	ENGINEER
A0		Initial release	/	LYL

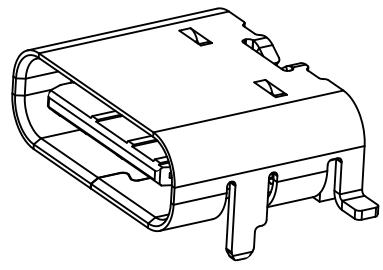

SPECIFICATION:

- ELECTRICAL CHARACTERISTICS:**
 - CURRENT RATING: 3A
 - TEMPERATURE RANGE: -40 °C ~ 85 °C
 - CONTACT RESISTANCE: 30 MILLIONHM MAX.
 - DIELECTRIC WITHSTANDING VOLTAGE: 100 VAC r.m.s
 - INSULATION RESISTANCE: 100 MEGOHMS MIN.
- MECHANICAL CHARACTERISTICS**
 - INSERTION FORCE: 5~20N
 - EXTRACTION FORCE: Initial:8~20N,ATER TEST 6~20N
 - DURABILITY:10,000CYCLES
- THE SHELL LENTH IS LESS THAN THE MINIMUM SPECIFIED BY THE USB TYPE C STANDARD,AS SUCH IS CONNOT INDENOENTLY BE GUARANTEED TO MEET ALL TYPE C MECHANICAL REQUIREMENTS.**

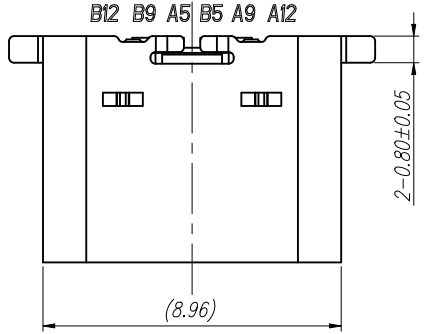
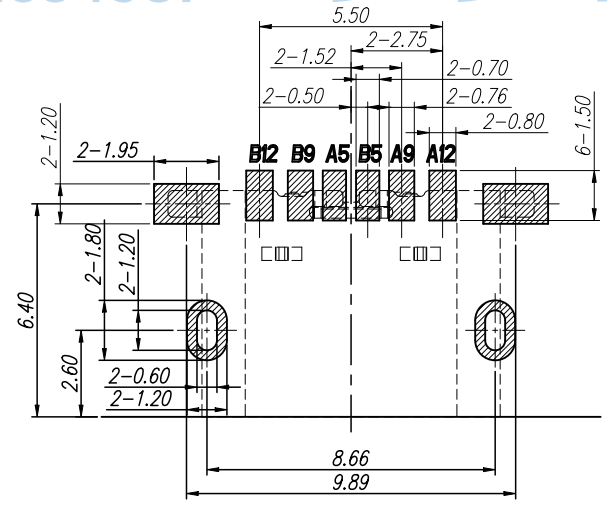
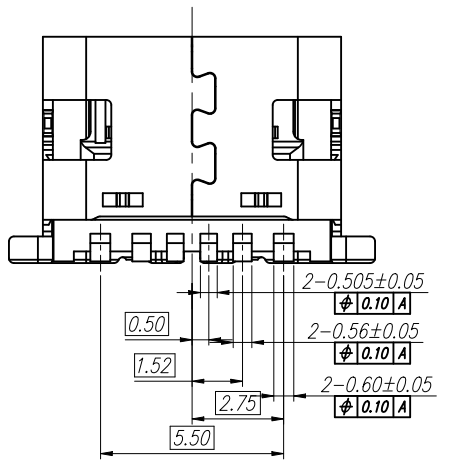
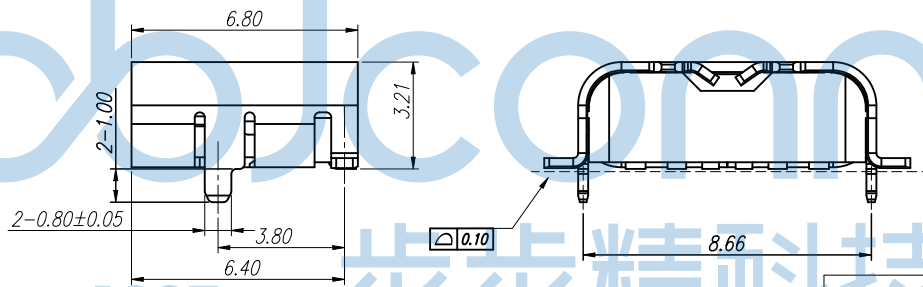
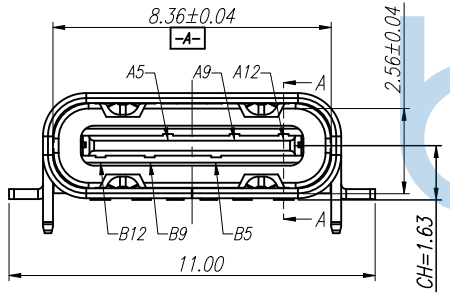

P.C.B LAYOUT VIEW TOLERANCE ±0.05

PIN ASSIGNMENT												BLADE	SHELL
A1	A2	A3	A4	A5	A6	A7	A8	A9	A10	A11	A12		
GND	TX1+	TX1-	VBUS	CC1	D+	D-	SBU1	VBUS	RX2-	RX2+	GND		
GND	RX1+	RX1-	VBUS	SBU2	D+	D-	CC2	VBUS	TX2-	TX2+	GND	GND	GND
B12	B11	B10	B9	B8	B7	B6	B5	B4	B3	B2	B1		

NO.	DESCRIPTION	QTY.	MATERIAL	FINISHED
4	MID PLATE	1 PCS	SUS301	None
3	CONTACT	1 SET	C2680	Ni 50~100u" Plated; After Au G/F Plated On Contact Area And Solder Area
2	IM HOUSING	1 PCS	LCP BLACK UL94V-0	None
1	SHELL	1 PCS	SUS201	Ni 50~120u" Plated

THIS DOCUMENT IS THE SOLE PROPERTY OF **深圳市步步精科技有限公司** (BBJconn Technology Co., Ltd.)

NAME: TYPE-C 6P 母座 板上型 前插后贴
端子SMT L=6.80 CH=1.63 编带

APPD. JM_Zheng
CHKD. LYX
DR. LYL

PJ. NO.: 126-221-060004-M3G
SIZE: A4 DRW NO.:
FINISH: SEE NOTES MAT'L.: SEE NOTES
SCALE: N/A REV.: A0 UNIT: mm PAGE: 1/2

PDWG.NO: 0851-1

REV.	ECN NO	CONTENT	DATE	ENGINEER
AO		Initial release	/	LYL

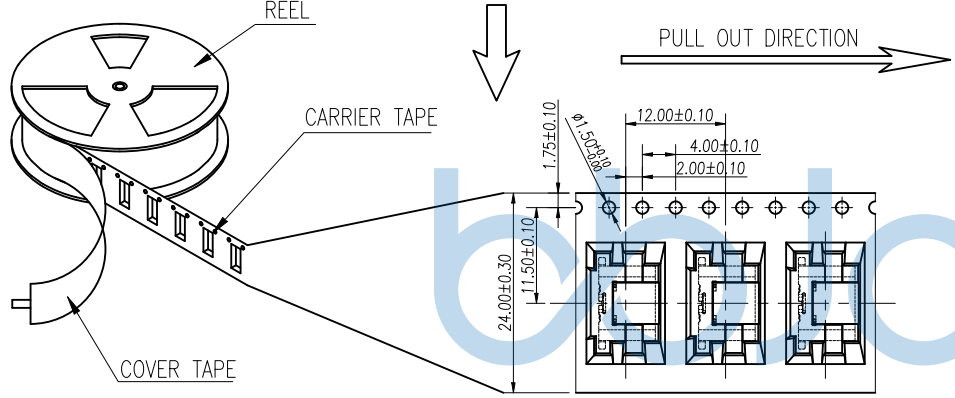
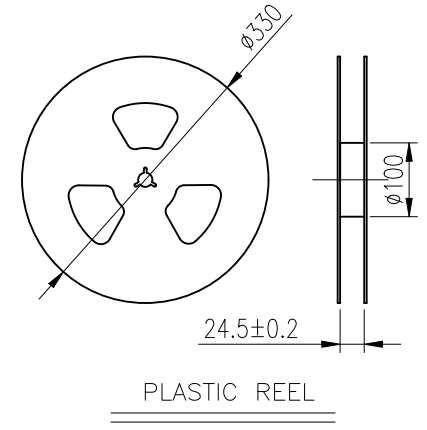
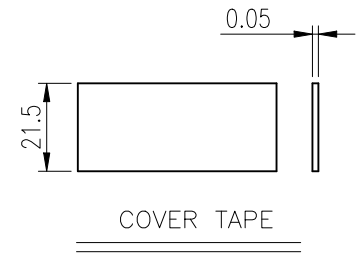
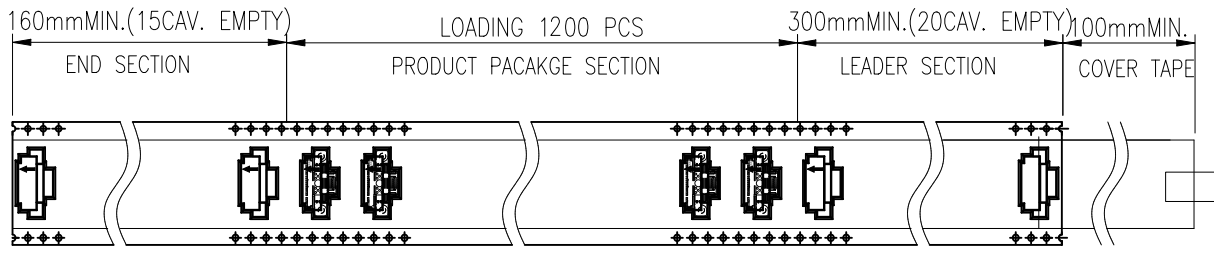

- NOTES 2:
- MATERIAL:
 - REEL AND AXLE: PS,BLUE
 - CARRIER TAPE: PET, LUCID
 - COVER TAPE: PS,TRANSPARENT
 - SHIPPING CARTON: CORRUGATED FIBER
 - DIMENSION:
 - REEL: W=24.5, φA=330
 - CARRIER TAPE: T=0.30 W=24.0
 - COVER TAPE: T=0.05 W=21.5
 - SHIPPING CARTON: L=335mm, W=335mm, H=365mm
 - QUANTITY:
 - PRIMAY PACKING: 1100 PCS/REEL
 - SECONARY PACKING: 12 REELS/CARTON(13200 PCS/CARTON)
 - PEELING RESISTANCE: 0.1~1.3N
 - PEELING SPEED: 300mm/minutes
 - PEELING ANGLE: 165°~180°

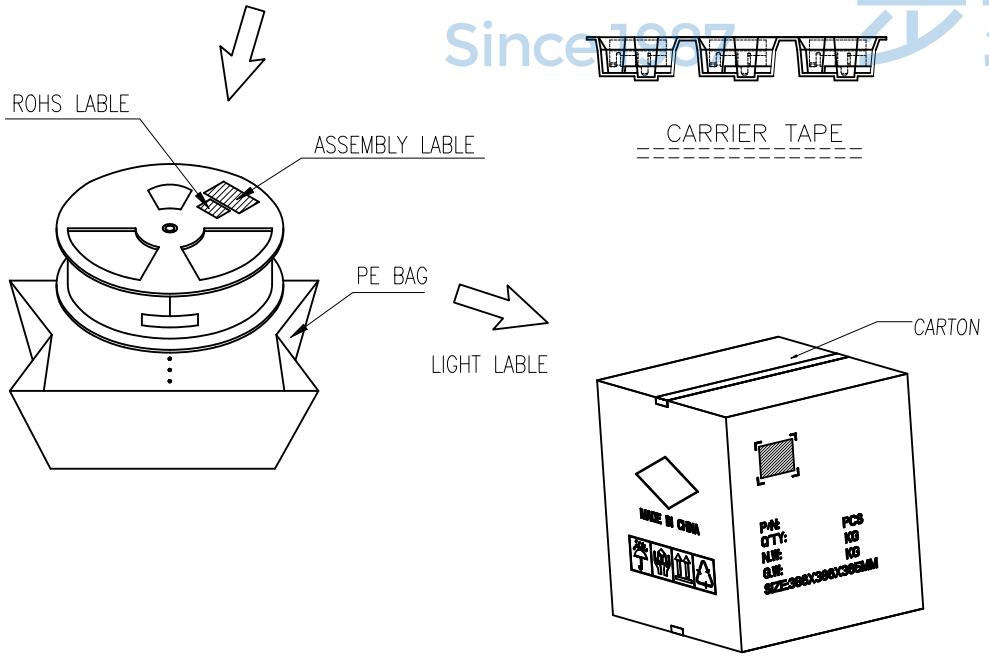

THIS DOCUMENT IS THE SOLE PROPERTY OF BBJconn Technology Co.,Ltd. Corporation AND SHOULD NOT BE USED IN WHOLE OR IN PART WITHOUT PRIOR WRITTEN PERMISSION.		深圳市步步精科技有限公司 .X: ±0.38 .X': ±3" .XX: ±0.25 .X'': ±2" .XXX: ±0.13 .X''': ±1"		NAME: TYPE-C 6P 母座 板上型 前插后贴 端子SMT L=6.80 CH=1.63 编带 APPD. JM_Zheng CHKD. LYX DR. LYL	
PDWG,NO: 0851-1		PJ. NO.: 126-221-060004-M3G SIZE: A4 DRW NO.: FINISH: SEE NOTES MAT'L.: SEE NOTES SCALE: N/A REV.: AO UNIT: mm PAGE: 2/2			