

REV.	ECN NO	CONTENT	DATE	ENGINEER
A0		Initial release	/	LYL

SPECIFICATION:

- ELECTRICAL CHARACTERISTICS:
 - CURRENT RATING: 3A
 - TEMPERATURE RANGE: -40 °C ~ 85 °C
 - CONTACT RESISTANCE: 30 MILLIONHM MAX.
 - DIELECTRIC WITHSTANDING VOLTAGE: 100 VAC r.m.s
 - INSULATION RESISTNACE: 100 MEGOHMS MIN.
- MECHANICAL CHARACTERISTICS
 - INSERTION FORCE: 5~20N
 - EXTRACTION FORCE: Initial:8~20N,ATER TEST 6~20N
 - DURABILITY:10,000CYCLES
- THE SHELL LENTH IS LESS THAN THE MINIMUM SPECIFIED BY THE USB TYPE C STANDARD,AS SUCH IS CONNOT INDENOENDENTLY BE GUARANTEED TO MEET ALL TYPE C MECHANICAL REQUIREMENTS.

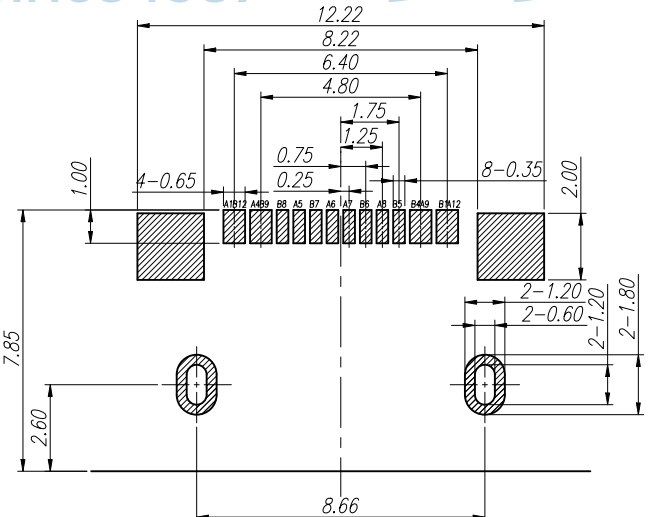
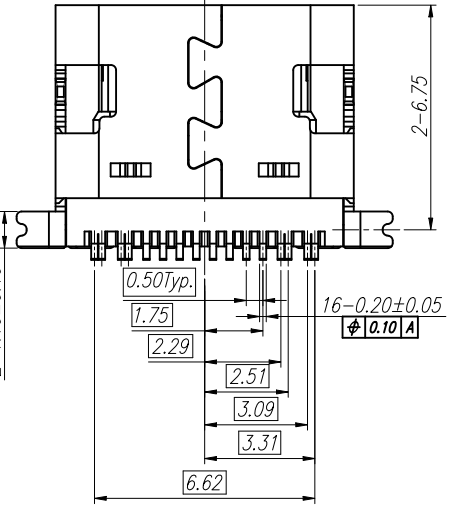
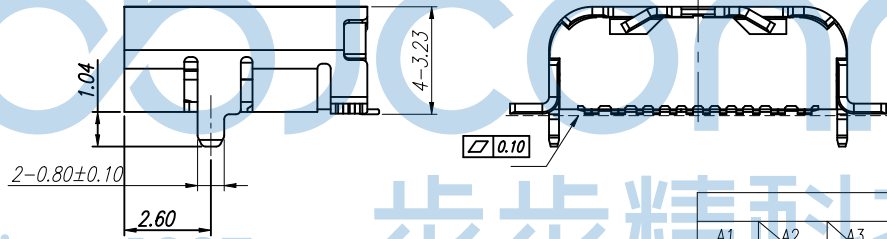
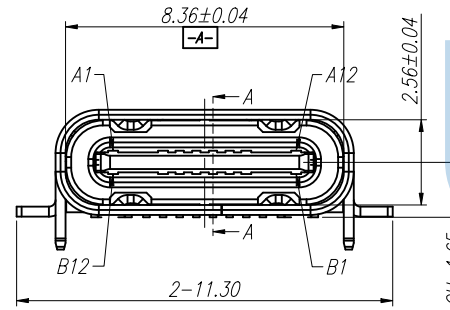
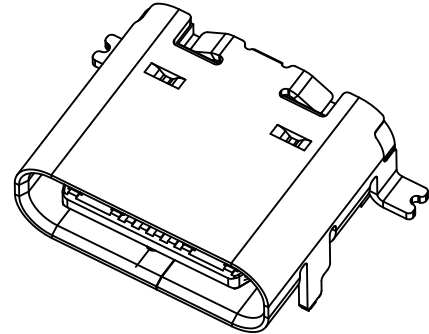
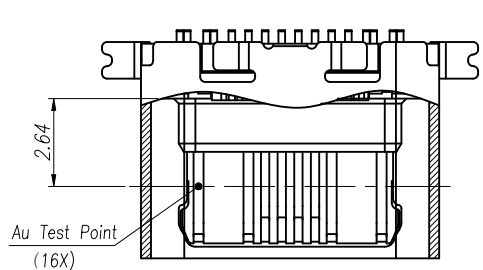
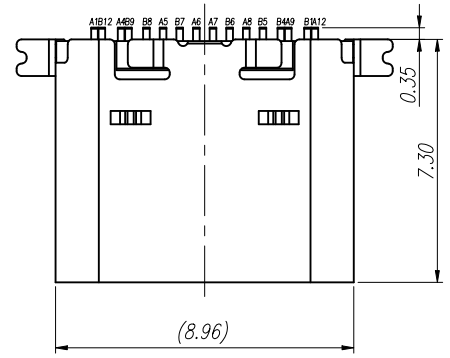

P.C.B LAYOUT VIEW TOLERANCE ±0.05

PIN ASSIGNMENT												BLADE	SHELL
A1	A2	A3	A4	A5	A6	A7	A8	A9	A10	A11	A12	GND	GND
GND	TX1+	TX1-	VBUS	CC1	D+	D-	SBU1	VBUS	RX2-	RX2+	GND		
GND	RX1+	RX1-	VBUS	SBU2	D-	D+	CC2	VBUS	TX2-	TX2+	GND	GND	GND
B12	B11	B10	B9	B8	B7	B6	B5	B4	B3	B2	B1		

NO.	DESCRIPTION	QTY.	MATERIAL	FINISHED
5	MID PLATE	1 PCS	SUS301 T=0.15	None
4	CONTACT 2	1 SET	C7025 T=0.15	Ni 50~100u" Plated; After Au 1u" Plated On Contact Area And Solder Area
3	CONTACT 1	1 SET	C7025 T=0.15	None
2	IM HOUSING	1 PCS	PA46 BLACK UL94V-0	None
1	SHELL	1 PCS	SUS304 T=0.30	Ni 50~120u" Plated

THIS DOCUMENT IS THE SOLE PROPERTY OF BBJconn Technology Co.,Ltd. Corporation AND SHOULD NOT BE USED IN WHOLE OR IN PART WITHOUT PRIOR WRITTEN PERMISSION. PDWG.NO: 0851-1

深圳市步步精科技有限公司

NAME: TYPE-C 16P 母座 板上型前插后贴 端子SMT L=7.30 CH=1.65 编带

APPD. JM_Zheng
CHKD. LYX
DR. LYL

PJ. NO.: 126-221-160012-M3G
SIZE: A4 DRW NO.:
FINISH: SEE NOTES MAT'L.: SEE NOTES
SCALE: N/A REV.: A0 UNIT: mm PAGE: 1/2

REV.	ECN NO	CONTENT	DATE	ENGINEER
A0		Initial release	/	LYL

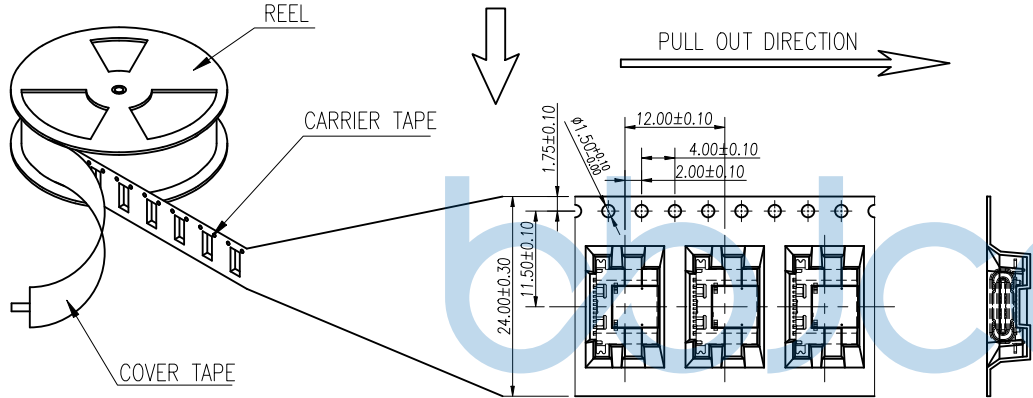
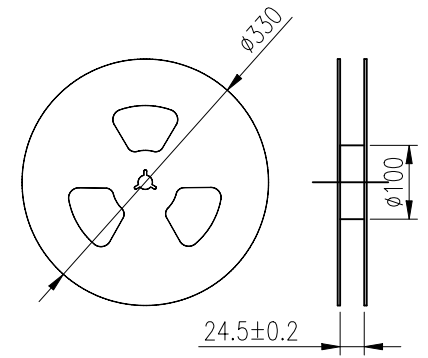
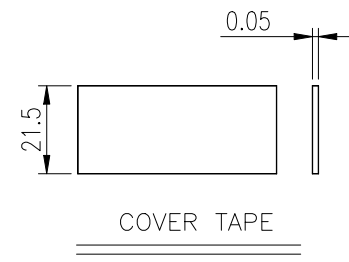
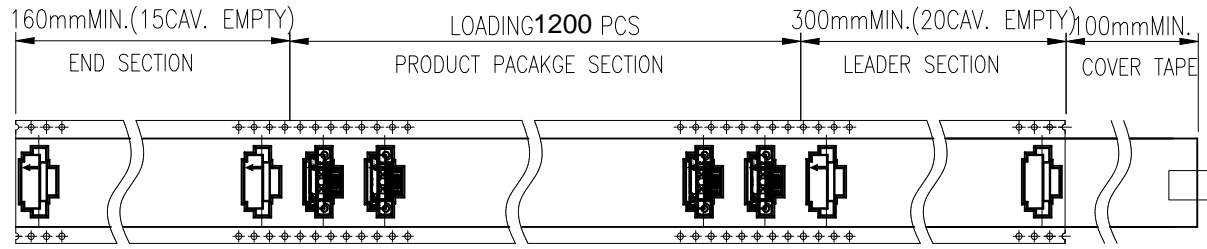

- NOTES 2:
- MATERIAL:
 - 1.1 REEL AND AXLE: PS,BLUE
 - 1.2 CARRIER TAPE: PET, LUCID
 - 1.3 COVER TAPE: PS,TRANSPARENT
 - 1.4 SHIPPING CARTON: CORRUGATED FIBER
 - DIMENSION:
 - 2.1 REEL: W=24.5, φA=330
 - 2.2 CARRIER TAPE: T=0.30 W=24.0
 - 2.3 COVER TAPE: T=0.05 W=21.5
 - 2.4 SHIPPING CARTON: L=335mm, W=335mm, H=425mm
 - QUANTITY :
 - 3.1 PRIMAY PACKING: 1200 PCS/REEL
 - 3.2 SECONARY PACKING: 12 REELS/CARTON(14400PCS/CARTON)
 - PEELING RESISTANCE: 0.1~1.3N
 - 4.1 PEELING SPEED: 300mm/minutes
 - 4.2 PEELING ANGLE: 165° ~180°

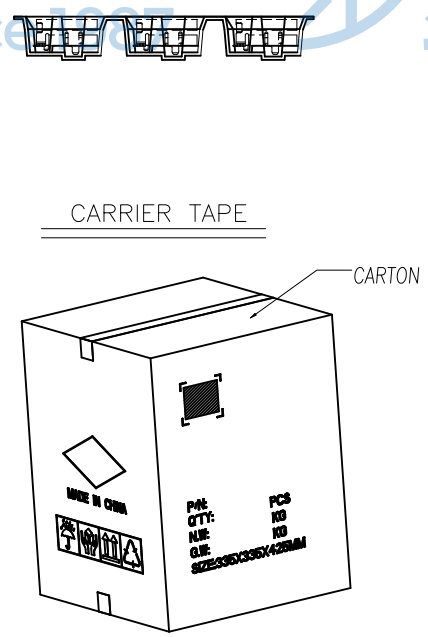
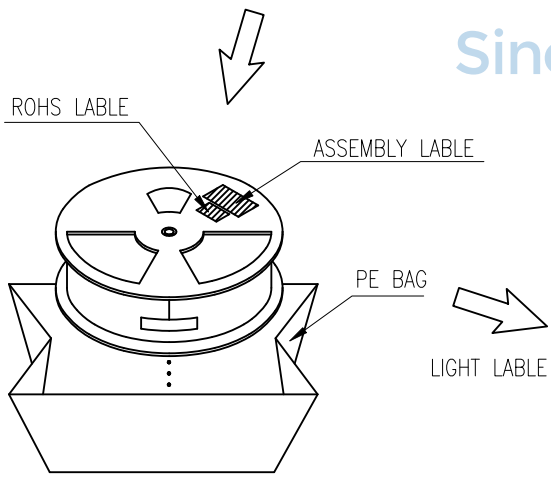

THIS DOCUMENT IS THE SOLE PROPERTY OF BBJconn Technology Co.,Ltd. Corporation AND SHOULD NOT BE USED IN WHOLE OR IN PART WITHOUT PRIOR WRITTEN PERMISSION.		深圳市步步精科技有限公司 .X: ±0.38 .X': ±3' .XX: ±0.25 .X'': ±2' .XXX: ±0.13 .XX': ±1'		NAME: TYPE-C 16P 母座 板上型前插后贴 端子SMT L=7.30 CH=1.65 编带 PJ. NO.: 126-221-160012-M3G SIZE: A4 DRW NO.: FINISH: SEE NOTES MAT'L.: SEE NOTES	
APPD.	JM_Zheng			SCALE: N/A	
CHKD.	LYX	DR.		REV.: AO	UNIT: mm
PDWG.NO:	0851-1	DR.		LYL	PAGE: 2/2