

REV.	ECN NO	CONTENT	DATE	ENGINEER
A0		Initial release	/	LYL

SPECIFICATION:

- 1.ELECTRICAL CHARACTERISTICS:
  - 1.1 CURRENT RATING: VBUS AND GND CONTACTS RATED AT 2.5A PARALLELED FOR A TOTAL OF 10A.
  - 1.2 TEMPERATURE RANGE: -40 °C ~ 85 °C
  - 1.3 CONTACT RESISTANCE: 30 MILLIONHM MAX.
  - 1.4 DIELECTRIC WITHSTANDING VOLTAGE: 100 VAC r.m.s
  - 1.5 INSULATION RESISTNACE: 100 MEGOHMS MIN.
- 2.MECHANICAL CHARACTERISTICS
  - 2.1 INSERTION FORCE: 5~20N
  - 2.2 EXTRACTION FORCE: Initial:8~20N;
  - 2.3 DURABILITY:10,000CYCLES
- 3.THE SHELL LENTH IS LESS THAN THE MINIMUM SPECIFIED BY THE USB TYPE C STANDARD,AS SUCH IS CONNOT INDENOENDENTLY BE GUARANTEED TO MEET ALL TYPE C MECHANICAL REQUIREMENTS.

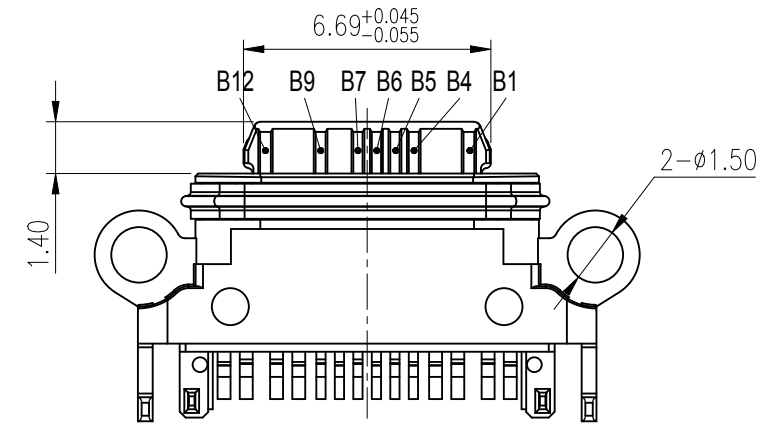
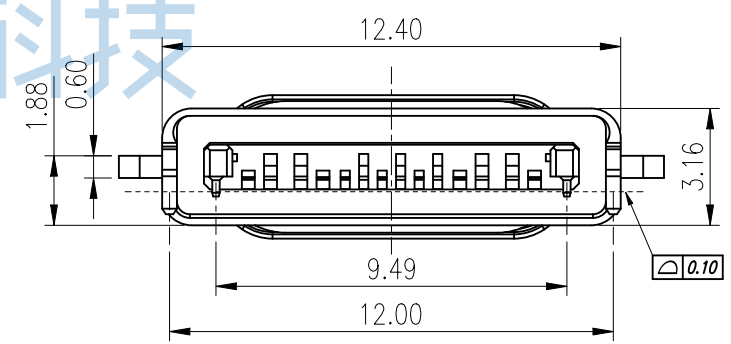
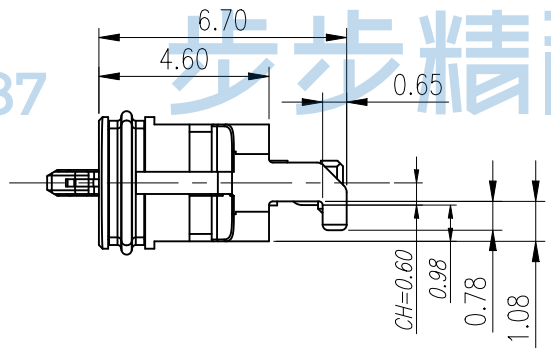
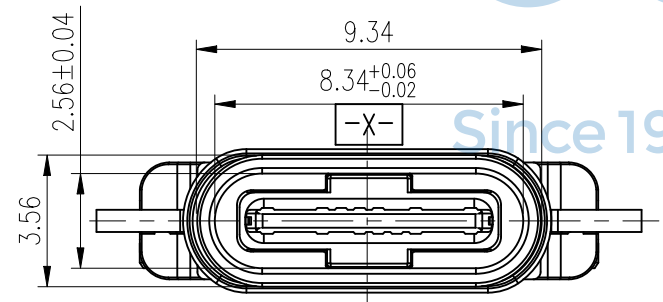
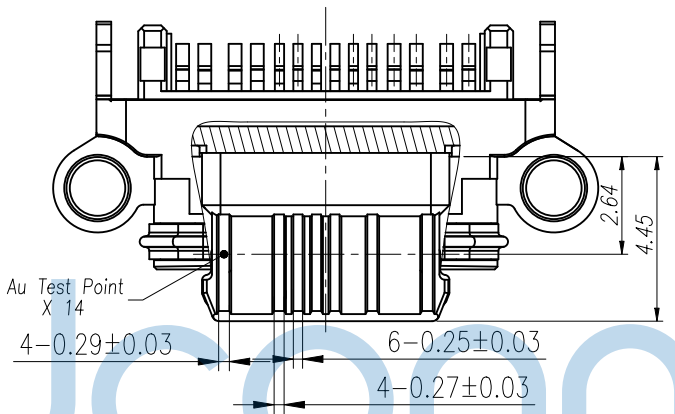
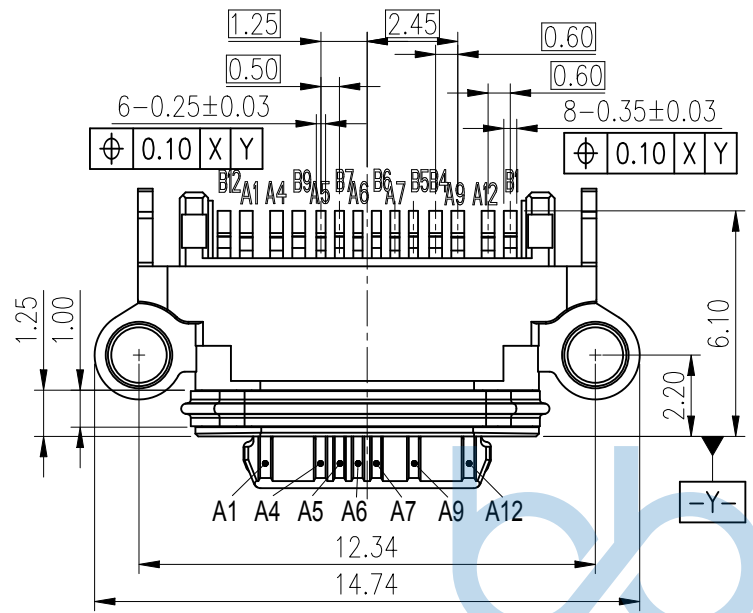

THIS DOCUMENT IS THE SOLE PROPERTY OF BBJconn Technology Co.,Ltd. Corporation AND SHOULD NOT BE USED IN WHOLE OR IN PART WITHOUT PRIOR WRITTEN PERMISSION.		<b>深圳市步步精科技有限公司</b> 工程部 APPROVED		NAME:TYPE-C 14P 防水母座 锁板式 端子SMT 舌片外漏1.40 沉板0.98 L=4.60 CH=0.60 IPX7 编带 APPD. JM_Zheng CHKD. LYX DR. LYL		PJ. NO.: 126-221-140002-M3G SIZE: A4 DRW NO.: FINISH: SEE NOTES MAT'L.: SEE NOTES SCALE: N/A REV.: A0 UNIT: mm PAGE: 1/4	
PDWG:NO: 0851-1		.X: ±0.38 .XX: ±0.25 .XXX: ±0.13	X': ±3" .X': ±2" .XX': ±1"				

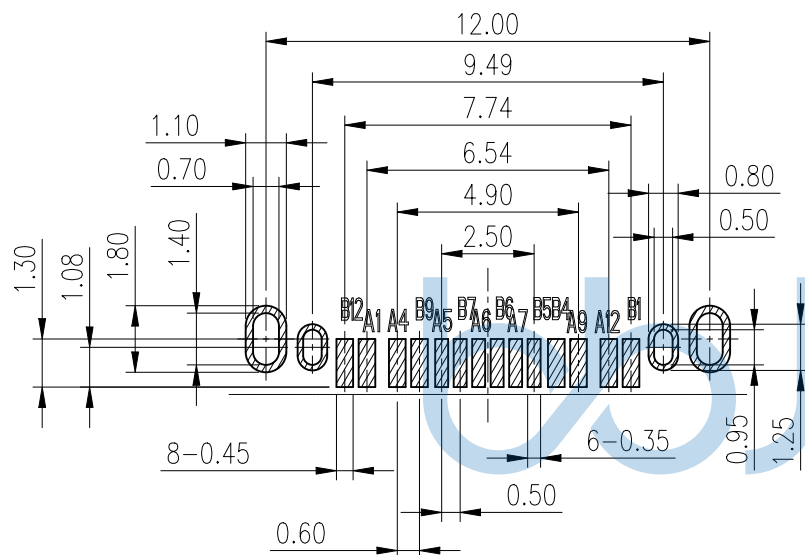

RECOMMENDED P.C.B. LAYOUT (THICKNESS: 0.80MM)  
UNLESS STATED TOLERANCE: ±0.05 (FOR REFERENCE)

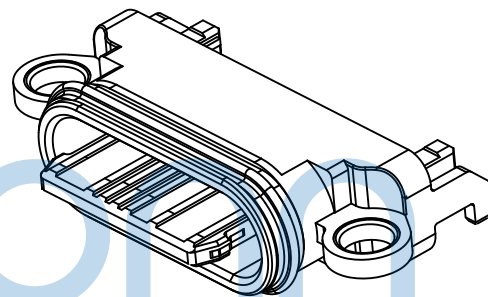

步步精科技

NO.	DESCRIPTION	QTY.	MATERIAL	FINISHED
6	Plate 1~3	1 PCS	STAINLESS STEEL SUS201	None
5	MID PLATE	1 PCS	STAINLESS STEEL SUS201	None
4	CONTACT 2	1 SET	COPPER ALLOY C2680	CONTACT AREA: Au 1U" PLATED .UNDER Ni PLATED OVERALL
3	CONTACT 1	1 SET	COPPER ALLOY C2680	SOLDER AREA: Au 1U" PLATED .UNDER Ni PLATED OVERALL
2	HOUSING	1 PCS	PLASTIC LCP	Black UL94V-0
1	DIE CASTING SHELL	1 PCS	Zn Al	Ni 50~100u"

PIN ASSIGNMENT												BLADE	SHELL
A1	A2	A3	A4	A5	A6	A7	A8	A9	A10	A11	A12		
GND	TX1+	TX1-	VBUS	CC1	D+	D-	SBU1	VBUS	RX2-	RX2+	GND		
GND	RX1+	RX1-	VBUS	SBU2	D-	D+	CC2	VBUS	TX2-	TX2+	GND	GND	GND
B12	B11	B10	B9	B8	B7	B6	B5	B4	B3	B2	B1		

THIS DOCUMENT IS THE SOLE PROPERTY OF **BBJconn Technology Co., Ltd.** CORPORATION AND SHOULD NOT BE USED IN WHOLE OR IN PART WITHOUT PRIOR WRITTEN PERMISSION.

**深圳市步步精科技有限公司**

NAME: TYPE-C 14P 防水母座 锁板式 端子SMT 舌片外漏1.40 沉板0.98 L=4.60 CH=0.60 IPX7 编带

APPD. JM\_Zheng  
CHKD. LYX  
DR. LYL

PJ. NO.: 126-221-140002-M3G  
SIZE: A4 | DRW NO.:  
FINISH: SEE NOTES | MAT'L.: SEE NOTES  
SCALE: N/A | REV.: A0 | UNIT: mm | PAGE: 2/4

REV.	ECN NO	CONTENT	DATE	ENGINEER
AO		Initial release		LYX

NOTES:

1. 材料: 硅胶 (道康宁RBB-2420-50+RBB-2420-70+迈图TSE221-4U HA (52±3)°) 颜色: 红色  
防火等级: UL94 HB 硬度: HA52±3度
2. 整体毛边0.05MAX, 无撕破. 划伤. 缺料等外观缺陷;
3. 标有"▼"记号者为重点检验尺寸。
4. 标有"(XX)"记号者为FAI检验尺寸。
5. 未标注尺寸公差为依自由公差为准。
6. 产品满足《环境有害物质管理要求》
7. 包装方式: 袋装 (5K/袋)
8. 过IR炉(265度) 3次后, 尺寸符合要求, 无开裂, 收缩变形, 变色等不良。
9. 拉长到如下图尺寸, 回弹后尺寸无明显变化, 符合图面管控要求。

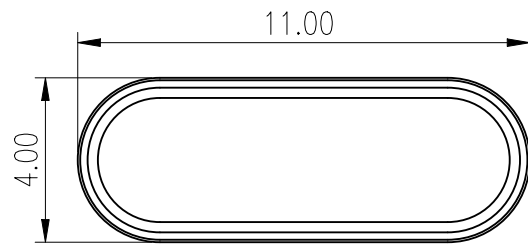
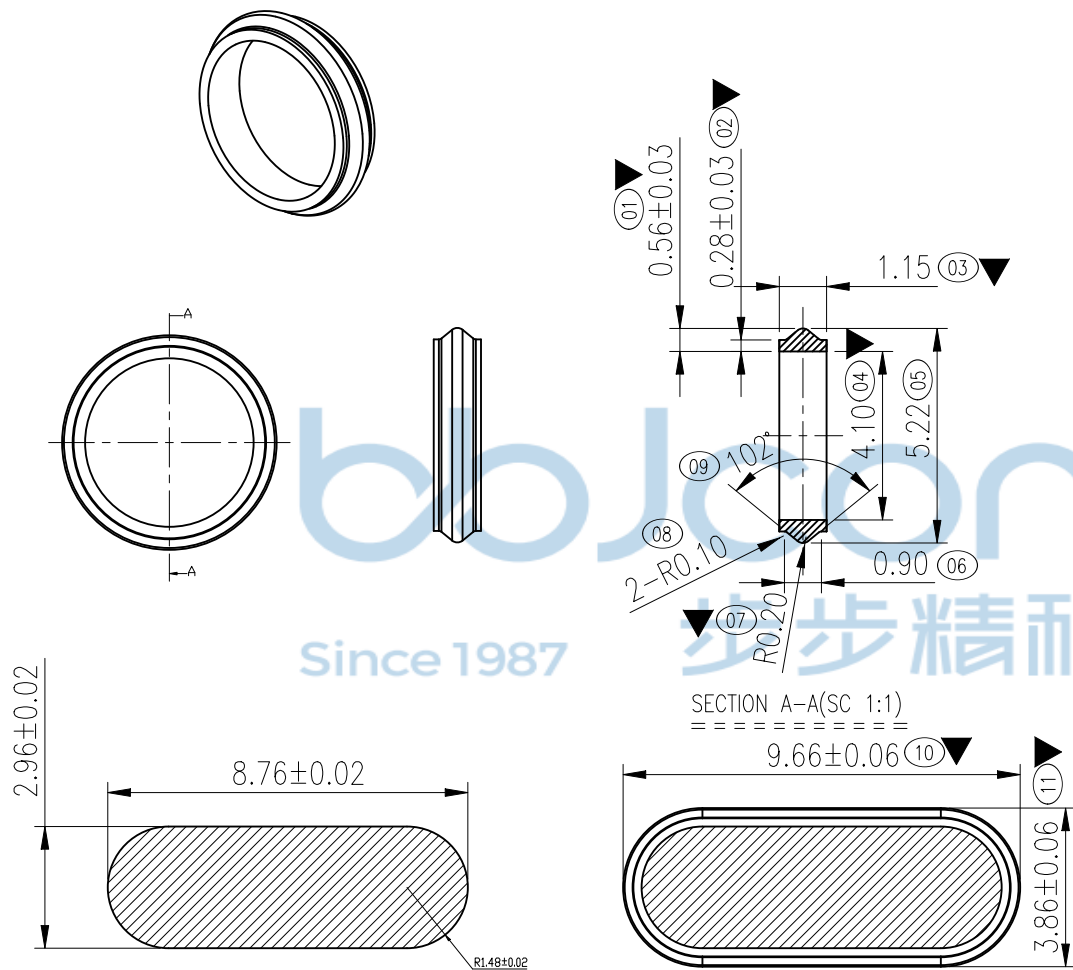

拉长示意图

旧料号
SJ-TC04-00-0003

治具/外壳装硅胶圈位置尺寸示意图

装硅胶圈后尺寸



THIS DOCUMENT IS THE SOLE PROPERTY OF BBJconn Technology Co., Ltd. Corporation AND SHOULD NOT BE USED IN WHOLE OR IN PART WITHOUT PRIOR WRITTEN PERMISSION.		<b>深圳市步步精科技有限公司</b>	
.X: ±0.10 .X': ±3" .XX: ±0.05 .X'': ±2" .XXX: ±0.02 .X''': ±1"		NAME: TYPE-C 14P 防水母座 锁板式 端子SMT 舌片外漏1.40 沉板0.98 L=4.60 CH=0.60 IPX7 编带	
APPD.	JM_Zheng	PJ. NO.: 126-221-140002-M3G SIZE: A4 DRW NO.:	
CHKD.	TSP	FINISH: SEE NOTES MAT'L.: SEE NOTES	
PDWG.NO:	0851-1	DR.	LYX
		SCALE: N/A	REV.: AO UNIT: mm PAGE: 3/4

REV.	ECN NO	CONTENT	DATE	ENGINEER
A0		Initial release	/	LYL

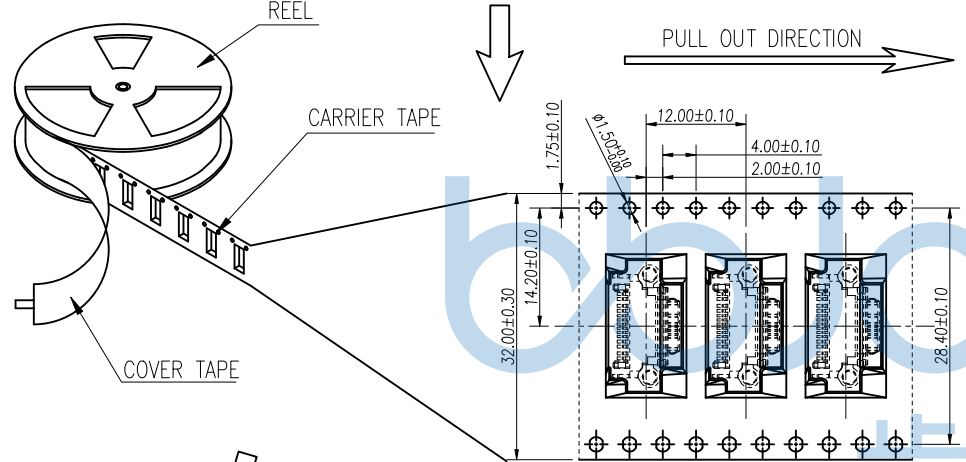
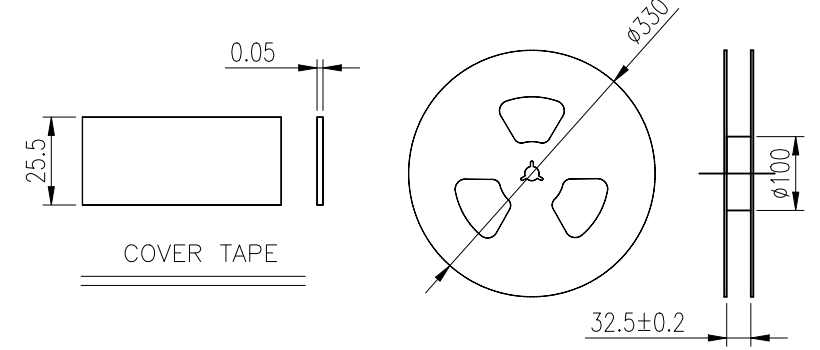
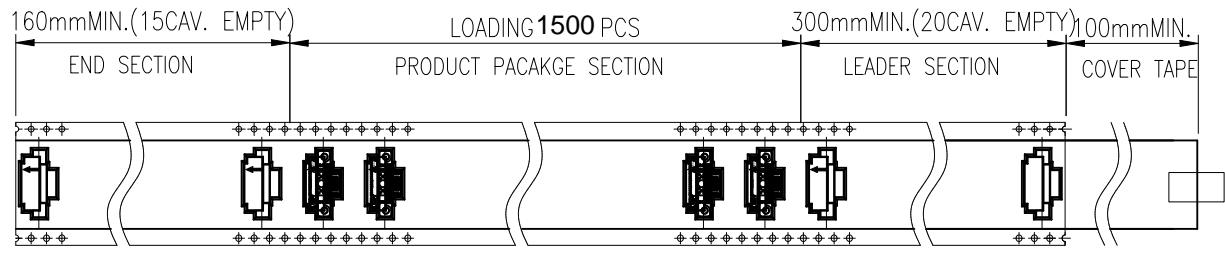

- NOTES 2:
- MATERIAL:
    - 1.1 REEL AND AXLE: PS,BLUE
    - 1.2 CARRIER TAPE: PET, LUCID
    - 1.3 COVER TAPE: PS,TRANSPARENT
    - 1.4 SHIPPING CARTON: CORRUGATED FIBER
  - DIMENSION:
    - 2.1 REEL: W=32.5, øA=330
    - 2.2 CARRIER TAPE: T=0.50 W=32.0
    - 2.3 COVER TAPE: T=0.05 W=25.5
    - 2.4 SHIPPING CARTON: L=335mm, W=335mm, H=425mm
  - QUANTITY:
    - 3.1 PRIMARY PACKING: 1500 PCS/REEL
    - 3.2 SECONDARY PACKING: 10 REELS/CARTON( 15000PCS/CARTON)
  - PEELING RESISTANCE: 0.1~1.3N
    - 4.1 PEELING SPEED: 300mm/minutes
    - 4.2 PEELING ANGLE: 165° ~180°

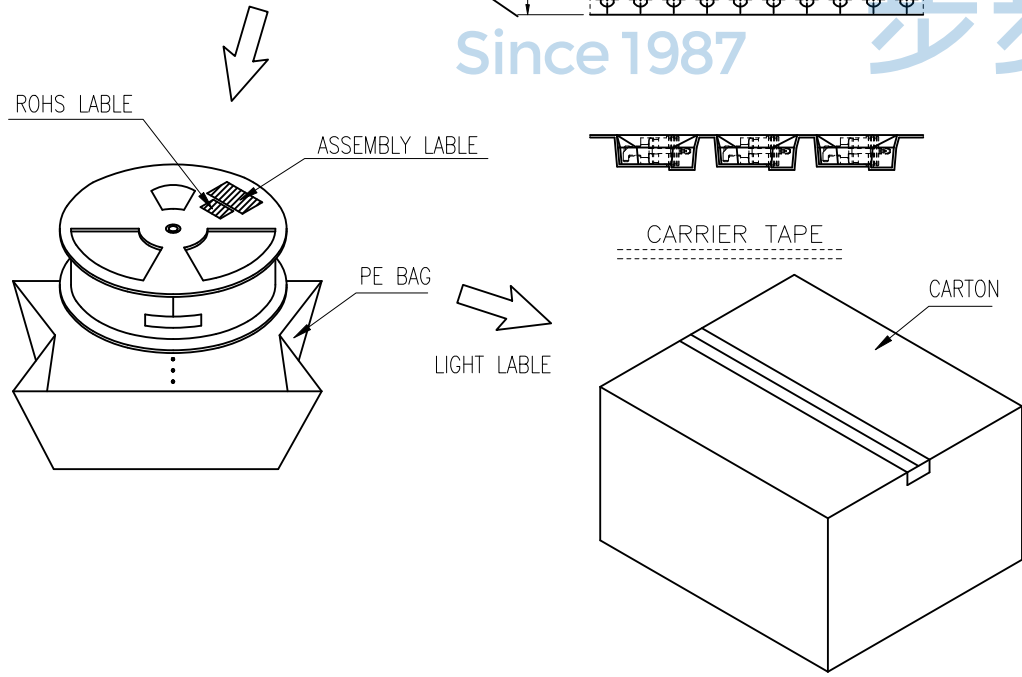

THIS DOCUMENT IS THE SOLE PROPERTY OF BBJconn Technology Co.,Ltd. Corporation AND SHOULD NOT BE USED IN WHOLE OR IN PART WITHOUT PRIOR WRITTEN PERMISSION.		<b>深圳市步步精科技有限公司</b>	
.X: ±0.38    .X': ±3" .XX: ±0.25    .X'': ±2" .XXX: ±0.13    .X''': ±1"		NAME:TYPE-C 14P 防水母座 锁板式 端子SMT 舌片外漏1.40 沉板0.98 L=4.60 CH=0.60 IPX7 编带	
APPD.	JM_Zheng	PJ. NO.: 126-221-140002-M3G SIZE: A4   DRW NO.:	
CHKD.	LYX	FINISH: SEE NOTES    MAT'L.: SEE NOTES	
PDWG,NO:	0851-1	SCALE: N/A	REV.: A0    UNIT: mm    PAGE: 4/4