

NOTE:

1. MATERIAL SPECIFICATION:
 1. HOUSING: HIGH TEMPERATURE RESISTANT PLASTIC, UL94 V-0. LCP
 2. CONTACTS: COPPER ALLOY C2680
 3. MID PLATE: STAINLESS STEEL SUS304
2. PLATING SPECIFICATION:
 - 2-1. CONTACTS:
 - Ni 50u" MIN. UNDER PLATED OVER ALL.
 - Au PLATED ON THE FUNCTIONAL AREA OF CONTACT.
 - 2-2. FRONT SHELL:
 - Ni 30u" MIN. UNDER PLATED OVER ALL.
3. MECHANICAL PERFORMANCE,
 - 3-1. INSERTION FORCE: 0.5~2.0kgf.
 - 3-2. REMOVAL FORCE: 0.8kgf~2.0kgf.
 - 3-3. DURABILITY: 10000 CYCLES.
4. ELECTRICAL PERFORMANCE,
 - 4-1. CURRENT RATING: 5A
VOLTAGE RATING: 20V
 - 4-2. INSULATION RESISTANCE: 100MΩ MIN
 - 4-3. CONTACT RESISTANCE: 30mΩ MAX
 - 4-4. DIELECTRIC WITHSTAND VOLTAGE, AC 100V FOR 1 MINUTE.
5. ENVIRONMENTAL PERFORMANCE:
 - OPERATING TEMPERATURE: -30°C~+80°C.
6. IR REFLOW:
 - THE PEAK TEMPERATURE ON THE BOARD SHALL BE MAINTAINED FOR 10 SECONDS AT 260°C.

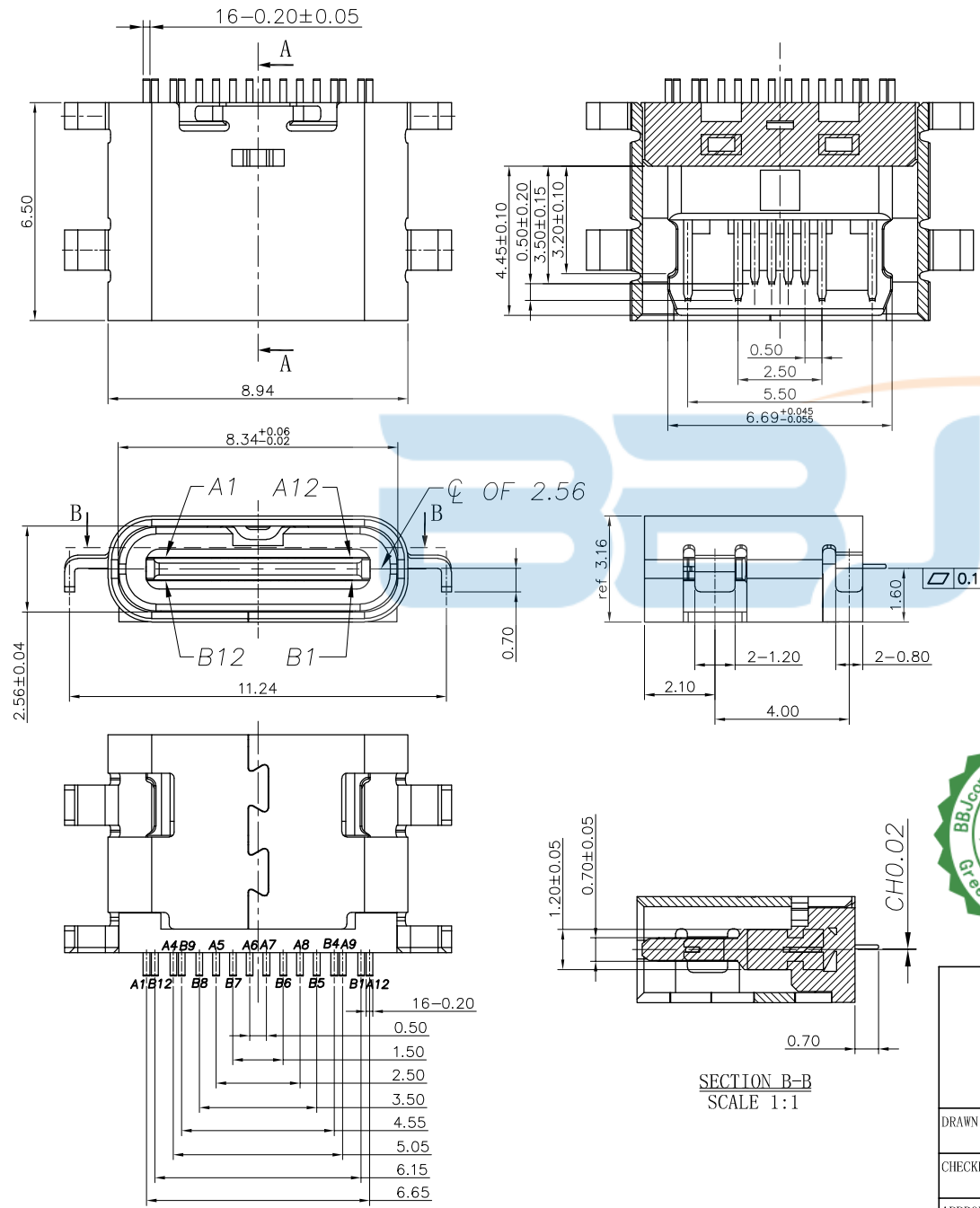

SECTION B-B
SCALE 1:1

TOLERANCE UNSPECIFIED		深圳市步步精科技有限公司 TITLE: TYPE-C 16P 母座L=6.5沉板1.6 CH0.02 铜合金端子			
.0	±0.35				
.00	±0.25	DRAWN		DATE	HMY
.000	±0.15	CHECKED		DATE	LYX
X.°	±2.00°	APPROVED		DATE	LJP
CUSTOMER DRAWING		SIZE: A4	UNIT: mm.	PART. NO:	UC. 01. 31-11-0006
		SCALE: 1:1	PROJECTION	REV.: A	
		DWG	PATH	0100-2	PATH 1/3

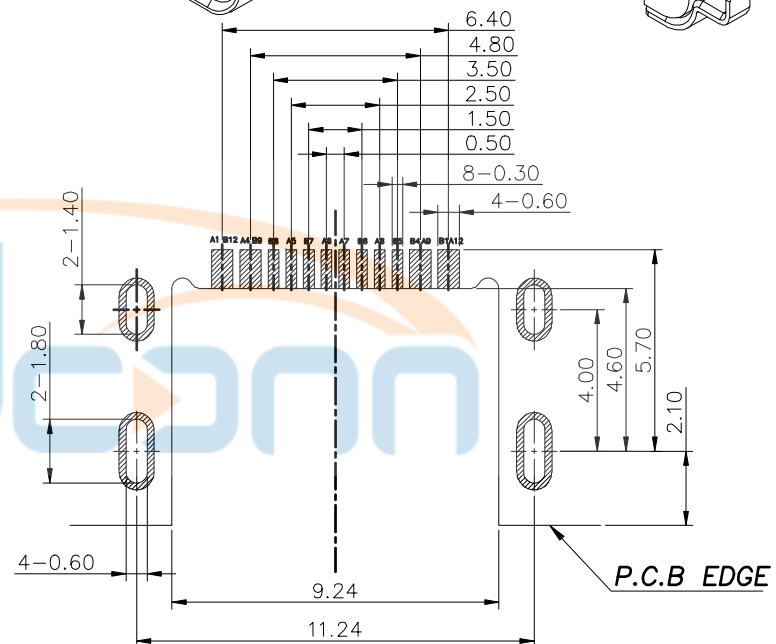
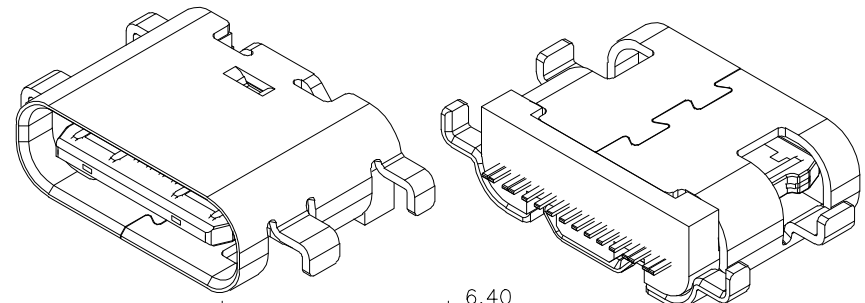

USB TYPE-C PIN ASSIGNMENTS

PIN NUMBER	SIGNAL NAME	PIN NUMBER	SIGNAL NAME
A1	GND	B12	GND
A4	VBUS	B9	VBUS
A5	CC1	B8	SBU2
A6	Dp1	B7	Dn2
A7	Dn1	B6	Dp2
A8	SBU1	B5	CC2
A9	VBUS	B4	VBUS
A12	GND	B1	GND

RECOMMEND P.C.B LAYOUT (COMPONENT SIDE)

TOLERANCE FOR PCB LAYOUT IS ± 0.05



TOLERANCE UNSPECIFIED

.0	± 0.35
.00	± 0.25
.000	± 0.15
1"	± 2.00

深圳市步步精科技有限公司

TITLE: TYPE-C 16P 母座L=6.5沉板1.6 CH0.02 铜合金端子

DRAWN DATE	HMY	SIZE:A4	UNIT:mm	PART. NO:	UC.01.31-11-0006
CHECKED DATE	LYX	SCALE: 1:1	PROJECTION	REV. : B	
APPROVED DATE	LJP	DWG PATH	0100-2	PATH	2/3

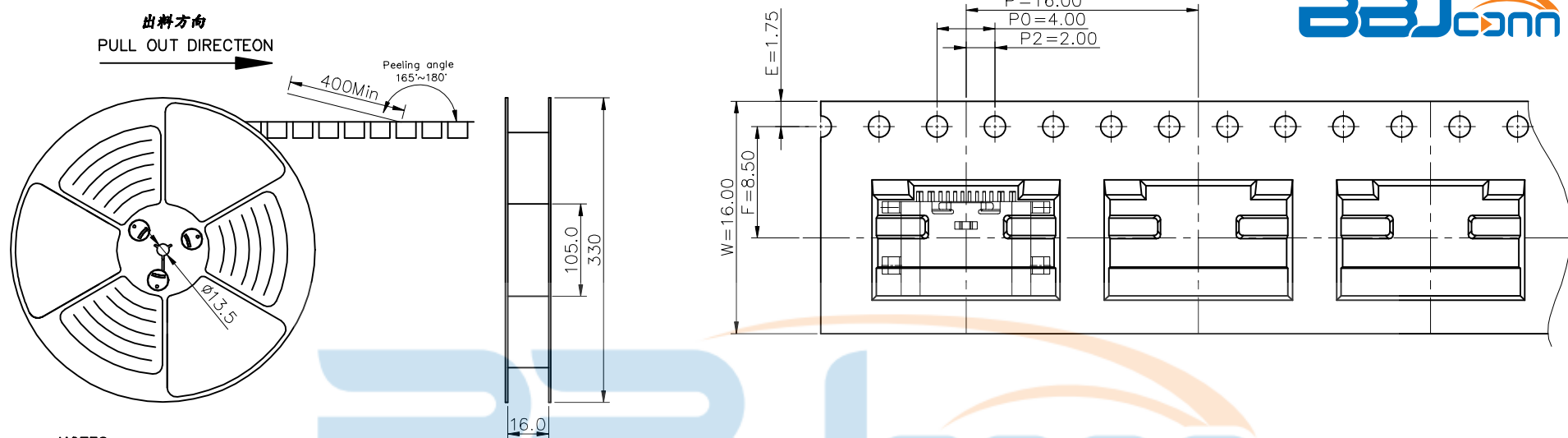

NOTES

1. 帶子引導長度
LEAD TAPE LENGTH
出料方向
PULL OUT DIRECTEON

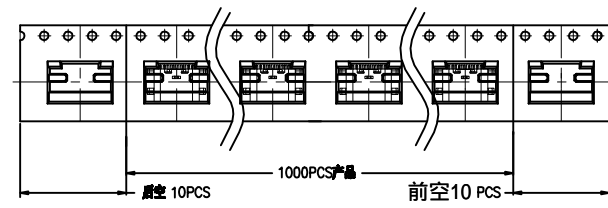

2. 上帶剝力力為：0.1~1.3N(10.2gf~130gf)
PEELING OFF FORCE OF TOP TAPE:0.1~1.3N(10.2gf~130gf)
出貨運輸過程中一定注意：
THIS REQUIREMENT SHOULD BE APPLIED AT SHIPMENT：
卷帶在運輸過程中不能散開
PEELING OFF SHOULD NOT BE ALLOWED DURING TRANSPORTATION

TAPE & REEL 14 PCS

1 REEL
= 1000 PCS

BOX

DIMENSIONS:
33.5X33.5X30.5

1 CARTON
=14 REELS
=14000 PCS

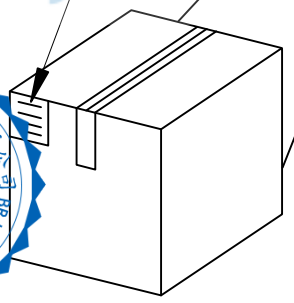
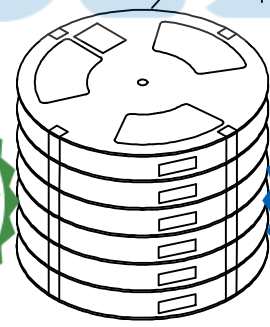

TOLERANCE UNSPECIFIED	
.0	±0.35
.00	±0.25
.000	±0.15
1. "	±2.00"
CUSTOMER DRAWING	

深圳市步步精科技有限公司

TITLE: TYPE-C 16P 母座L=6.5沉板1.6 CHO.02 铜合金端子

包裝明細表 (The detail of the packing)Carton						
產品料號 (Product No.)	包裝容量 (Packing Capacity)			重量 Weight (Kg)		
	pcs/box	boxs/Carton	Pcs/Box	N.W./Pcs	N.W./Box	G.W./Box
	1000	14	14000	—	—	—

DRAWN DATE	HMY	SIZE:A4	UNIT:mm	PART. NO:	UC.01.31-11-0006	
CHECKED DATE	LYX	SCALE: 1:1	PROJECTION			REV.: B
APPROVED DATE	LJP	DWG PATH	0100-2		PATH	3/3