

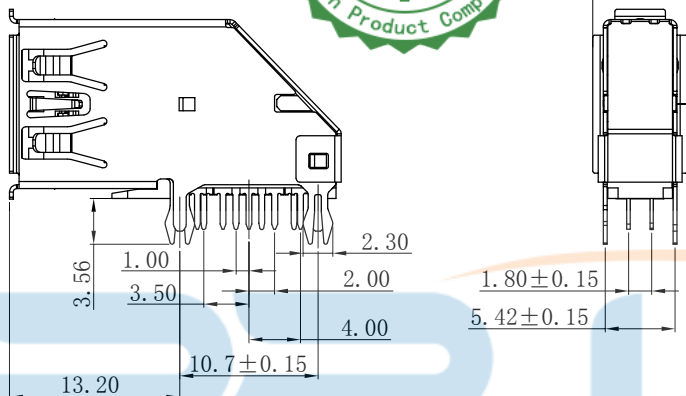

REV.	DESCRIPTION	NAME	DATE
A	NEWS ISSUE		

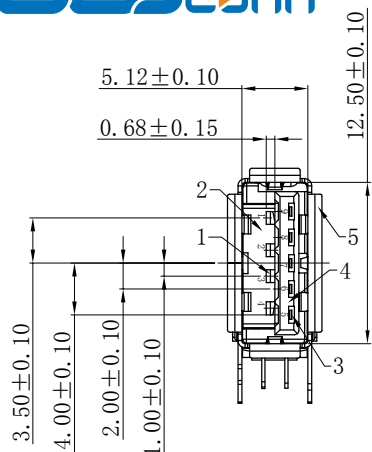

Pin NUMBER	SIGNAL NAME
1	VBUS
2	D-
3	D+
4	GND
5	StdA_SSRX-
6	StdA_SSRX+
7	GND_DRAIN
8	StdA_SSTX-
9	StdA_SSTX+
Shell	Shield

- NOTES:
- ELECTRONIC:
 - CONTACT RESISTANCE: 30mohm MAX
 - INSULATION RESISTANCE: 1000 Mohm MIN
 - WITHSTAND VOLTAGE: AC 500V, 1min.
 - MECHANICAL:
 - DURABILITY: 5000 CYCLE.
 - ENVIRONMENT CHARACTERISTICS:
 - OPERATING TEMPERATURE: -55° C TO +105° C
 - RECOMANDER PCB THICKNESS 1.2 TO 1.60MM
 - PART NO:

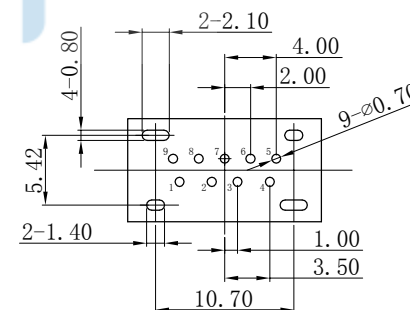
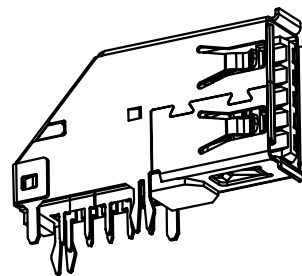
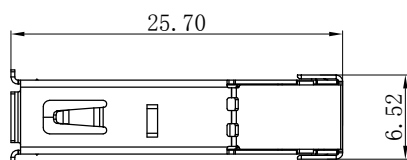
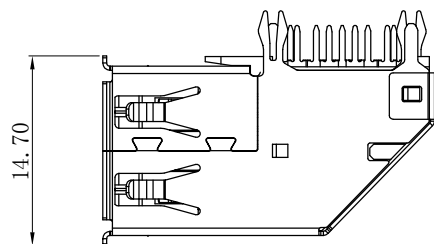

PCB LAYOUT (TOP VIEW)

NO.	DESCRIPTION	MATERIAL	QTY.	REMARK
④	SHELL	SUS201/304	1	Ni PLATED
③	CONTACT FOOT 2#	COPPER ALLOY	4	GOLD/TIN PLATED
②	CONTACT FOOT 1#		5	Ep/Sn Sn 100μ"Min EP/Au AU 1μ"/15μ"/30μ"
①	HOUSING	LCP (BLACK)/(BLUE)	1	UL94V-0

TOLERANCE UNSPECIFIED

X.X	±0.30
X.XX	±0.20
X.XXX	±0.10
ANG.	±° 5

CUSTOMER DRAWING

BBJconn 深圳市步步精科技有限公司

TITLE:
USB 3.0 AF 90度 四脚插 鱼叉脚 侧插 L=25.70 H=6.52 端子DIP 卷边 LCP蓝胶 不锈钢壳

DRAWN/ DATE	设计 ZY	SIZE:A4	UNIT:MM.	PART.NO:	UB.03.41-33-W002
CHECKED/ DATE	审核 LYX	SCALE: 1:1	PROJECTION	REV.:	版本
APPROVED/ DATE	核准 LJP	DWG. PATH	0540-1	SHEET:	页码



REV.	DESCRIPTION	NAME	DATE
A	NEWS ISSUE		

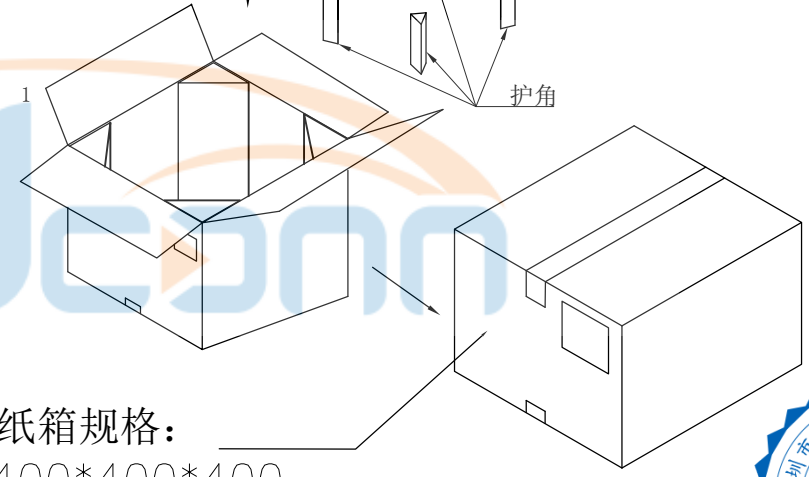
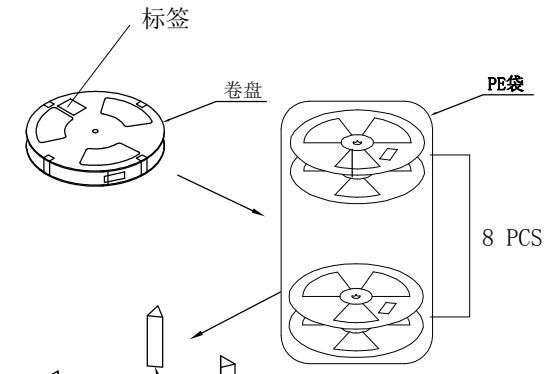
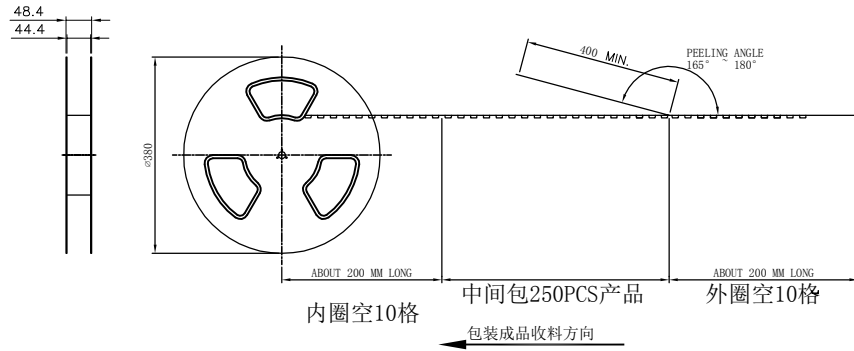

纸箱规格:
400*400*400

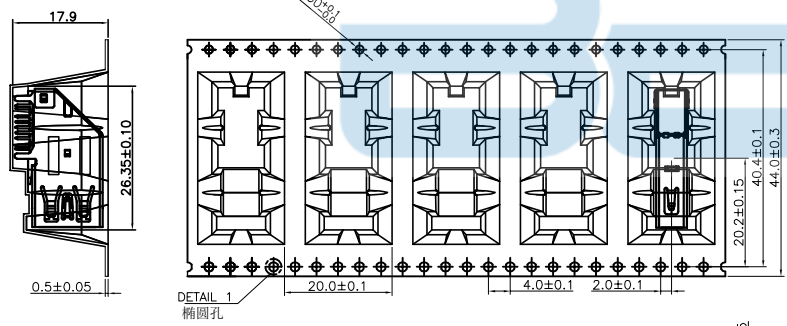

NOTE:

- MATERIAL:
BOX: FIBREBOARD, CORRUGATED, DOUBLE WALL.
TAPE: POLYSTYRENES, HEAT-RESISTANT TEMPERATURE: 120°C, BLACK COLOR.
REEL: POLYSTYRENES, HEAT-RESISTANT TEMPERATURE: 70°C, BLUE COLOR.
BAG: POLYETHYLENE, HEAT-RESISTANT TEMPERATURE: 100°C.
- PEELING STRENGTH: 0.1 ~ 1.3 N (10 ~ 130 GRAMS)
- PEELING SPEED: 300 mm/min.
- EACH BAG SHALL BE INCLUDED DESICCANT.

250	8	2000 PCS	-- KG	-- KG
PCS/ REEL	REELS/ CARTON	QUANTITY	GROSS WEIGHT	NET WEIGHT

TOLERANCE UNSPECIFIED		深圳市步步精科技有限公司 TITLE: USB 3.0 AF 90度 四脚插 侧插 鱼叉脚 L=25.70 H=6.52 端子DIP 卷边 LCP蓝胶 不锈钢壳					
X.X	±0.30						
X.XX	±0.20	DRAWN/ DATE	设计 ZY	SIZE:A4	UNIT:MM.	PART.NO:	UB.03.41-33-W002
X.XXX	±0.10	CHECKED/ DATE	审核 LYX	SCALE: 1:1	PROJECTION	REV.: 版本	
ANG.	±° 5	APPROVED/ DATE	核准 LJP	DWG. PATH	0540-1	SHEET: 页码	
CUSTOMER DRAWING							