

REV.	ECN NO	CONTENT	DATE	ENGINEER
A0			2023 20/04	

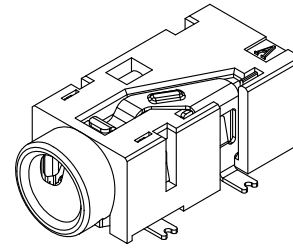

3D VIEW

- CONTACT CURRENT RATING: 1A.
- CONTACT RESISTANCE: 50 mΩ MAX. ;
- INSULATION RESISTANCE: 100MΩ MIN. ;
- DIELECTRIC WITHSTANDING: 500V AC MIN. ;
- DURABILITY: 5,000 CYCLES MIN. ;
- CONNECTOR MATING FORCES: 29.4N (3.00Kgf) MAX. ;
- CONNECTOR UNMATING FORCES: 2.94N(0.30Kgf) MIN. ;

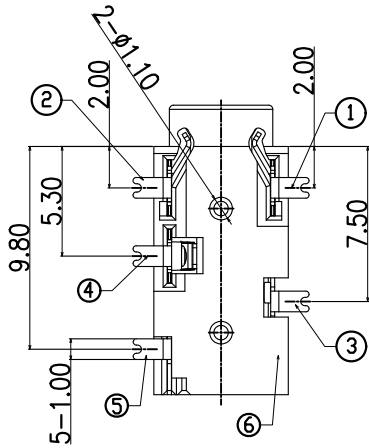
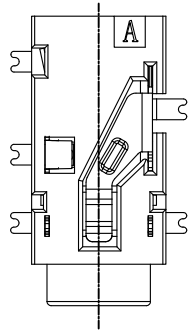
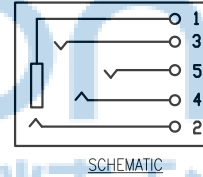
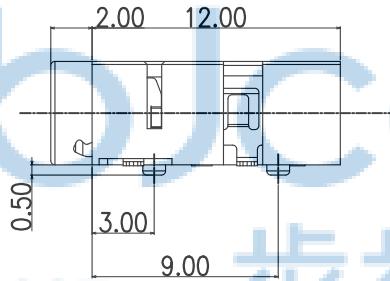
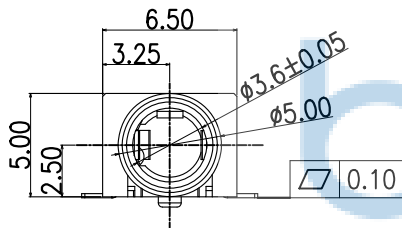

SCHEMATIC

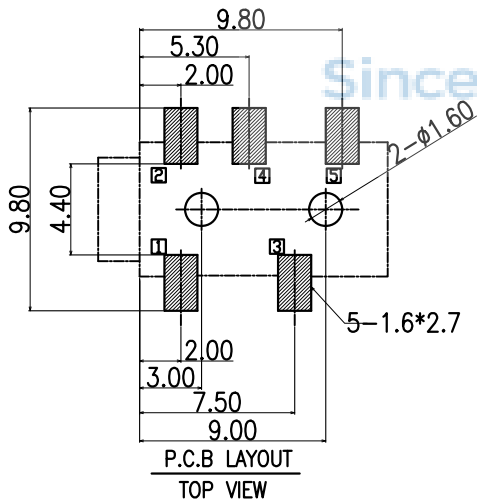

P.C.B LAYOUT  
TOP VIEW

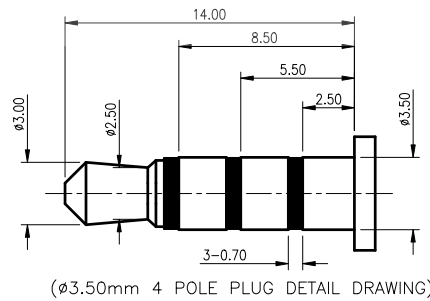

(φ3.50mm 4 POLE PLUG DETAIL DRAWING)



ITEM	NAME	Q'TY	DESCRIPTION	NOTE
6	HOUSING	1	PPA COLOR BLACK	
5	CONTACT 5#	1	PHOSPHOR BRONZE; NICKEL UNDER PLATING OVERALL,TIN WHOLE THE OVERALL	
4	CONTACT 4#	1	PHOSPHOR BRONZE; NICKEL UNDER PLATING OVERALL,TIN WHOLE THE OVERALL	
3	CONTACT 3#	1	PHOSPHOR BRONZE; NICKEL UNDER PLATING OVERALL,TIN WHOLE THE OVERALL	
2	CONTACT 2#	1	PHOSPHOR BRONZE; NICKEL UNDER PLATING OVERALL,TIN WHOLE THE OVERALL	
1	CONTACT 1#	1	PHOSPHOR BRONZE; NICKEL UNDER PLATING OVERALL,TIN WHOLE THE OVERALL	

THIS DOCUMENT IS THE SOLE PROPERTY OF BBJconn Technology Co.,Ltd. Corporation AND SHOULD NOT BE USED IN WHOLE OR IN PART WITHOUT PRIOR WRITTEN PERMISSION.		<b>深圳市步步精科技有限公司</b> .X: ±0.38 .XX: ±0.25 .XXX: ±0.13 X*: ±3' X*: ±2' XX*: ±1'	
APPD.	JM_Zheng	23/05/02	NAME: 3.5耳机座 有头 五脚贴片 带柱 四节 (PJ35A046-F05T1BR-B)
CHKD.	LYX	23/05/02	PJ. NO.: PJ.01.22-01-3001 SIZE: A4   DRW NO.:
PDWG.NO:	0076-1	DR.	SGF 23/05/02 FINISH: SEE NOTES   MAT'L.: SEE NOTES SCALE: N/A   REV.: A0   UNIT: mm   PAGE: 1/1

1载带=1000PCS

1外箱=1000PCSX10盘载带=10000PCS

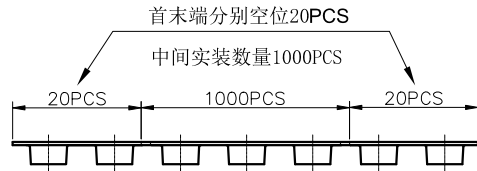

载带引出方向  
\* 载带包装时请依此引出方向为标准

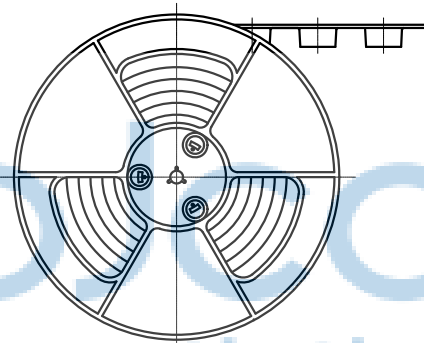

卷盘包装示意

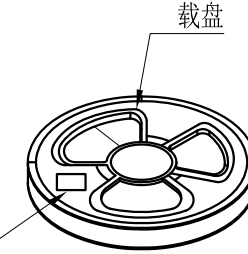
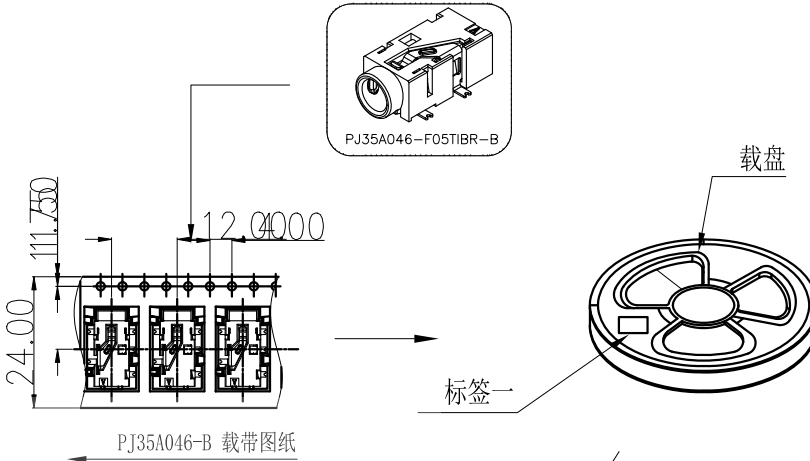

三角板  
共4块

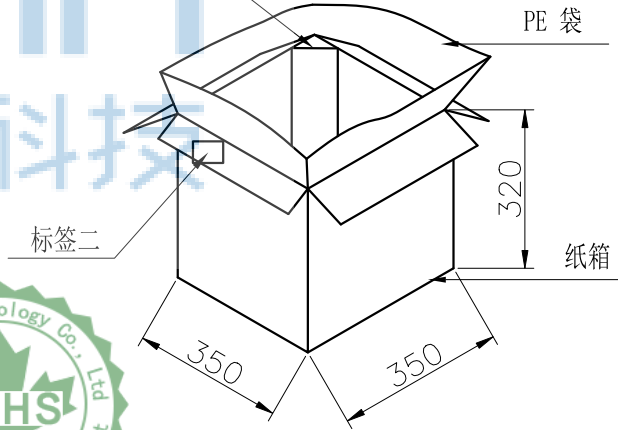

包材名称	材料及厚度(mm)	规格(mm)
PJ35A046-B 载带	P.S(白色透明)T=0.30	12500X24.00X5.10
载盘	HI P.S(蓝色)	ø330X30.40
自粘带	PET(白色透明)	W=21.30 T=0.06
PE-770X750X0.35-A	PE(白色透明)	770X750X0.35
ZK-350X350X320-A	K=K t=4	350X350X320
三角板	A=A+ t=4	260X300

备注:

1. 每载盘内必须放干燥剂;
2. 每箱必须按照要求增加PE防水袋包装;
3. 参考《高温材料管理规定》进行作业;
4. 条码+二维码标签和交货标签按客户要求制作;



THIS DOCUMENT IS THE SOLE PROPERTY OF BBJconn Technology Co.,Ltd. Corporation AND SHOULD NOT BE USED IN WHOLE OR IN PART WITHOUT PRIOR WRITTEN PERMISSION.		<b>深圳市步步精科技有限公司</b>	
.X: ±0.38 .XX: ±0.25 .XXX: ±0.13		X*: ±3' X*: ±2' XX*: ±1'	
APPD.	JM_Zheng 23/05'02	NAME: 3.5耳机座 有头 五脚贴片 带柱 四节 (PJ35A046-F05T1BR-B)	
CHKD.	LYX 23/05'02	PJ. NO.: PJ.01.22-01-3001	
DR.	SGF 23/05'02	SIZE: A4   DRW NO.:	
PDWG.NO: 0076-1		FINISH: SEE NOTES   MAT'L.: SEE NOTES	
		SCALE: N/A   REV.: A0   UNIT: mm   PAGE: 1/1	