

REV.	ECN NO.	CONTENT	DATE	ENGINEER
A0			2023 20/04	

- CONTACT CURRENT RATING: 1A.
- CONTACT RESISTANCE: 100 mΩ MAX.;
- INSULATION RESISTANCE: 1000Ω MIN.;
- DIELECTRIC WITHSTANDING: 500V AC MIN.;
- DURABILITY: 5,000 CYCLES MIN.;
- CONNECTOR MATING FORCES: 30N MAX.;
- CONNECTOR UNMATING FORCES: 3N MIN.;

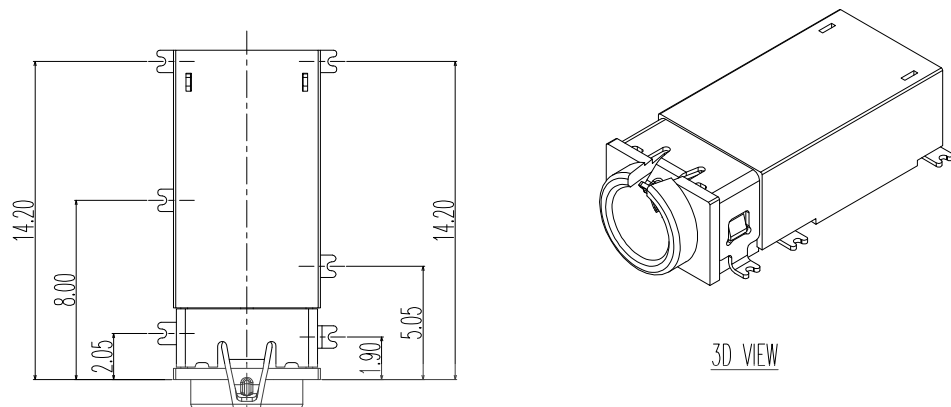

3D VIEW

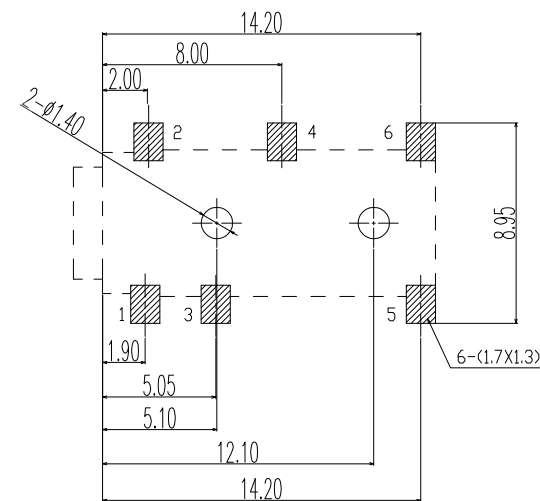

P.C.B LAYOU
TOP VIEW

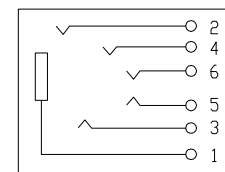

SCHEMATIC

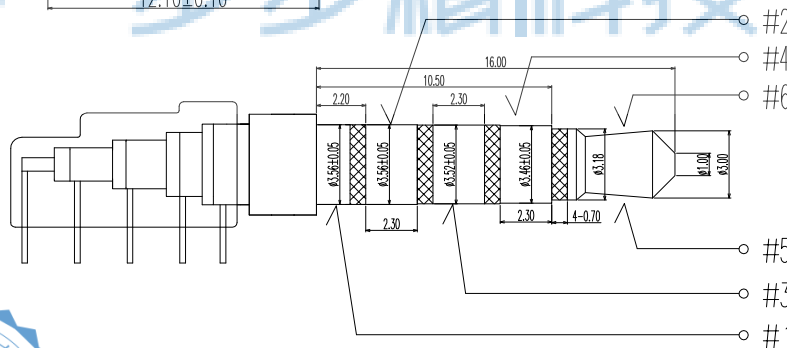
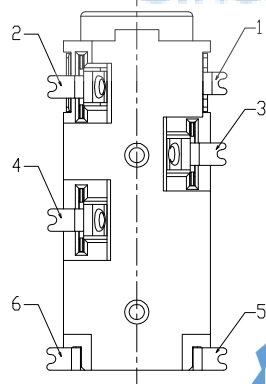
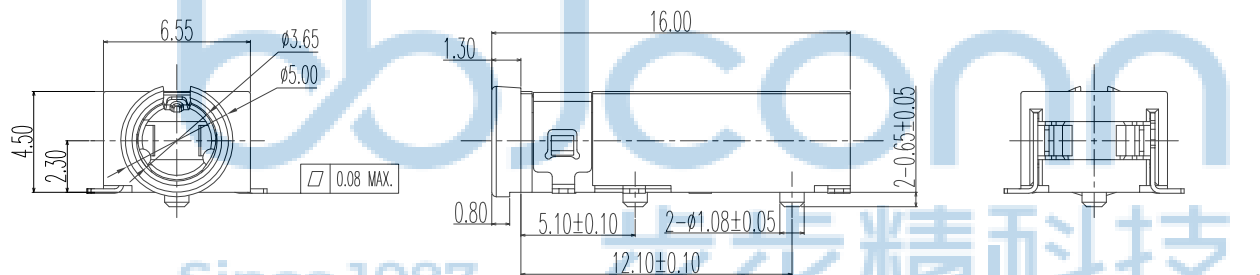

(ø3.50mm 5 POLE PLUG DETAIL DRAWING)



ITEM	NAME	QTY	DESCRIPTION	NOTE
5	HOUSING	1	PART COLOR BLACK	
4	TERMINAL 4#	1	STAINLESS STEEL; NICKEL UNDER PLATING OVERALL; GOLD FLASH PLATING ON SOLDER AREA ;GOLD FLASH PLATING ON CONTACT AREA	T=0.20mm
3	TERMINAL 3#	1	STAINLESS STEEL; NICKEL UNDER PLATING OVERALL; GOLD FLASH PLATING ON SOLDER AREA ;GOLD FLASH PLATING ON CONTACT AREA	T=0.20mm
2	TERMINAL 2#	3	PHOSPHOR BRONZE; NICKEL UNDER PLATING OVERALL; GOLD FLASH PLATING ON SOLDER AREA ;GOLD FLASH PLATING ON CONTACT AREA	T=0.20mm
1	TERMINAL 1#	1	PHOSPHOR BRONZE; NICKEL UNDER PLATING OVERALL; GOLD FLASH PLATING OVERALL;	T=0.20mm

THIS DOCUMENT IS THE SOLE PROPERTY OF BBJconn Technology Co.,Ltd. CORPORATION AND SHOULD NOT BE USED IN WHOLE OR IN PART WITHOUT PRIOR WRITTEN PERMISSION.

深圳市步步精科技有限公司

APPD.	JM_Zheng	23/05/02	NAME:	3.5耳机座 有头 六脚贴 带柱 五节 (PJ35A079-F06J1BR-B)
CHKD.	LYX	23/05/02	PJ. NO.:	PJ.01.22-01-3024
DR.	SGF	23/05/02	SIZE:	A4 DRW NO.:
PDWG.NO:	0076-1		FINISH:	SEE NOTES
			MAT'L.:	SEE NOTES
			SCALE:	N/A
			REV.:	A0
			UNIT:	mm
			PAGE:	1/1

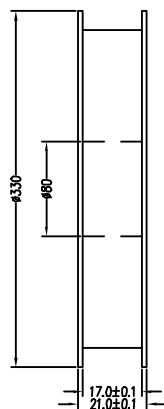
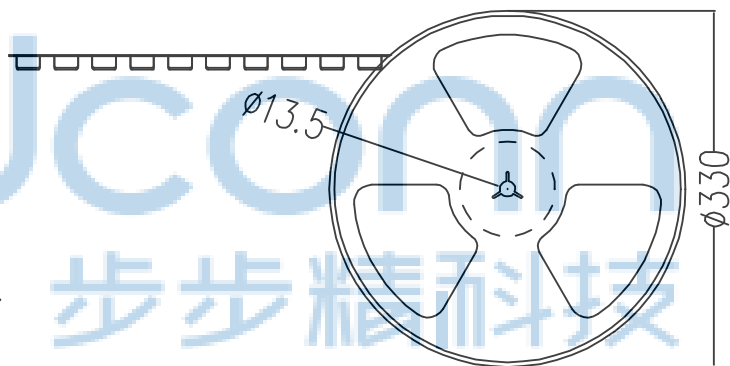
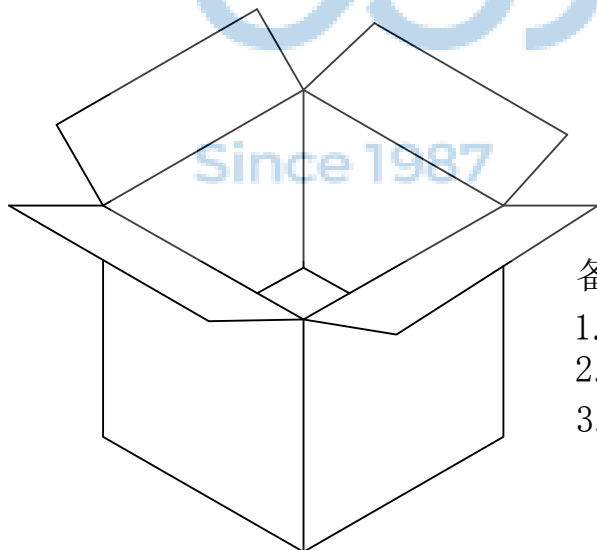
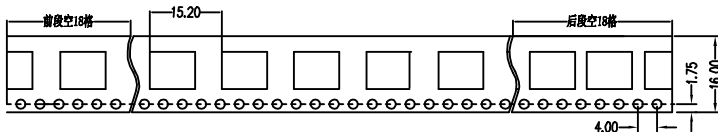
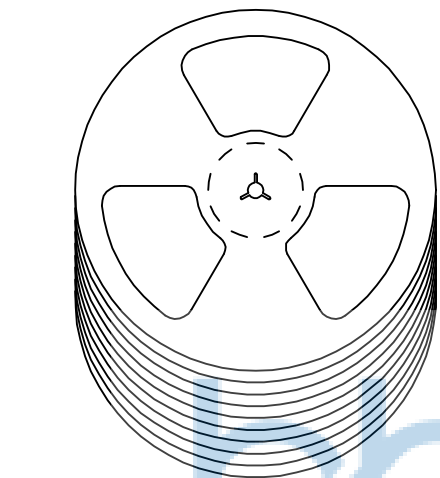

备注:

1. 包装数量: 1000/PCS/卷, 10卷/箱或15卷/箱。
2. 包装袋长度: 每卷前后各空10-20个空格, 中间包装。
3. 材质:
载体: 聚丙烯 (PS), 阻抗 $10^{6-9} \Omega$
上带: 聚乙烯 (PET), 阻抗 $10^{6-11} \Omega$
卷盘: 聚苯乙烯。

纸箱规格: 345*345*23MM

纸箱规格: 345*345*35MM

THIS DOCUMENT IS THE SOLE PROPERTY OF BBJconn Technology Co.,Ltd. Corporation AND SHOULD NOT BE USED IN WHOLE OR IN PART WITHOUT PRIOR WRITTEN PERMISSION.		深圳市步步精科技有限公司 .X: ±0.38 .X': ±3" .XX: ±0.25 .X": ±2" .XXX: ±0.13 .XX': ±1"		NAME: 3.5耳机座 有头 六脚贴 带柱 五节 (PJ35A079-F06J1BR-B) PJ. NO.: PJ.01.22-01-3024 SIZE: A4 DRW NO.: FINISH: SEE NOTES MAT'L.: SEE NOTES SCALE: N/A REV.: A0 UNIT: mm PAGE: 1/1		
PDWG.NO: 0076-1	DR. SGF	23/05'02	APPD. JM_Zheng	23/05'02	CHKD. LYX	23/05'02