

REV.	ECN NO.	CONTENT	DATE	ENGINEER
A0				

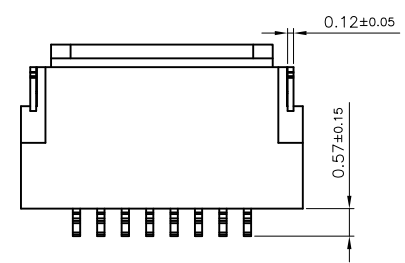

- NOTES:
- MATERIAL:
HOUSING: HIGHT-TEMP PLASTIC, UL 94V-0, COLOR: WHITE;
COVER: HIGHT-TEMP PLASTIC, UL 94V-0, COLOR: BLACK;
CONTACT: COPPER ALLOY;
PEG: COPPER ALLOY;
 - PLATING:
TERMINAL: 50~100u" Nickel UNDERPLATED OVERALL.
S:100~160u" Matte Sn UNDERPLATED OVERALL.
G:1u"Min Au UNDERPLATED CONTACT/SOLDER AREA.
T:3u"Min Au UNDERPLATED CONTACT/SOLDER AREA.
PEG: 50~100u" Nickel UNDERPLATED OVERALL.
100~160u" Matte Sn PLATED ON Nickel OVERALL.
 - RATING:
CURRENT RATING: 0.4A AC/DC
VOLTAGE RATING: 50V AC/DC
TEMPERATURE RANGE: -55° C~+85° C;

PIN NO.	DIM. A	DIM. B	DIM. C	DIM. D
04	3.77	1.50	2.60	3.27
06	4.77	2.50	3.60	4.27
08	5.77	3.50	4.60	5.27
10	6.77	4.50	5.60	6.27
12	7.77	5.50	6.60	7.27
14	8.77	6.50	7.60	8.27
16	9.77	7.50	8.60	9.27
18	10.77	8.50	9.60	10.27
20	11.77	9.50	10.60	11.27
22	12.77	10.50	11.60	12.27
24	13.77	11.50	12.60	13.27
26	14.77	12.50	13.60	14.27
28	15.77	13.50	14.60	15.27
30	16.77	14.50	15.60	16.27
32	17.77	15.50	16.60	17.27
34	18.77	16.50	17.60	18.27
36	19.77	17.50	18.60	19.27
40	21.77	19.50	20.60	21.27
50	26.77	24.50	25.60	26.27

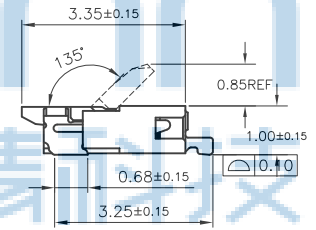
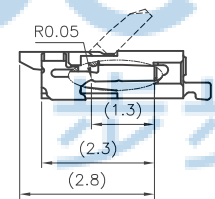
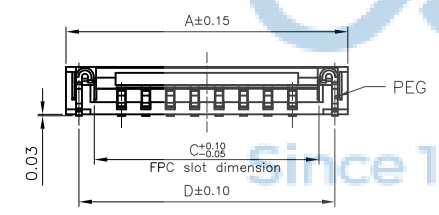
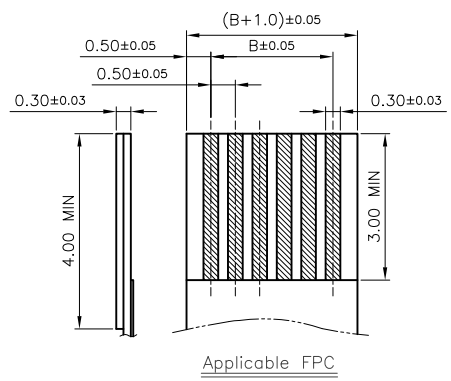
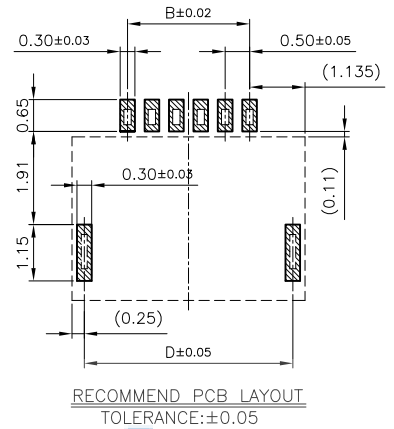
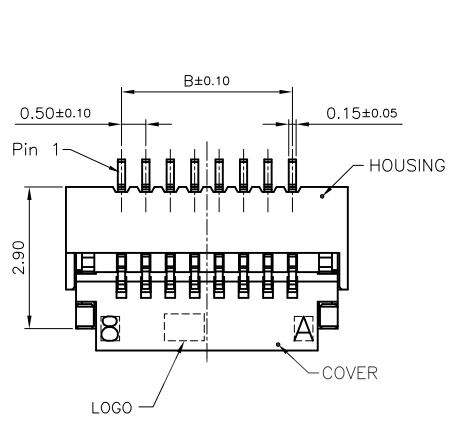

THIS DOCUMENT IS THE SOLE PROPERTY OF BBJconn Technology Co.,Ltd. Corporation AND SHOULD NOT BE USED IN WHOLE OR IN PART WITHOUT PRIOR WRITTEN PERMISSION.

PDWG.NO: 0428-1

DR. SGF

APPD. JM_Zheng

CHKD. LYX

NAME: FPC 0.5-12P 翻盖下接 H=1.0

PJ. NO.: PC.02.04-11-D001

SIZE: A4 DRW NO.:

FINISH: SEE NOTES MAT'L.: SEE NOTES

SCALE: N/A REV.: A0 UNIT: mm PAGE: 1/2

深圳市步步精科技有限公司

REV.	ECN NO	CONTENT	DATE	ENGINEER
A0				

NOTES:

1. ALL DIMENSION MEET EIA-481-3 REQUIREMENTS;
2. CARRRIER MATERIAL: PS, BLACK;
3. PACKING QULITY: 5000PCS/REEL;

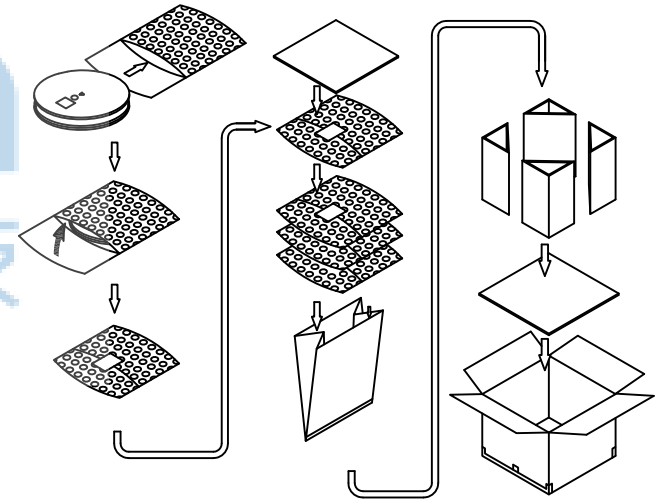
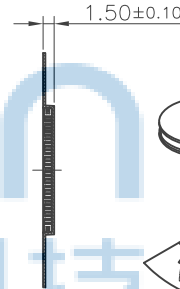
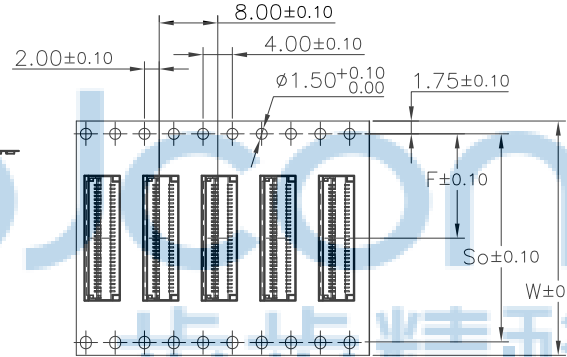
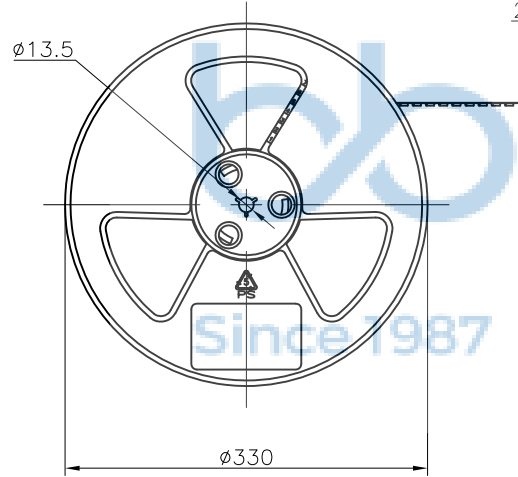
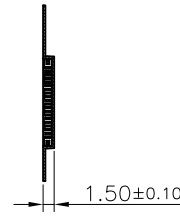
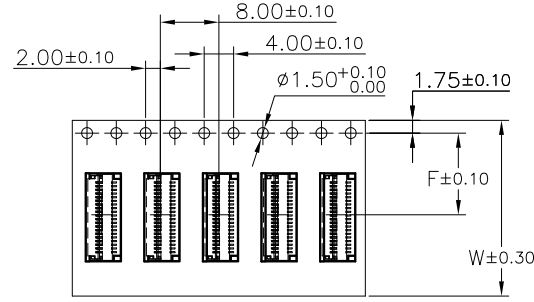
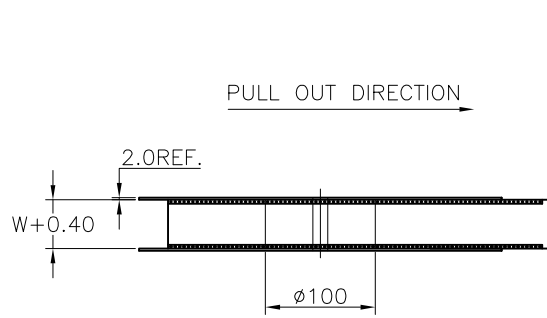

SCALE 3:20

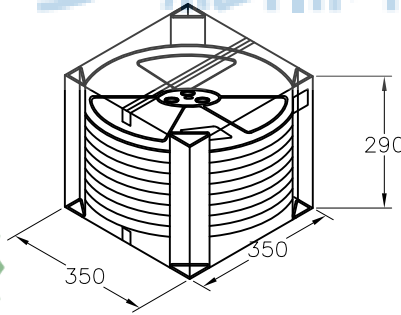

PACKING DISCRPTION:

PIN No.	04~07	08~13	14~30	31~40	41~50	PIN NO	DIM W	DIM F	DIM So
REEL WIDTH	12.4	16.4	24.4	32.4	44.4	04~07	12.0	5.50±0.05	--
PCS/REEL	5000	5000	5000	5000	5000	08~13	16.0	7.50±0.10	--
REEL/BOX	11	9	7	6	5	14~30	24.0	11.50±0.10	--
BOX/PCS	55K	45K	35K	30K	25K	31~40	32.0	14.20±0.10	28.4
CTN. SIZE	350*350*300					41~50	44.0	20.20±0.15	40.4



THIS DOCUMENT IS THE SOLE PROPERTY OF BBJconn Technology Co.,Ltd. Corporation AND SHOULD NOT BE USED IN WHOLE OR IN PART WITHOUT PRIOR WRITTEN PERMISSION.		深圳市步步精科技有限公司 .X: ±0.38 .X': ±3' .XX: ±0.25 .X': ±2' .XXX: ±0.13 .XX': ±1'		NAME: FPC 0.5-12P 翻盖下接 H=1.0	
APPD.	JM_Zheng	PJ. NO.: PC.02.04-11-D001 SIZE: A4 DRW NO.:		FINISH: SEE NOTES MAT'L.: SEE NOTES	
CHKD.	LYX	SCALE: N/A		REV.: A0	UNIT: mm
PDWG.NO:	0428-1	DR.	SGF	PAGE:	2/2