

REV.	ECN NO.	CONTENT	DATE	ENGINEER
A0		Initial release	/	SGF

NOTES:

- VOLTAGE RATING:125 VAC RMS.
- CURRENT RATING:1.5 AMP.
- CONTACT RESISTANCE:40 MILLIOHMS MAX.
- INSULATION RESISTANCE:500 MEGOHMS MIN @ 100V DC .
- DIELECTRIC DIELECTRIC RESISTANCE:100V DC RMS 50Hz. 1MIN.
- DURRABILIT:750 CYCLES MIN.
- MATING/UNMATING FORC:2.24 KG.F MAX.
- ENVIRONMENTAL:  
STORAGE:-40°C~+85°C.  
OPERATION:-40°C~+85°C.

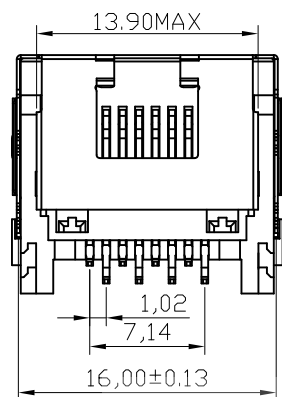

壳子脚

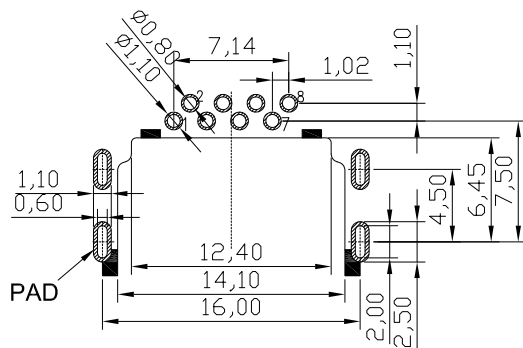

PCBLAOUT T=1.2  
TOL:±0.05

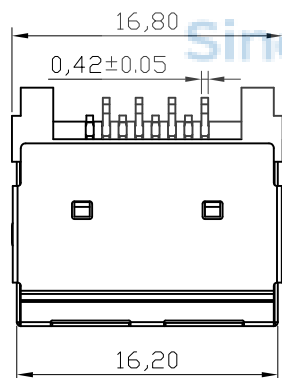
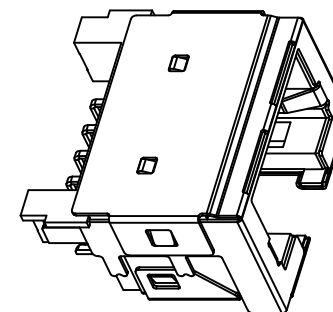
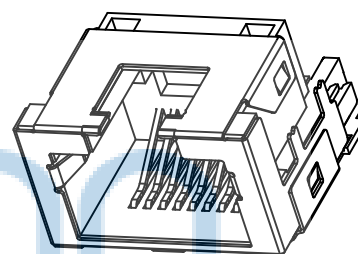
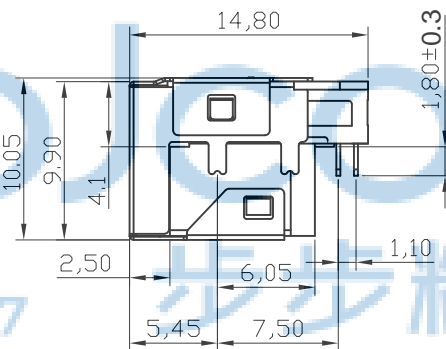
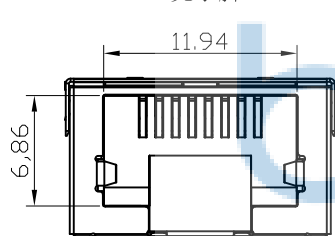

MATERIAL LIST:

3	SHELL	1	BRASS	NI PLATED
2	CONTACT	8	PHOSPHOR BRONZE	AU/SN PLATED
1	HOUSING	1	THERMOPLASTIC (LCP)	(UL 94V-0) BLACK
No.	PART NAME	QTY	MATERIAL	REMARK

THIS DOCUMENT IS THE SOLE PROPERTY OF BBJconn Technology Co.,Ltd. Corporation AND SHOULD NOT BE USED IN WHOLE OR IN PART WITHOUT PRIOR WRITTEN PERMISSION.  
PDWG.NO: 0409-1

**深圳市步步精科技有限公司**

NAME: RJ45 90度 8P 反向沉板4.1 L=14.80 DIP 无弹无灯 平口 铜壳

PJ. NO.: RJ.01.22-11-A001

SIZE: A4 DRW NO.:

FINISH: SEE NOTES MAT'L.: SEE NOTES

SCALE: N/A REV.: A0 UNIT: mm PAGE: 1/2

APPD. JM\_Zheng  
CHKD. LYX  
DR. SGF

REV.	ECN NO	CONTENT	DATE	ENGINEER
A0		Initial release	/	SGF

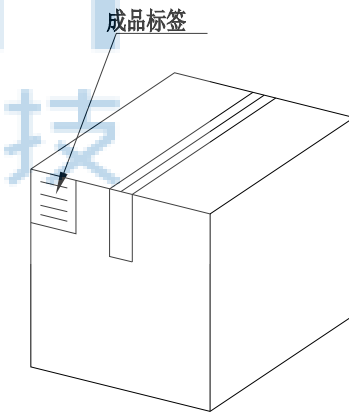
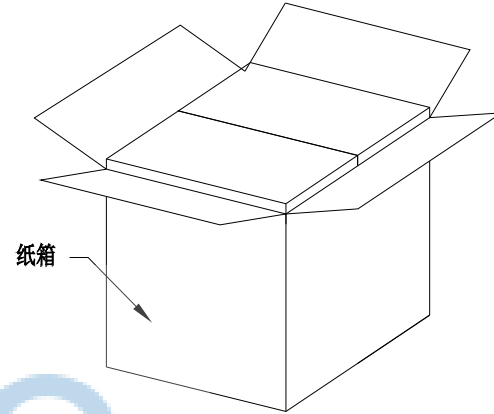
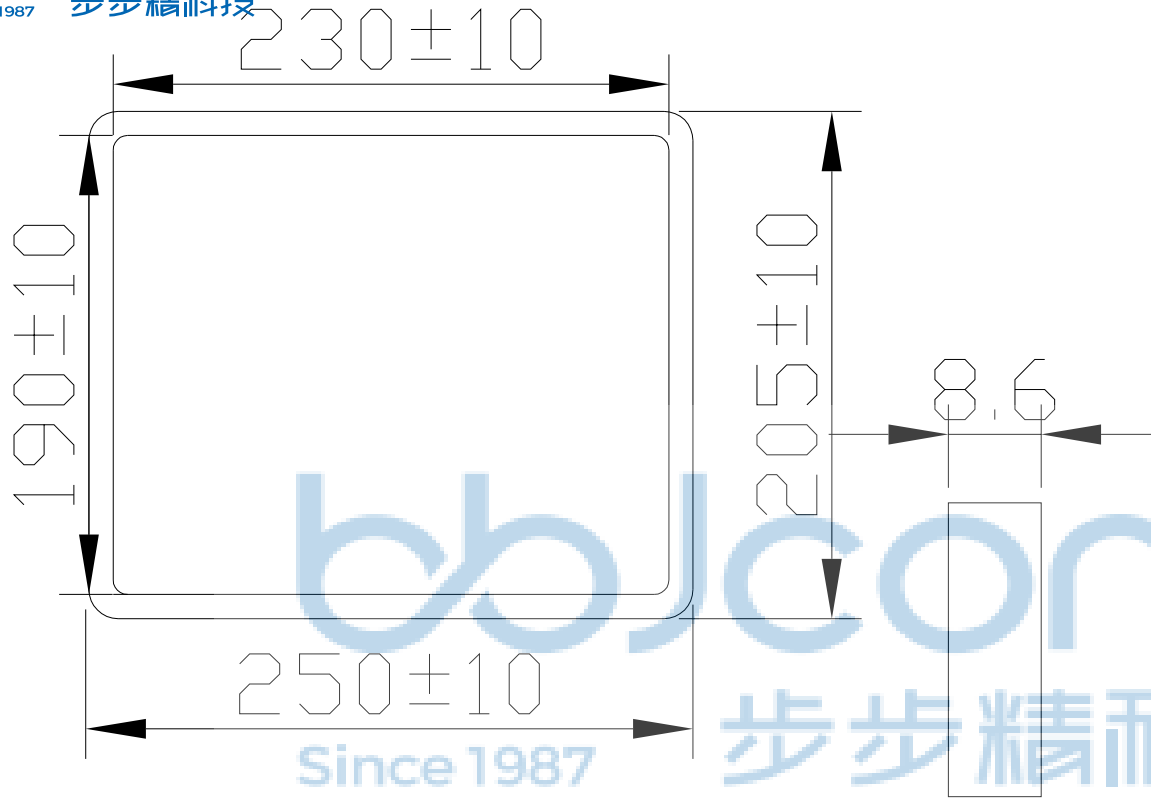

纸箱规格: 350\*210\*290

1. 包装要求:
- 1.1 每盒吸塑盒包装100 pcs;
  - 1.2 每30盘放一箱, 共计3000PCS;
  - 1.3 纸箱外贴上标签

THIS DOCUMENT IS THE SOLE PROPERTY OF BBJconn Technology Co.,Ltd. Corporation AND SHOULD NOT BE USED IN WHOLE OR IN PART WITHOUT PRIOR WRITTEN PERMISSION.		深圳市步步精科技有限公司	
.X: $\pm 0.38$ .XX: $\pm 0.25$ .XXX: $\pm 0.13$		X': $\pm 3'$ .X': $\pm 2'$ .XX': $\pm 1'$	
APPD. JM_Zheng		NAME: RJ45 90度 8P 反向沉板4.1 L=14.80 DIP 无弹无灯 平口 铜壳	
CHKD. LYX		PJ. NO.: RJ.01.22-11-A001	
PDWG.NO: 0409-1		DR. SGF	
		SIZE: A4   DRW NO.:	
		FINISH: SEE NOTES   MAT'L.: SEE NOTES	
		SCALE: N/A   REV.: A0   UNIT: mm   PAGE: 2/2	