

REV	ECN NO	CONTENT	DATE	ENGINEER
A0		INITIAL RELEASE	/	SGF

A

B

C

D

E

A

B

C

D

E

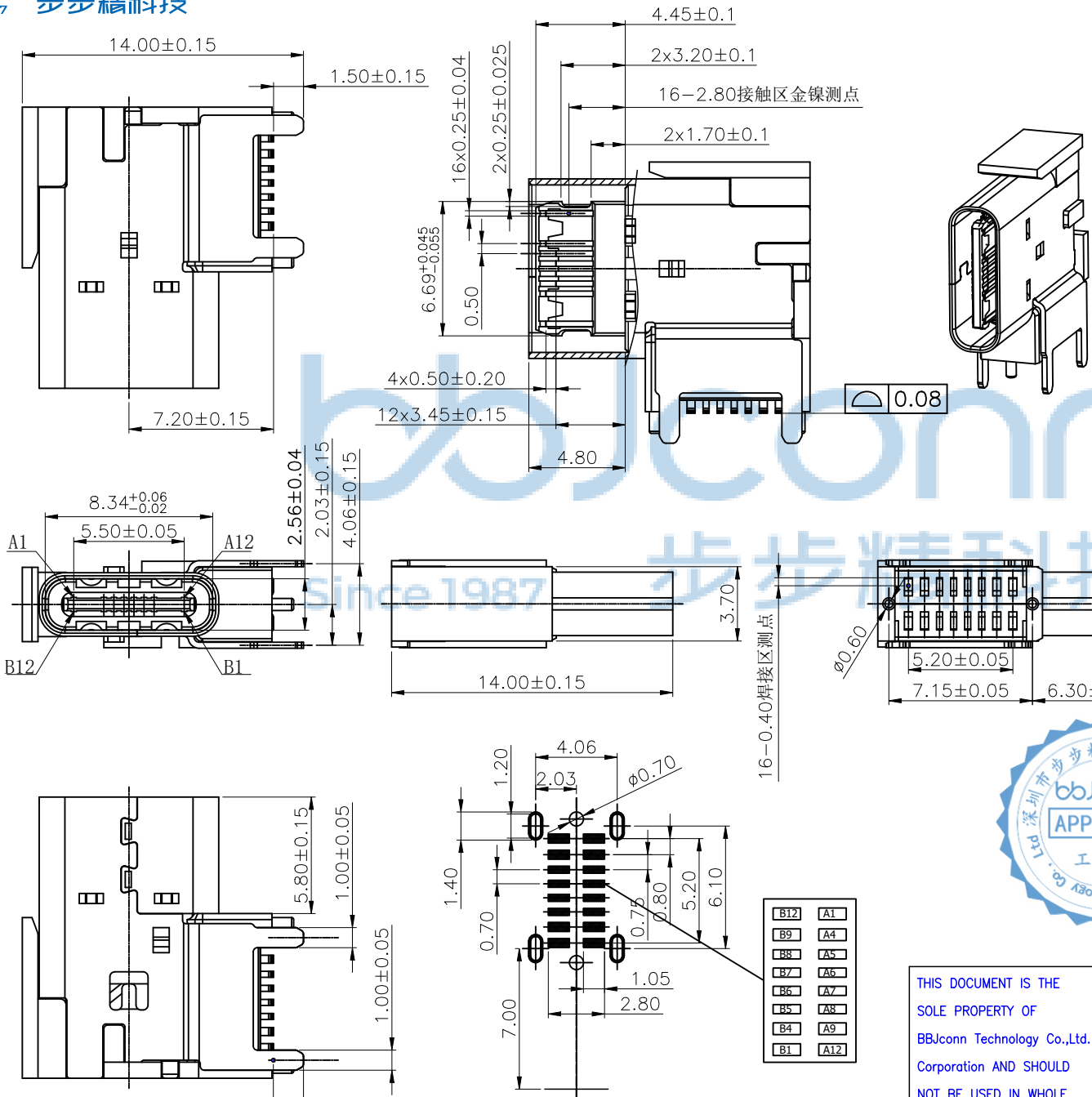

MATERIALS

1. HOUSING : LCP (UL 94V-0), BLACK.
2. TERMINAL : COPPER ALLOY,
GOLD PLATED ON CONTACT AREA.
GOLD FLASH PLATING ON SOLDER TAIL.
NICKEL UNDERPLATED OVER ALL.
3. MID PLATE : STAINLESS STEEL.
4. SHELL : STAINLESS STEEL,NICKEL PLATING.

SPECIFICATION

1. CURRENT RATING : 5.0A FOR Vbus PIN,
1.25A FOR Vconn PIN,
0.25A FOR OTHER PINS.
2. CONTACT RESISTANCE : 40mΩ.
3. INSULATION RESISTANCE : 100MΩ MIN.
4. DIELECTRIC WITHSTANDING VOLTAGE : 100 VAC MIN.
5. OPERATING TEMPERATURE : -40°C TO +85°C.
6. MATING FORCE : 5~20N.
7. UNMATING FORCE : 8~20N.
8. DURABILITY : 10,000 CYCLES.
9. RECOMMENDED PROCESS :
THE PEAK TEMPERATURE ON THE BOARD SHALL
MAINTAIN 260°C.



A1	GND	B12	GND
A2		B11	
A3		B10	
A4	VBUS	B9	VBUS
A5	CC1	B8	SBU2
A6	D+	B7	D-
A7	D-	B6	D+
A8	SBU1	B5	CC2
A9	VBUS	B4	VBUS
A10		B3	
A11		B2	
A12	GND	B1	GND

B12	A1
B9	A4
B8	A5
B7	A6
B6	A7
B5	A8
B4	A9
B1	A12

RECOMMENDED P.C.B LAYOUT
TOLERANCE ± 0.05mm (TOP VIEW)

THIS DOCUMENT IS THE
SOLE PROPERTY OF
BBJconn Technology Co.,Ltd.
Corporation AND SHOULD
NOT BE USED IN WHOLE
PRIOR WRITTEN PERMISSION.

bbJconn 深圳市步步精科技有限公司

APPD	JM_Zheng	NAME:TYPE-C 16P 母座 侧插 四脚插 端子SMT 带中夹 片 L=14.0 CH=7.20 不锈钢外壳 LCP黑胶 编带
CHKD	LYX	PJ NO: 126-227-160001-N5G
DR	SGF	SIZE:A4 DRW NO:
		FINISH:SEE NOTES MAT'L:SEE NOTES
		SCALE:N/A REV:A0 UNIT:mm PAGE:1/2

REV	ECN NO	CONTENT	DATE	ENGINEER
AO		INITIAL RELEASE	/	SGF

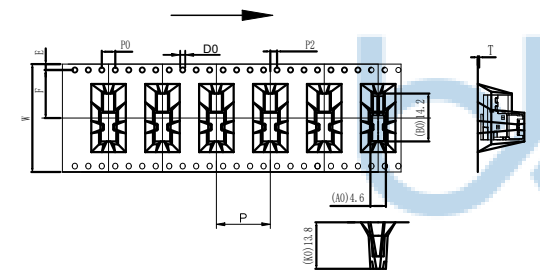
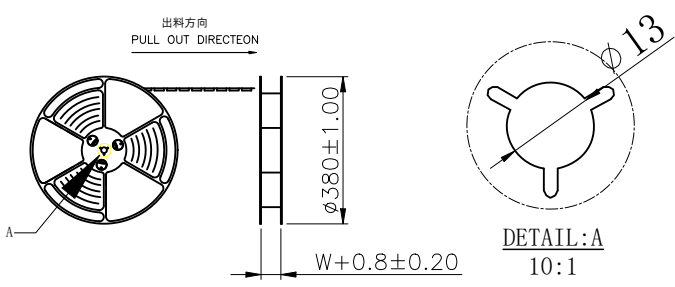

NOTES

1. 带子引导长度
出料方向

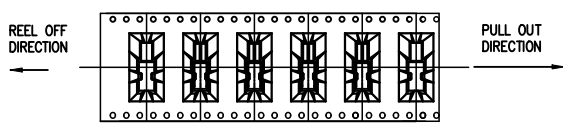
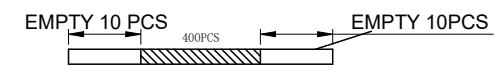

2. 上带剥离力为: 0.1~1.3N(10.2gf~130gf)
出货运输过程中一定注意:
卷带在运输过程中不能散开

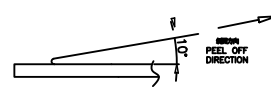

W	32±0.3
F	14.2±0.1
SO	±0.1
T	0.50±0.1
E	1.75±0.1
P	16.0±0.1
P0	4±0.1
P2	2±0.15
A0	4.60±0.1
B0	14.2±0.1
K0	13.8±0.1
DO	1.50 ^{+0.1} _{-0.1}



卷带	规格: $\phi 380\text{mm}$	包装数量: 400PCS
纸箱	规格: 390mmX390mmX320mm	包装数量: 8盘 / 3200PCS

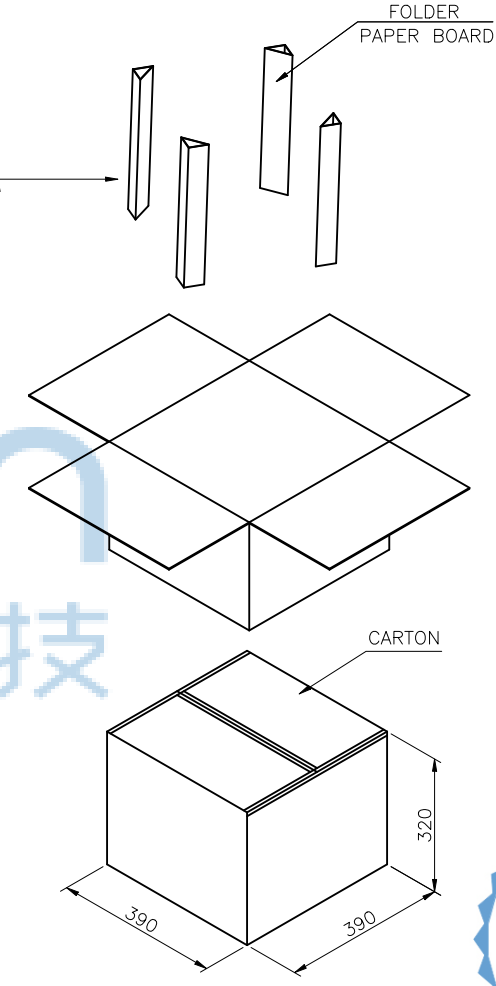
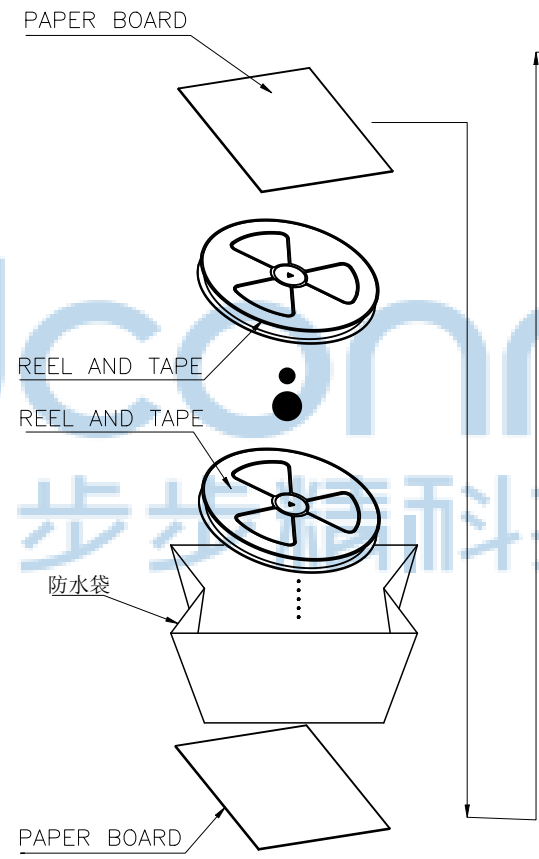

THIS DOCUMENT IS THE SOLE PROPERTY OF BBJconn Technology Co.,Ltd. Corporation AND SHOULD NOT BE USED IN WHOLE PRIOR WRITTEN PERMISSION.

PDWG NO: 0366-2

DR SGF

深圳市步步精科技有限公司

NAME: TYPE-C 16P 母座 侧插 四脚插 端子SMT 带中夹 片 L=14.0 CH=7.20 不锈钢外壳 LCP黑胶 编带

PJ NO: 126-227-160001-N5G

SIZE:A4 DRW NO:

FINISH:SEE NOTES MAT'L:SEE NOTES

SCALE:N/A REV:AO UNIT:mm PAGE:2/2