

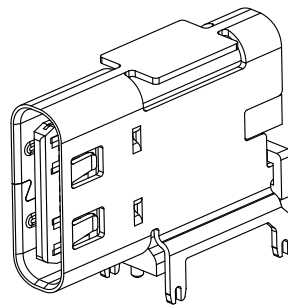

REV	ECN NO	CONTENT	DATE	ENGINEER
A0		INITIAL RELEASE	/	SGF

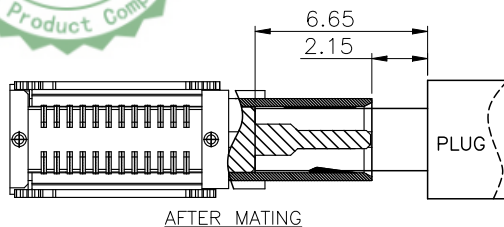
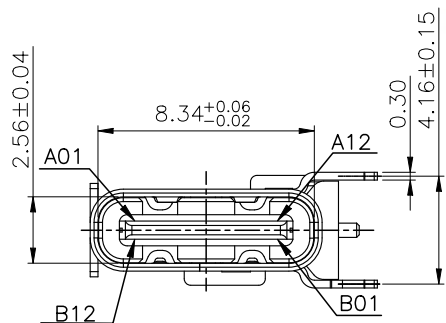

3D VIEW

SPECIFICATION:

一、 ELECTRICAL:

- 1.CURRENT RATING:5A;
- 2.CONTACT RESISTANCE:40mΩ Max;
- 3.DIELECTRIC WITHSTANDING VOLTAGE:100V AC;
- 4.INSULATION RESISTANCE:100 MΩ MIN;

二、 MECHANICAL;

- 1.MATING FORCE:5~20N;
- 2.UNMATING FORCE:8~20N;
- 3.DURABILITY:10000 CYCLES;6~20N AFTER DURABILITY TEST;

三、 MATERIAL:

- 1.HOUSING&MOLDING:LCP UL94V-0;
- 2.TERMINAL:C18400 T=0.15mm;
- 3.SHELL:SUS304 T=0.30mm;
- 4.MID PLATE:SUS301 T=0.15mm;

四、 PLATING SPECIFICATION:

- 1.TERMINAL:CONTACT POINT GOLD PLATED 3u"Min
PIN WELDING AREA GOLD PLATED 1u" Min.
- 2.NI 40u" Min. UNDER PLATED OVER ALL.
- 3.SHELL:PLATED Ni 50u" Min(Salt spray 48H)

五、 ELECTROPLATED PRODUCTS NEED TO UNDERGO TIN ADHESION TESTING: THE TIN ADHESION AREA SHOULD REACH OVER 95%.

六、 SMT REFLOW SOLDERING (PEAK VALUE 260 °C ± 5 ° C) SHALL BE FREE OF BLISTERING, GLUE MELTING AND POOR COLOR CHANGE (DEFORMATION WITHIN TOLERANCE)

七、 OPERATING TEMPERATURE: -40°C~+85°C

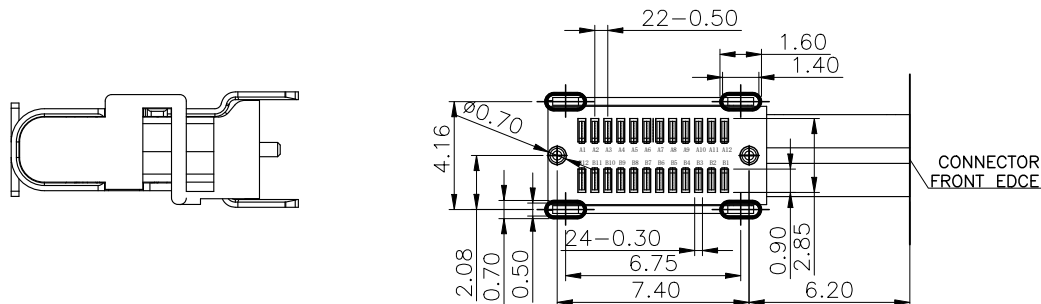
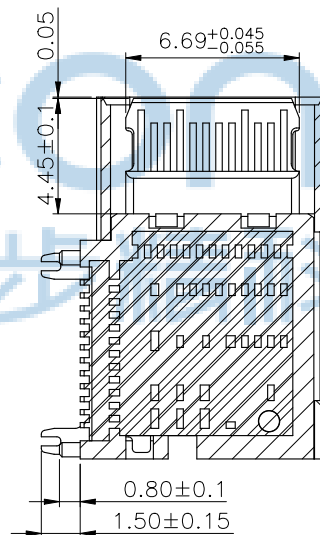
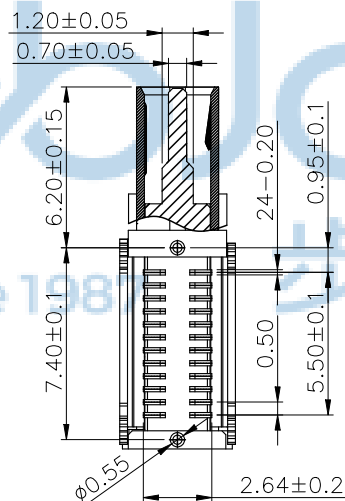
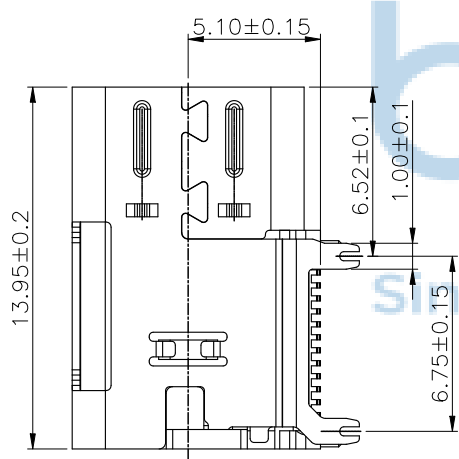

RECOMMENDED P.C.B. LAYOUT (T:1.00mm)
TOLERANCE UNSPECIFIED ±0.05mm



A1	GND	B12	GND
A2	TX1+	B11	RX1+
A3	TX1-	B10	RX1-
A4	VBUS	B9	VBUS
A5	CC1	B8	SBU2
A6	D+	B7	D-
A7	D-	B6	D+
A8	SBU1	B5	CC2
A9	VBUS	B4	VBUS
A10	RX2-	B3	TX2-
A11	RX2+	B2	TX2+
A12	GND	B1	GND
PIN	SIGNAL NAME	PIN	SIGNAL NAME

THIS DOCUMENT IS THE
SOLE PROPERTY OF
BBJconn Technology Co.,Ltd.
Corporation AND SHOULD
NOT BE USED IN WHOLE
PRIOR WRITTEN PERMISSION.

深圳市步步精科技有限公司

.X: ±0.38 X': ±3'
.XX: ±0.25 .X': ±2'
.XXX: ±0.13 .XX': ±1'

NAME: TYPE-C 24P 母座 侧插 四脚插 鱼叉脚
端子SMT 带柱 L=13.95 CH=5.1 编带

APPD	JM_Zheng
CHKD	LYX
DR	SGF

PJ NO: 126-227-240001-N5G	
SIZE:A4	DRW NO:
FINISH:SEE NOTES	MAT'L:SEE NOTES
SCALE:N/A	REV:A0
UNIT:mm	PAGE:1/2

PDWG NO: 0366-2

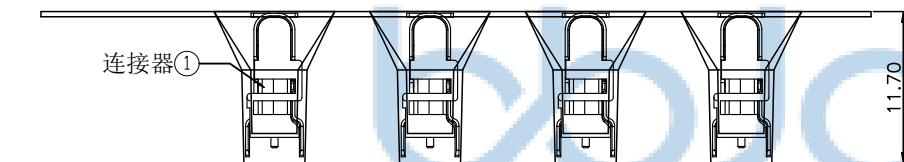
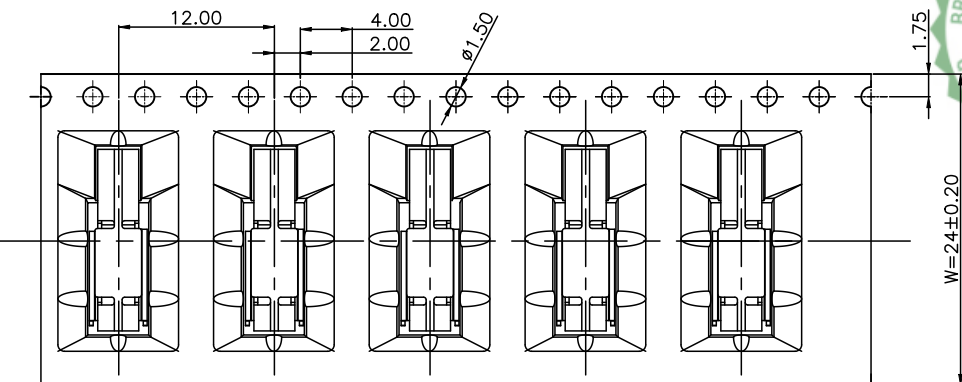

产品入载带示意图

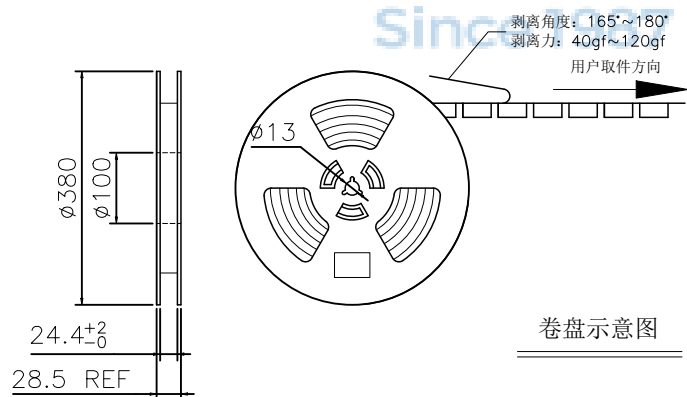

卷盘示意图



包装示意图

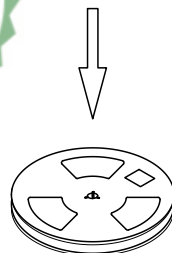

卷盘④

卷盘贴标签示意图

技术要求:

1. 载带首尾各留出10PCS空格不装产品;
2. 每穴放置1PCS产品, 每卷装650PCS产品, 放置方式如图所示;
3. 将包装好的产品;每盘必需贴上内标签;将贴好内标签的产品每10盘堆叠.
4. 在纸箱四角垫上4个三角垫, 然后把装好产品的卷盘放入纸箱中, 最后用胶带封箱;
(如客户有要求, 请按客户要求包装出货)
5. 上带与载带的剥离力: 40gf~120gf, 跳动量在30gf内;
(剥离角度: 165°~180°, 剥离速度: 250~300mm/min)
6. 产品符合RoHS环保标准要求.

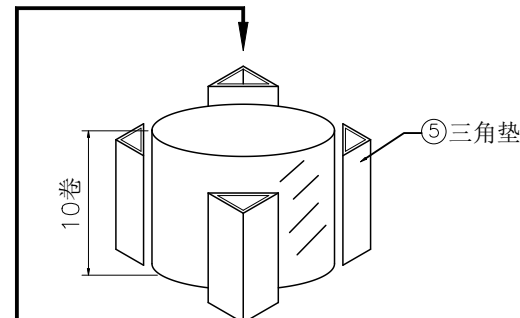

10盘产品叠层示意图

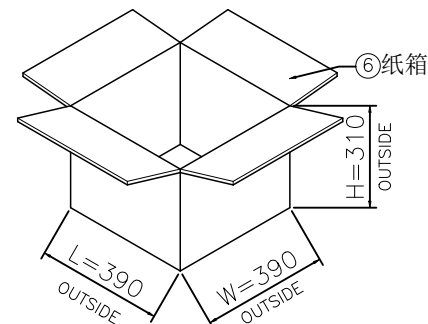

06	纸箱	390mm*390mm*310mm	1 PCS
05	三角垫	300mm*260mm*7mm	4 PCS
04	卷盘	D=380mm, d=100mm, H=28.5mm	10 PCS
03	上带	W=20.70mm, T=0.05mm	8040 mm
02	载带	W=24mm, T=0.50mm, P=12.0mm	8040 mm
01	连接器	24PIN, SMT	6500 PCS
序号	物料名称	规格	描述

THIS DOCUMENT IS THE
SOLE PROPERTY OF
BBJconn Technology Co.,Ltd.
Corporation AND SHOULD
NOT BE USED IN WHOLE
PRIOR WRITTEN PERMISSION.
PDWG NO: 0366-2

深圳市步步精科技有限公司

.X: ±0.38 X': ±3'
.XX: ±0.25 .X': ±2'
.XXX: ±0.13 .XX': ±1'

NAME: TYPE-C 24P 母座 侧插 四脚插 鱼叉脚
端子SMT 带柱 L=13.95 CH=5.1 编带

APPD JM_Zheng

PJ NO: 126-227-240001-N5G

CHKD LYX

SIZE:A4 DRW NO:

DR SGF

FINISH:SEE NOTES MAT'L:SEE NOTES
SCALE:N/A REV:AO UNIT:mm PAGE:2/2