

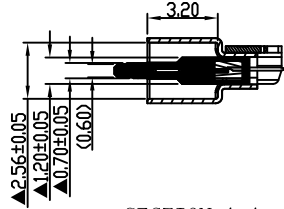

REV.	DESCRIPTION	NAME	DATE
A	NEWS ISSUE		

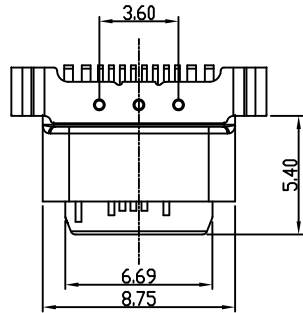

SECTION A-A
SCALE: 1:1

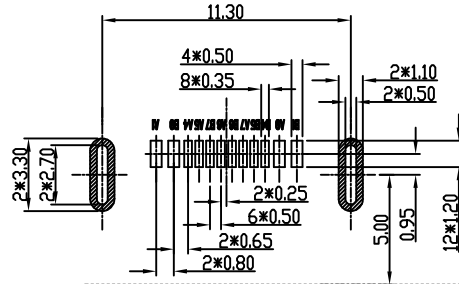

PRODUCT EDGE

RECOMMENDED PCB LAYOUT(TOP VIEW)
THICKNESS 0.8 ± 0.10MM; DEFAULT TOLERANCE: ± 0.05

NOTES:

1.MATERIAL:

- 1.1 HOUSING:SEE TABLE ORDERING INFORMATION
- 1.2 CONTACTS:Copper Alloy(C7025)
- 1.3 SHELL:Stainless steel

2.ELECTRICAL CHARACTERISTICS:

- 2.1 CONTACT RESISTANCE:40mΩ Max FOR INTIAL.10mΩ CHANGE AFTER TEST. MEASURE at 20mv, 100mA.
- 2.2 CONTACT CURRENT RATING:3A FOR VBUS PIN;1.25A FOR VCONN and GND PIN;0.25A FOR all THE OTHER PIN.
- 2.3 CLTAGE RATING:30V
- 2.4 DIELECTRIC WITHSTANDING VOLTAGE:100 V R.M.S.
- 2.5 INSULATION RESISTANCE 100 MEGOHMS MIN

3.MECHANICAL PERFORMANCE:

- 3.1 INSERT FORCE:0.51-2.04Kg
- 3.2 EXTRACT FORCE:0.82-2.04Kg
- 3.3 AFTER DURABILITY:0.61-2.04Kg
- 3.4 DURABILITY:10000 CYCLES

4.EVIRONMENTAL:

- 4.1 OPERATION TEMPERATURE : -20°C to +85°C

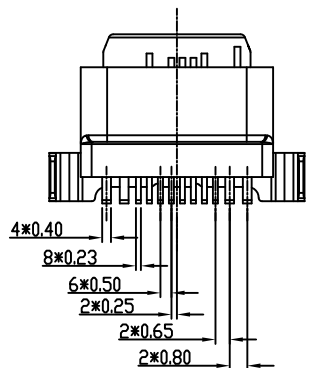
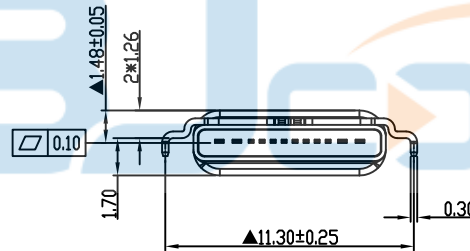
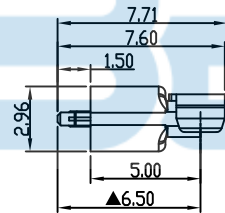
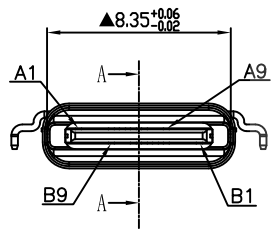

5	中间片	1PCS	SUS304-1/2H	T=0.15mm, 素材
4	护套壳子	1PCS	SUS304-1/2H	T=0.30mm 镀镍, 盐雾48H最小
3	MODING弹子	2PCS	LCP/C7025	LCP黑色, 半金雾锡1U"
2	端子	2PCS	C7025	T=0.15mm 镀半金镍1U"
1	拉伸壳子	1PCS	SUS316L	T=0.20mm 镀镍
NO.	Part Name	QTY	Material	Remark

TOLERANCE UNSPECIFIED		.0 ±0.35		深圳市步步精科技有限公司 TITLE: TYPE-C 12P 母座 L=7.60 沉板1.70 两脚外漏1.5mm 端子SMT	
		.00 ±0.25			
		.000 ±0.15			
		X. ° ±2.00°			
CUSTOMER DRAWING					
DRAWN/ DATE	设计 TSP	SIZE:A4	UNIT:MM.	PART. NO:	126-221-120002-J2G
CHECKED/ DATE	审核 LYX	SCALE: 1:1	PROJECTION	REV.: 版本	
APPROVED/ DATE	核准 LJP	DWG. PATH		0395-1	SHEET: 页码

A12	A11	A10	A9	A8	A7	A6	A5	A4	A3	A2	A1
			VBUS	D-	D+	Vconn	VBUS				GND
GND			VBUS	Vconn	D+	D-		VBUS			
B1	B2	B3	B4	B5	B6	B7	B8	B9	B10	B11	B12



REV.	DESCRIPTION	NAME	DATE
A	NEWS ISSUE		

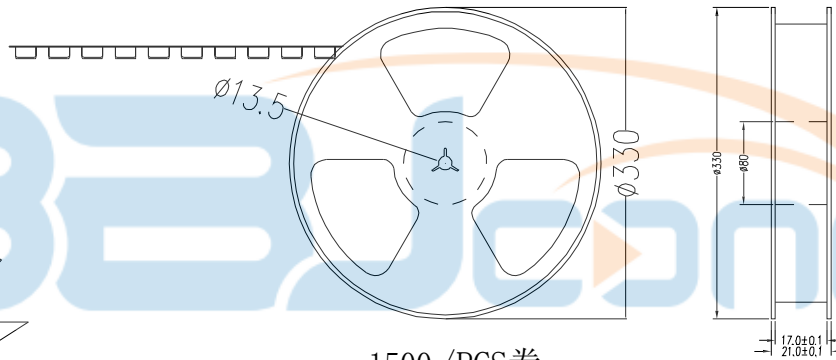
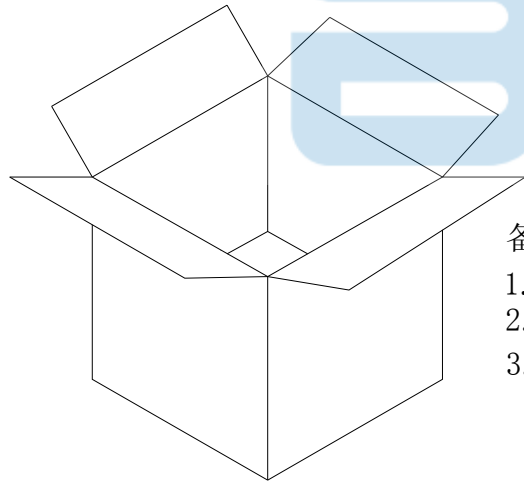
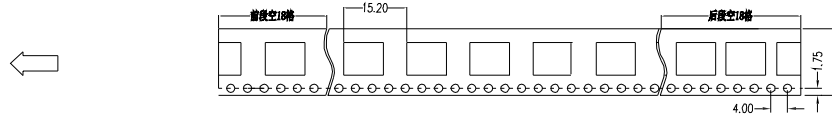
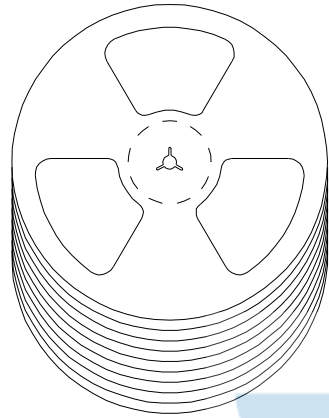

1500 / PCS 卷

备注:

1. 包装数量: 1500 / PCS / 卷, 10卷 / 箱或15卷 / 箱。
2. 包装袋长度: 每卷前后各空10-20个空格, 中间包装。
3. 材质:
 载体: 聚丙烯 (PS), 阻抗 $10^{6-9} \Omega$
 上带: 聚乙烯 (PET), 阻抗 $10^{6-11} \Omega$
 卷盘: 聚苯乙烯。

纸箱规格: 345*345*230MM

TOLERANCE UNSPECIFIED		深圳市步步精科技有限公司 TITLE: TYPE-C 12P 母座 L=7.60 沉板1.70 两脚外漏1.5mm 端子SMT	
.0	±0.35		
.00	±0.25	DRAWN/ DATE 设计 TSP SIZE:A4 UNIT:MM. PART. NO: 126-221-120002-J2G	
.000	±0.15	CHECKED/ DATE 审核 LYX SCALE: 1:1 PROJECTION REV.: 版本	
X.°	±2.00°	APPROVED/ DATE 核准 LJP DWG. PATH 0395-1 SHEET: 页码	
CUSTOMER DRAWING			