

REV.	ECN NO	CONTENT	DATE	ENGINEER
A0		Initial release	/	TSP

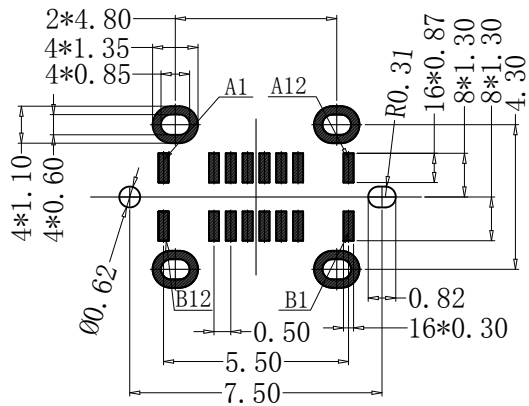
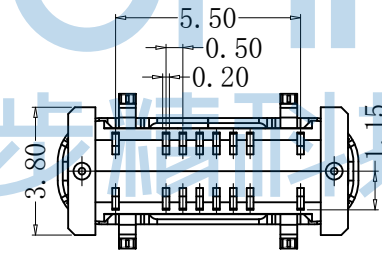
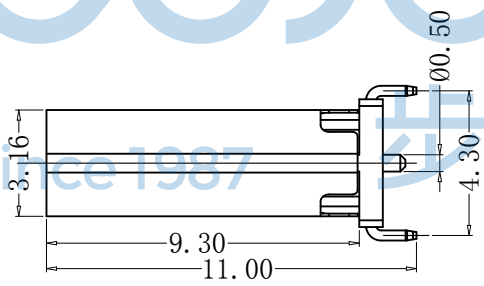
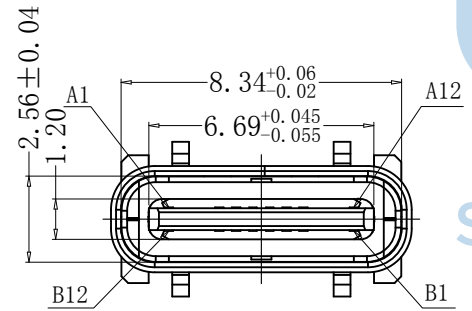
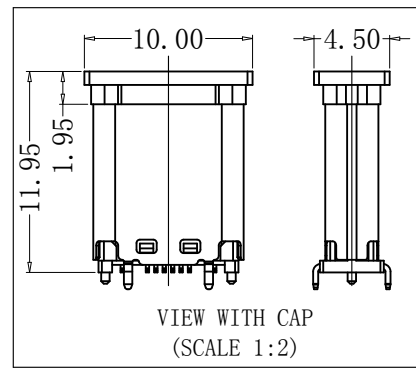
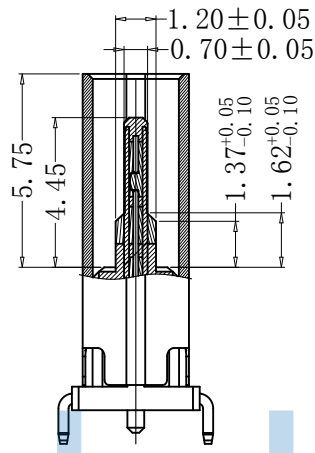
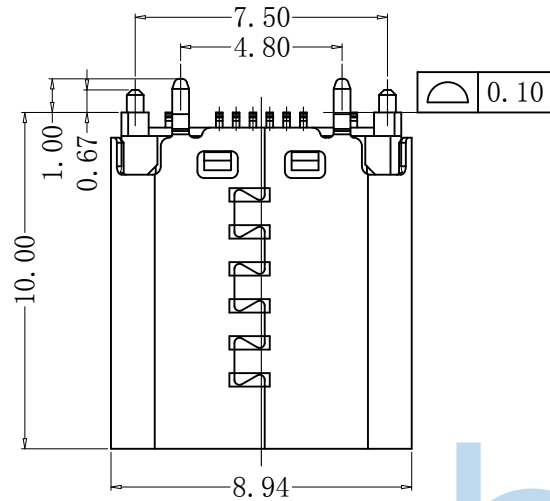

(TOP VIEW)
RECOMMENDED P. C. B. LAYOUT (T:0.8mm)
TOLERANCE UNSPECIFIED ±0.05mm

PIN DEFINE TABLE			
PIN	SIGNAL	PIN	SIGNAL
A12	GND	B1	GND
A11	—	B2	—
A10	—	B3	—
A9	VBUS	B4	VBUS
A8	SBU1	B5	CC2
A7	D-	B6	D+
A6	D+	B7	D-
A5	CC1	B8	SBU2
A4	VBUS	B9	VBUS
A3	—	B10	—
A2	—	B11	—
A1	GND	B12	GND

SPECIFICATION:

- MATERIAL & FINISH:SEE THE LIST;
- PLATING SPECIFICATION:
 - CONTACTS:
 - Ni 50u" MIN. UNDER PLATED OVER ALL.
 - Au PLATED ON THE MATING AREA OF CONTACT.
 - Au PLATED ON THE SOLDER AREA.
 - SHELL: Ni 30u" MIN. UNDER PLATED OVER ALL.
 - MID PLATE: CLEAR ONLY
- MECHANICAL:
 - MATING FORCE: 0.5~2.0kgf;
 - UNMATING FORCE: 0.8~2.0kgf.
 - DURABILITY: 10000 CYCLES;
- ELECTRICAL:
 - CURRENT RATING: 5A Max;
 - VOLTAGE RATING: 20V Max;
 - DIELECTRIC WITHSTANDING VOLTAGE: 100VAc;
 - CONTACT RESISTANCE: 40mΩ Ohms Max.;
 - INSULATION RESISTANCE: 100M Ohms Min.;
- ENVIRONMENTAL:
 - OPERATING TEMPERATURE: -40° C~+85° C;
 - WETTING TEMPERATURE: 265±5° C, 5±0.5s
 - Salt Spray Test: 48H Min



NO.	PART NAME	Q' TY	MATERIAL	FINISH
5	CAP	1	High temperature plastic	UL94 V-0, Black
4	Shell	1	Stainless Steel, T=0.30mm	30u"Ni Min.
3	GroundBar	1	Stainless Steel, T=0.15mm	No Plating
2	Contact	16	Copper Alloy, T=0.15mm	Au/Ni-Plated
1	Housing	1	High temperature plastic	UL94 V-0, Black

THIS DOCUMENT IS THE SOLE PROPERTY OF BBJconn Technology Co.,Ltd. CORPORATION AND SHOULD NOT BE USED IN WHOLE OR IN PART WITHOUT PRIOR WRITTEN PERMISSION.
PDWG.NO: 0804-1

深圳市步步精科技有限公司

NAME: TYPE-C 16P 母座 直立式 四脚插 带柱 端子SMT H=10.0

APPD. JM_Zheng PJ. NO.: 126-224-160008-J8G

CHKD. LYX SIZE: A4 DRW NO.:

DR. TSP FINISH: SEE NOTES MAT'L.: SEE NOTES

SCALE: N/A REV.: A0 UNIT: mm PAGE: 1/2

REV.	ECN NO	CONTENT	DATE	ENGINEER
A0		Initial release	/	TSP

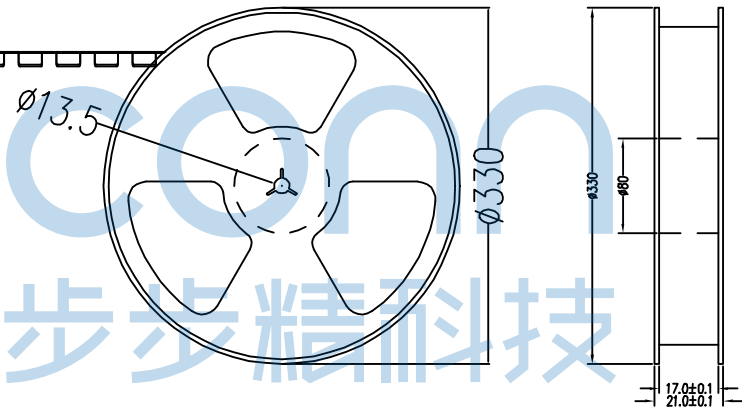
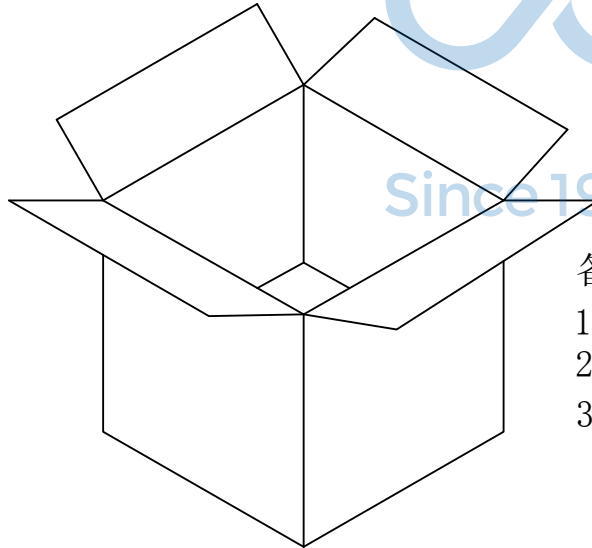
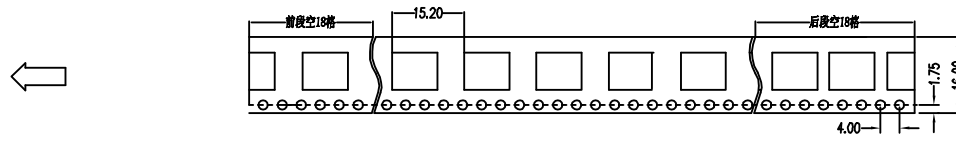
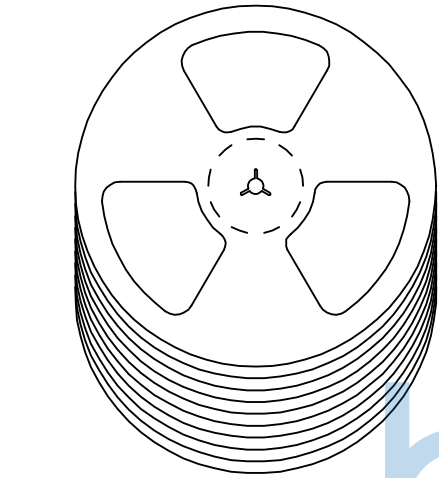

备注:

1. 包装数量: 250/PCS/卷, 10卷/箱。
2. 包装袋长度: 每卷前后各空10-20个空格, 中间包装。
3. 材质:
载体: 聚丙烯 (PS),
上带: 聚乙烯 (PET),
卷盘: 聚苯乙烯。

纸箱规格: 345*345*23MM
纸箱规格: 345*345*35MM

THIS DOCUMENT IS THE SOLE PROPERTY OF BBJconn Technology Co.,Ltd. Corporation AND SHOULD NOT BE USED IN WHOLE OR IN PART WITHOUT PRIOR WRITTEN PERMISSION.		深圳市步步精科技有限公司	
.X: ±0.38 .XX: ±0.25 .XXX: ±0.13		X': ±3" .X': ±2" .XX': ±1"	
APPD.	JM_Zheng	NAME: TYPE-C 16P 母座 直立式 四脚插 带柱 端子SMT H=10.0	
CHKD.	LYX	PJ. NO.: 126-224-160008-J8G	
DR.	TSP	SIZE: A4 DRW NO.:	
PDWG.NO: 0804-1		FINISH: SEE NOTES MAT'L.: SEE NOTES	
		SCALE: N/A REV.: A0 UNIT: mm PAGE: 2/2	