

| REV. | ECN NO | CONTENT | DATE | ENGINEER |
|------|--------|-----------------|------|----------|
| A0 | | Initial release | / | TSP |

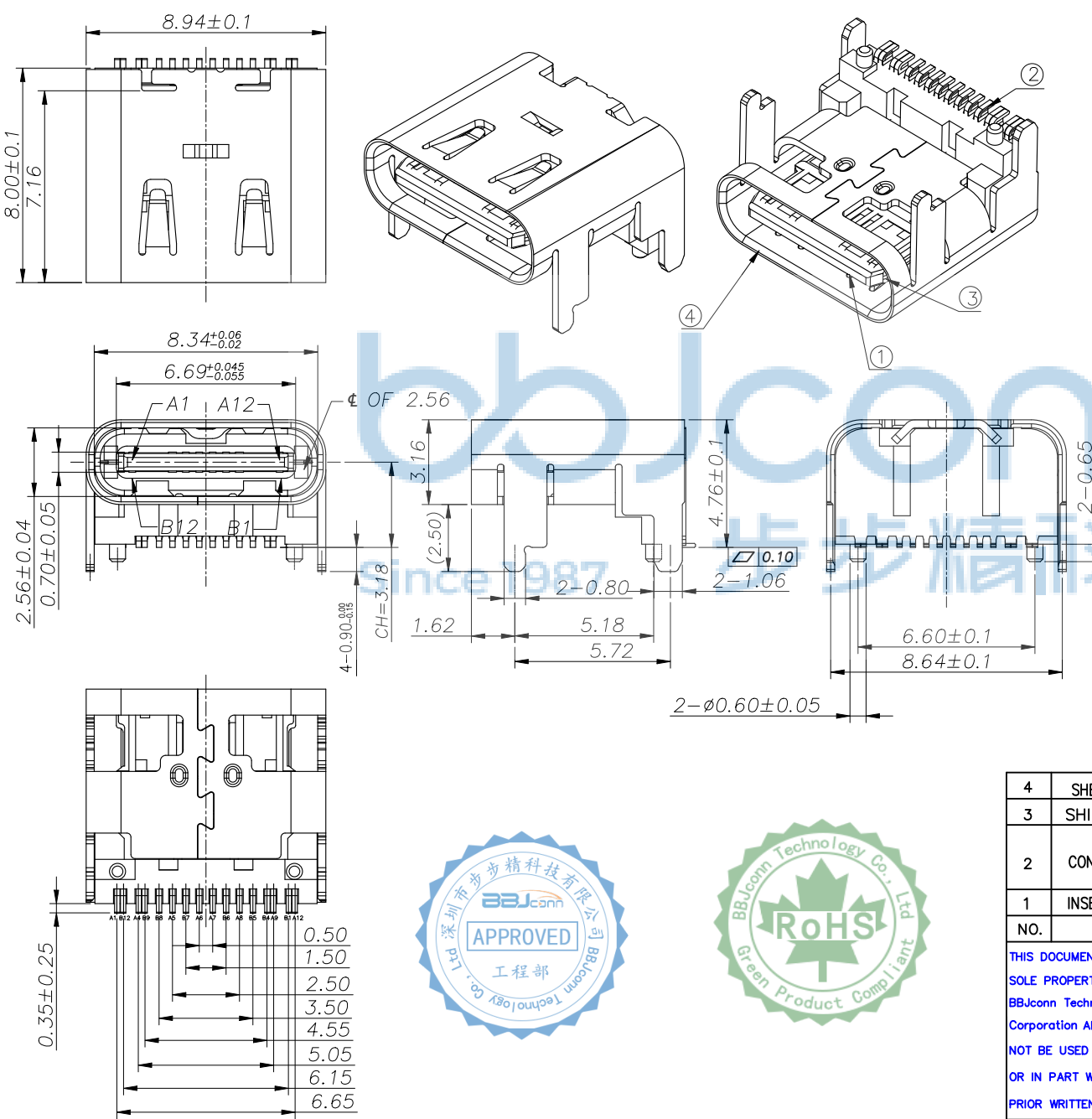

NOTE:

1. MATERIAL SPECIFICATION:
 1. HOUSING: HIGH TEMPERATURE RESISTANT PLASTIC, UL94 V-0.
 2. CONTACTS: COPPER ALLOY
 3. MID PLATE: STAINLESS STEEL
 4. SHELL: STAINLESS STEEL
2. PLATING SPECIFICATION:
 - 2-1. CONTACTS:
 - Ni 50u" MIN. UNDER PLATED OVER ALL.
 - Au PLATED ON THE FUNCTIONAL AREA OF CONTACT.
 - (GOLD PLATING THICKNESS FOLLOW THE P/N)
 - GOLD FLASH PLATING ON SOLDER AREA
 - 2-2 SHELL OR OUTSIDE SHELL:
 - Ni 30u" MIN. UNDER PLATED OVER ALL.
3. MECHANICAL PERFORMANCE,
 - 3-1. INSERTION FORCE: 0.5~2.0kgf.
 - 3-2. REMOVAL FORCE: 0.8kgf~2.0kgf.
 - 3-3. DURABILITY: 10000 CYCLES.
4. ELECTRICAL PERFORMANCE,
 - 4-1. CURRENT RATING: 5A
VOLTAGE RATING: 20V
 - 4-2. INSULATION RESISTANCE: 100MΩ MIN
 - 4-3. DIELECTRIC WITHSTAND VOLTAGE, AC 100V FOR 1 MINUTE.
 - 4-4. LOW CONTACT RESISTANCE: INITIAL 40MΩ
AFTER 50MΩ
5. ENVIRONMENTAL PERFORMANCE:
 - OPERATING TEMPERATURE: -30°C~+80°C.
6. IR REFLOW:
 - THE PEAK TEMPERATURE ON THE BOARD SHALL BE MAINTAINED FOR 10 SECONDS AT 260°C.



| 4 | SHELL | SUS304 T=0.30MM | NI 30u"MIN | 1PCS |
|-----|-----------------|-----------------|--|------|
| 3 | SHIELDING PLATE | SUS301 T=0.15MM | N/A | 1PCS |
| 2 | CONTACT | C2680 T=0.15MM | Mating area 3u"Au Solder Tails: G/F Underplate: 50u"Min Ni overall | 2SET |
| 1 | INSERT MOLDING | LCP UL94V-0 | Blue | 1PCS |
| NO. | DESCRIPTION | MATERIAL | REMARKS | |

THIS DOCUMENT IS THE SOLE PROPERTY OF BBJconn Technology Co., Ltd. Corporation AND SHOULD NOT BE USED IN WHOLE OR IN PART WITHOUT PRIOR WRITTEN PERMISSION.

PDWG,NO: 0100-2

深圳市步步精科技有限公司

NAME: TYPE-C 16P 母座 板上四脚插 L=8.0 CH=3.18 垫高1.60 带柱 端子SMT LCP蓝胶 镀金3U 带帘

| | | |
|-------|----------|--|
| APPD. | JM_Zheng | PJ. NO.: 126-221-160007-V2G |
| CHKD. | LYX | |
| DR. | TSP | FINISH: SEE NOTES MAT'L.: SEE NOTES |
| | | SCALE: N/A REV.: A0 UNIT: mm PAGE: 1/3 |

| REV. | ECN NO | CONTENT | DATE | ENGINEER |
|------|--------|-----------------|------|----------|
| A0 | | Initial release | / | TSP |

USB TYPE-C PIN ASSIGNMENTS

| PIN NUMBER | SIGNAL NAME | PIN NUMBER | SIGNAL NAME |
|------------|-------------|------------|-------------|
| A1 | GND | B12 | GND |
| A4 | VBUS | B9 | VBUS |
| A5 | CC1 | B8 | SBU2 |
| A6 | Dp1 | B7 | Dn2 |
| A7 | Dn1 | B6 | Dp2 |
| A8 | SBU1 | B5 | CC2 |
| A9 | VBUS | B4 | VBUS |
| A12 | GND | B1 | GND |

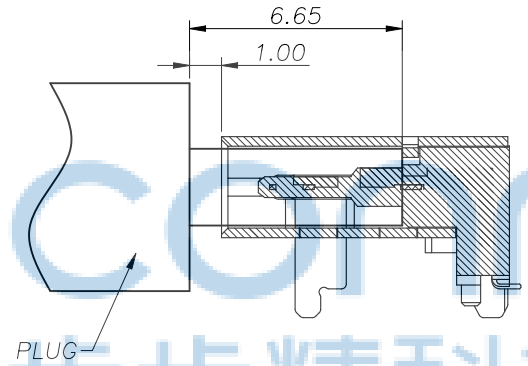
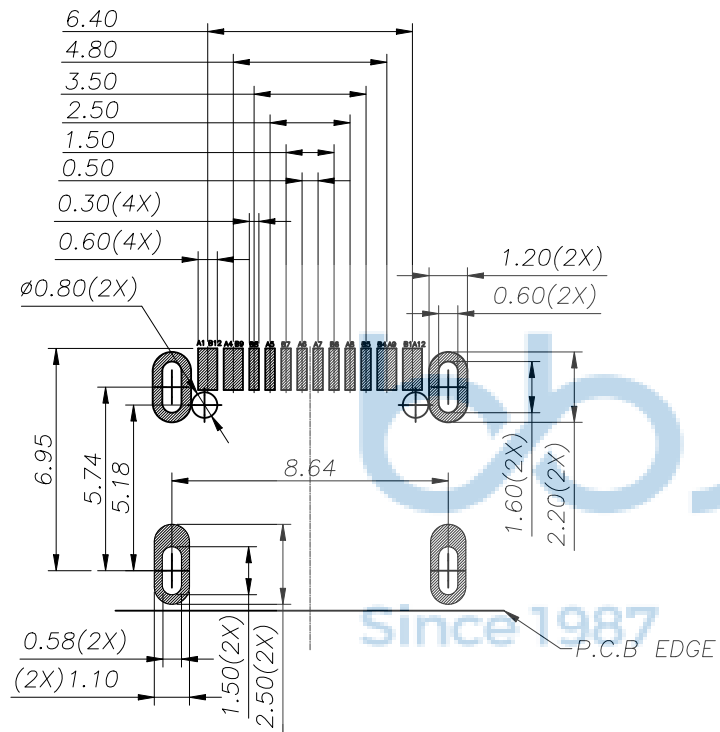

AFTER MATING
SCALE 1:1



RECOMMEND P.C.B LAYOUT(COMPONENT SIDE)
TOLERANCE FOR PCB LAYOUT IS ± 0.05



| | | | |
|--|-----------------|---|-----------------------------|
| THIS DOCUMENT IS THE SOLE PROPERTY OF BBJconn Technology Co.,Ltd. Corporation AND SHOULD NOT BE USED IN WHOLE OR IN PART WITHOUT PRIOR WRITTEN PERMISSION. | | 深圳市步步精科技有限公司 | |
| .X: ±0.38 .XX: ±0.25 .XXX: ±0.13 | | NAME: TYPE-C 16P 母座 板上四脚插 L=8.0 CH=3.18 垫高1.60 带柱 端子SMT LCP蓝胶 镀金3U 编带 | |
| X*: ±3" .X*: ±2" .XX*: ±1" | | PJ. NO.: 126-221-160007-V2G | |
| APPD. JM_Zheng | CHKD. LYX | SIZE: A4 DRW NO.: | |
| DR. TSP | PDWG.NO: 0100-2 | FINISH: SEE NOTES MAT'L.: SEE NOTES | |
| | | SCALE: N/A | REV.: A0 UNIT: mm PAGE: 2/3 |

出料方向
PULL OUT DIRECTEON

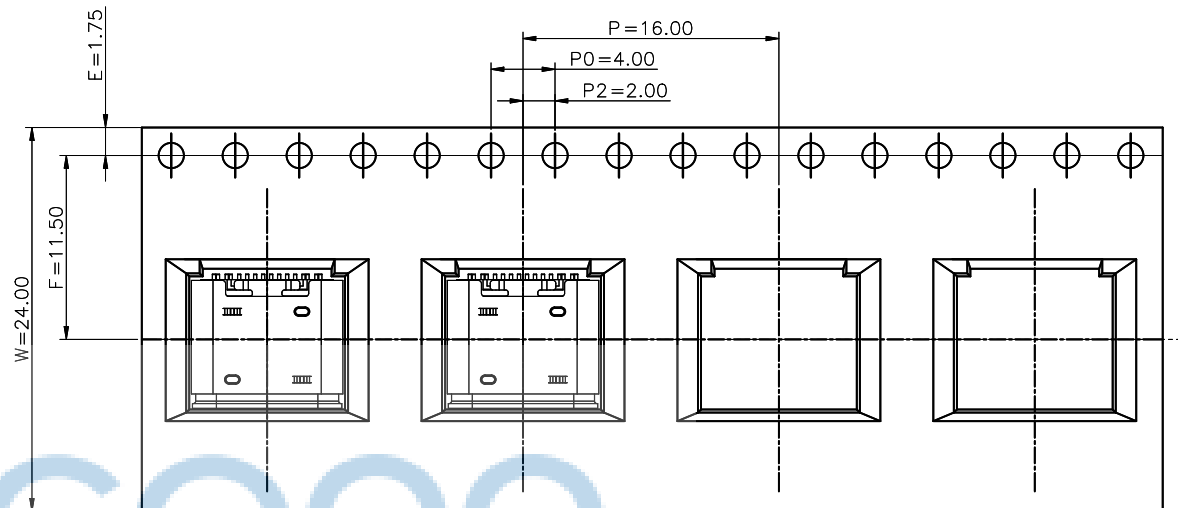
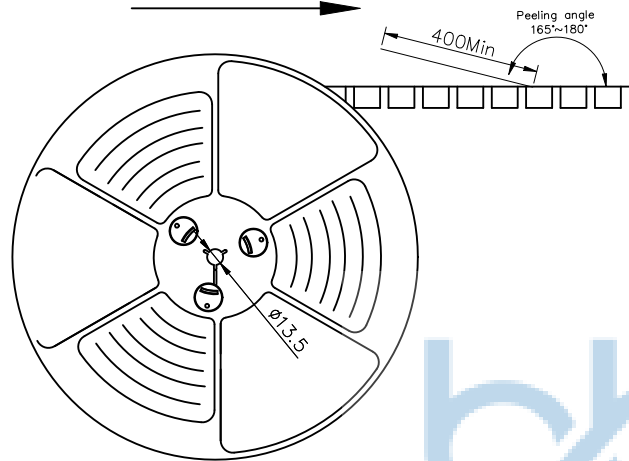

NOTES

1. 帶子引導長度
LEAD TAPE LENGTH
出料方向
PULL OUT DIRECTEON

出料方向
PULL OUT DIRECTEON

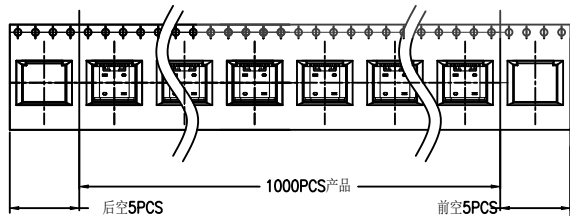

2. 上帶 剝離力為 : 0.1~1.3N(10.2gf~130gf)
PEELING OFF FORCE OF TOP TAPE: 0.1~1.3N(10.2gf~130gf)
出貨運輸過程中一定注意:
THIS REQUIREMENT SHOULD BE APPLIED AT SHIPMENT:
卷帶在運輸過程中不能散開
PEELING OFF SHOULD NOT BE ALLOWED DURING TRANSPORTATION

TAPE & REEL 6 PCS

1 REEL
= 1000 PCS

BOX

DIMENSIONS:
39.5X39.5X20

1 CARTON
=6REELS
=6000 PCS



THIS DOCUMENT IS THE SOLE PROPERTY OF BBJconn Technology Co., Ltd. Corporation AND SHOULD NOT BE USED IN WHOLE OR IN PART WITHOUT PRIOR WRITTEN PERMISSION.
PDWG.NO: 0100-2

深圳市步步精科技有限公司

.X: ±0.38 .X': ±3'
.XX: ±0.25 .X'': ±2'
.XXX: ±0.13 .X''': ±1'

NAME: TYPE-C 16P 母座 板上四脚插 L=8.0 CH=3.18 垫高1.60 带柱 端子SMT LCP蓝胶 镀金3U 编带

APPD. JM_Zheng

PJ. NO.: 126-221-160007-V2G

CHKD. LYX

SIZE: A4 DRW NO.:

DR. TSP

FINISH: SEE NOTES MAT'L.: SEE NOTES

SCALE: N/A REV.: A0 UNIT: mm PAGE: 3/3

| 包裝明細表 (The detail of the packing) Carton | | | | | | |
|--|-------------------------|--------------|---------|----------------|------------|------------|
| 產品料號 (Product No.) | 包裝容量 (Packing Capacity) | | | 重量 Weight (Kg) | | |
| | pcs/box | boxes/Carton | Pcs/Box | N. W. /Pcs | N. W. /Box | G. W. /Box |
| | 1000 | 6 | 6000 | ---- | ---- | ---- |