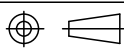

REV.	DESCRIPTION	NAME	DATE
A	NEWS ISSUE		

NOTE:

- MATERIAL SPECIFICATION:
 - HOUSING: HIGH TEMPERATURE RESISTANT PLASTIC, UL94 V-0.
 - CONTACTS: COPPER ALLOY
 - MID PLATE: STAINLESS STEEL
 - INSIDE SHELL: STAINLESS STEEL
 - OUTSIDE SHELL: STAINLESS STEEL
- PLATING SPECIFICATION:
 - CONTACTS:
 - Ni 50u" MIN. UNDER PLATED OVER ALL.
 - Au PLATED ON THE FUNCTIONAL AREA OF CONTACT.
 - INSIDE SHELL OR OUTSIDE SHELL:
 - GOLD FLASH PLATING ON SOLDER AREA
 - Ni 30u" MIN. UNDER PLATED OVER ALL.
- MECHANICAL PERFORMANCE,
 - INSERTION FORCE: 0.5~2.0kgf.
 - REMOVAL FORCE: 0.8kgf~2.0kgf.
 - DURABILITY: 10000 CYCLES.
- ELECTRICAL PERFORMANCE,
 - CURRENT RATING: 5A
VOLTAGE RATING: 20V
 - INSULATION RESISTANCE: 100MΩ MIN
 - DIELECTRIC WITHSTAND VOLTAGE, AC 100V FOR 1 MINUTE.
 - LOW CONTACT RESISTANCE: INITIAL 40MΩ
AFTER 50MΩ
- ENVIRONMENTAL PERFORMANCE:
 - OPERATING TEMPERATURE: -30°C~+80°C.
- IR REFLOW:
 - THE PEAK TEMPERATURE ON THE BOARD SHALL BE MAINTAINED FOR 10 SECONDS AT 260°C.

NO.	DESCRIPTION	MATERIAL	REMARKS	
5	OUTER SHELL	SUS304 T=0.25MM	NI 40u"MIN	1PCS
4	INNER SHELL	SUS304 T=0.30MM	NI 40u"MIN	1PCS
3	SHIELDING PLATE	SUS301 T=0.15MM	N/A	1PCS
2	CONTACT	C2680 T=0.15MM	Mating area 1u"Au Solder Tails: G/F Underplate: 80u"Min Ni overall	2SET
1	INSERT MOLDING	LCP UL94V-0	BLACK	1PCS

TOLERANCE UNSPECIFIED .0 ±0.35 .00 ±0.25 .000 ±0.15 X.° ±2.00° CUSTOMER DRAWING		 深圳市步步精科技有限公司	
TITLE: TYPE-C 16P 母座 90度 板上垫高3.0 四脚插 带柱 L=8.0 CH=4.58 脚长1.0 (改模)			
DRAWN/ DATE 设计 LHC	SIZE: A4 UNIT: MM.	PART. NO: UC.01.11-11-0001	
CHECKED/ DATE 审核 LYX	SCALE: 1:1	PROJECTION 	REV.: 版本
APPROVED/ DATE 核准 LJP	DWG. PATH	0100-2	SHEET: 页码

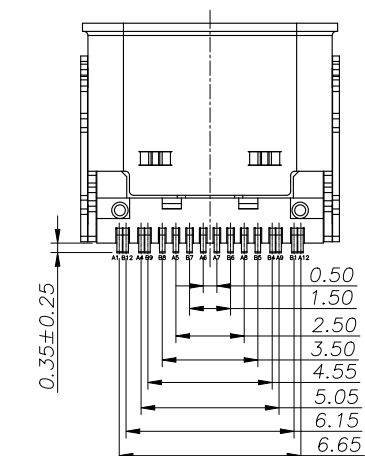
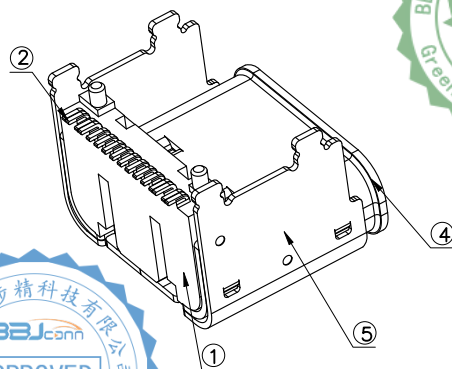
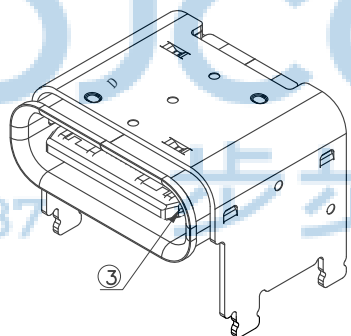
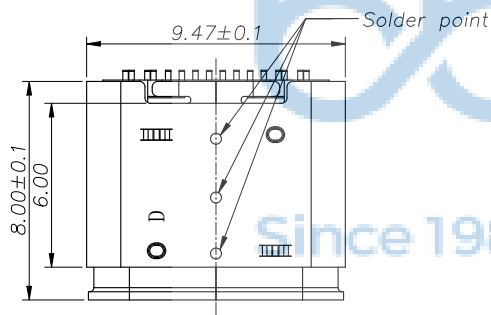
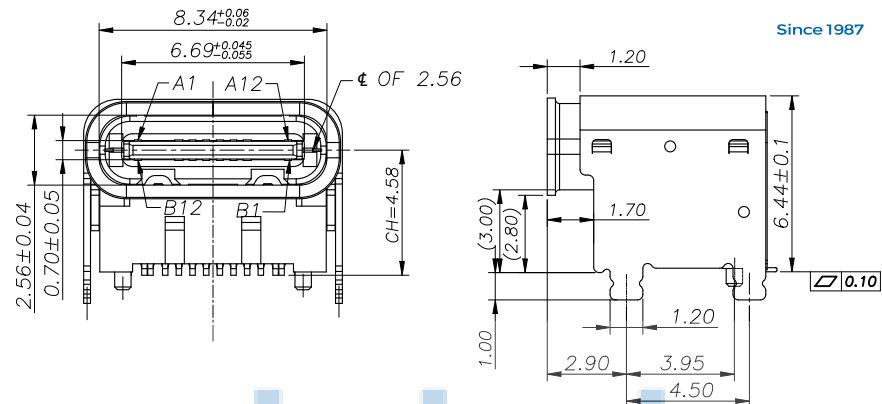

REV.	DESCRIPTION	NAME	DATE
A	NEWS ISSUE		

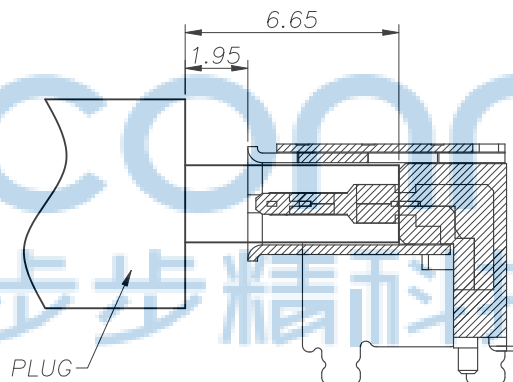
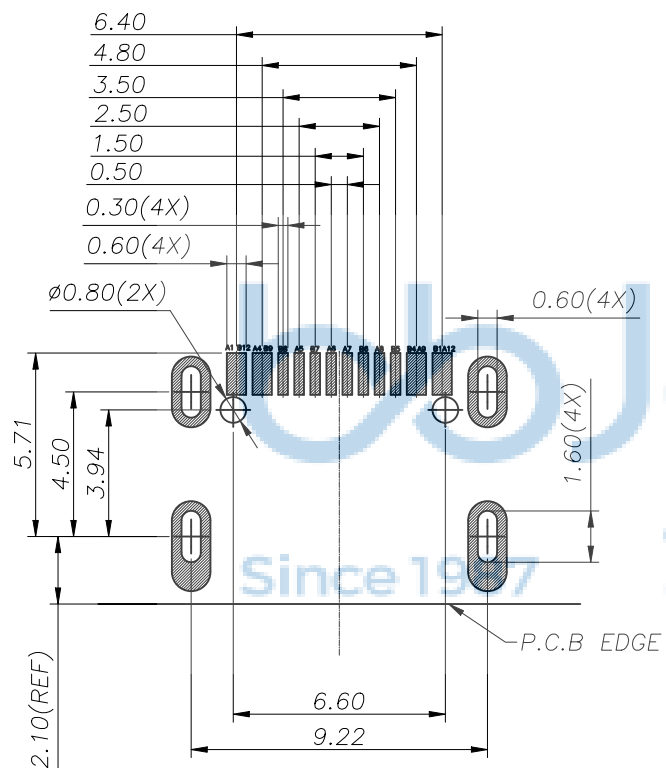

USB TYPE-C PIN ASSIGNMENTS

PIN NUMBER	SIGNAL NAME	PIN NUMBER	SIGNAL NAME
A1	GND	B12	GND
A4	VBUS	B9	VBUS
A5	CC1	B8	SBU2
A6	Dp1	B7	Dn2
A7	Dn1	B6	Dp2
A8	SBU1	B5	CC2
A9	VBUS	B4	VBUS
A12	GND	B1	GND

RECOMMEND P.C.B LAYOUT(COMPONENT SIDE)
TOLERANCE FOR PCB LAYOUT IS ± 0.05



TOLERANCE UNSPECIFIED		深圳市步步精科技有限公司 TITLE: TYPE-C 16P 母座 90度 板上垫高3.0 四脚插 带柱 L=8.0 CH=4.58 脚长1.0 (改模)	
.0	± 0.35		
.00	± 0.25		
.000	± 0.15		
X.°	$\pm 2.00^\circ$		
CUSTOMER DRAWING			
DRAWN/ DATE	设计 LHC	SIZE: A4	UNIT: MM. PART. NO: UC.01.11-11-0001
CHECKED/ DATE	审核 LYX	SCALE: 1:1	PROJECTION
APPROVED/ DATE	核准 LJP	DWG. PATH	REV.: 版本 SHEET: 页码
			0100-2

REV.	DESCRIPTION	NAME	DATE
A	NEWS ISSUE		

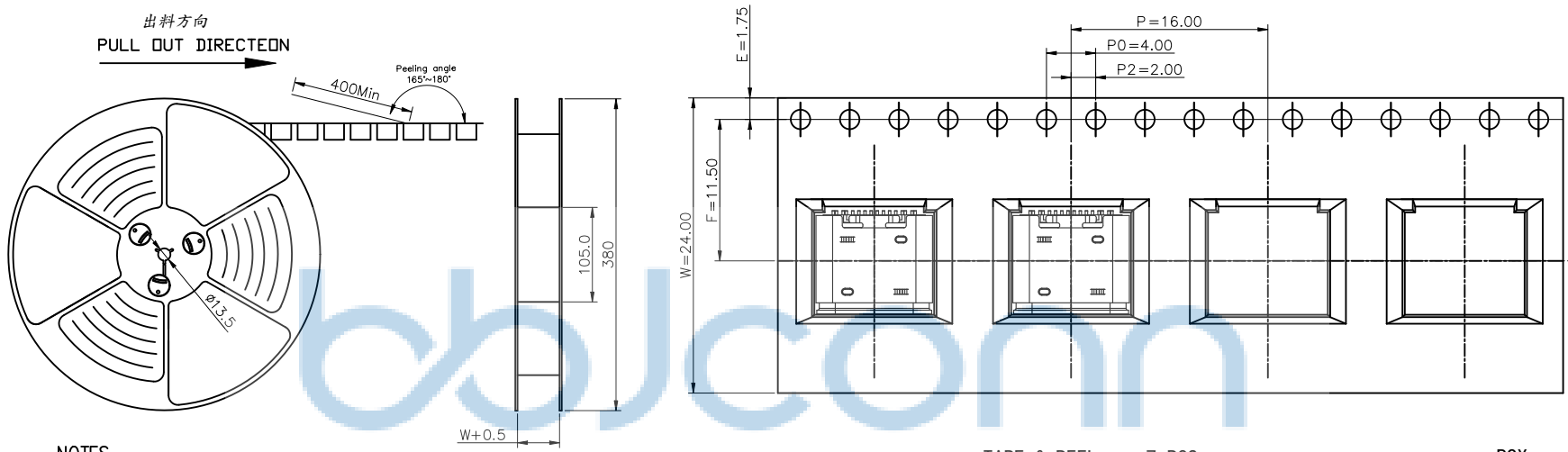

NOTES

- 帶子引導長度
LEAD TAPE LENGTH
出料方向
PULL OUT DIRECTEON
- 上帶 剝離力為：0.1~1.3N(10.2gf~130gf)
PEELING OFF FORCE OF TOP TAPE: 0.1~1.3N(10.2gf~130gf)
出貨運輸過程中一定注意：
THIS REQUIREMENT SHOULD BE APPLIED AT SHIPMENT：
卷帶在運輸過程中不能散開
PEELING OFF SHOULD NOT BE ALLOWED DURING TRANSPORTATION

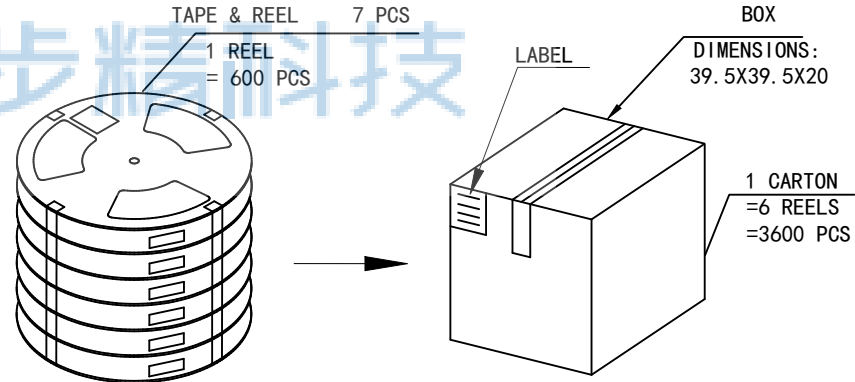
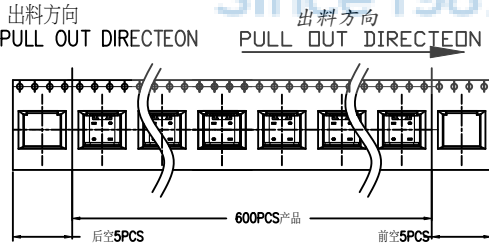

TOLERANCE UNSPECIFIED		深圳市步步精科技有限公司 TITLE: TYPE-C 16P 母座 90度 板上垫高3.0 四脚插 带柱 L=8.0 CH=4.58 脚长1.0 (改模)	
.0	±0.35	SIZE: A4	UNIT: MM.
.00	±0.25	PART. NO: UC.01.11-11-0001	
.000	±0.15	SCALE: 1:1	PROJECTION
X. °	±2.00°	REV.: 版本	
CUSTOMER DRAWING		DWG. PATH	0100-2
DRAWN/ DATE	设计 LHC	SHEET: 页码	
CHECKED/ DATE	审核 LYX		
APPROVED/ DATE	核准 LJP		

包裝明細表 (The detail of the packing) Carton					
包裝容量 (Packing Capacity)			重量 Weight (Kg)		
pcs/box	boxs/Carton	Pcs/Box	N. W. /Pcs	N. W. /Box	G. W. /Box
600	6	3600	----	----	----