

REV.	ECN NO.	CONTENT	DATE	ENGINEER
AO			2023 20/04	

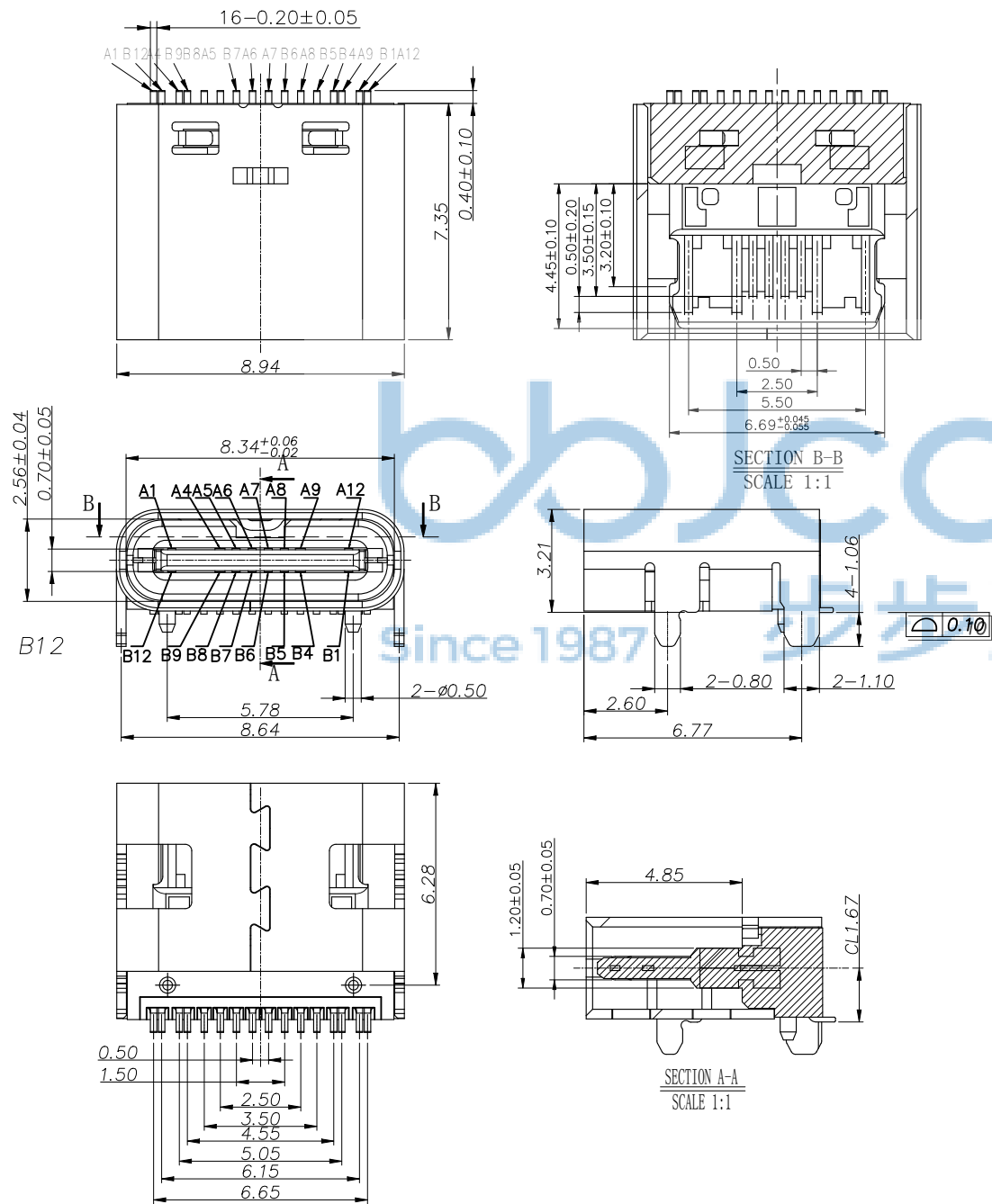

- NOTE:
- MATERIAL SPECIFICATION:
    - HOUSING: HIGH TEMPERATURE RESISTANT PLASTIC, UL94 V-0.
    - CONTACTS: COPPER ALLOY
    - MID PLATE: STAINLESS STEEL
  - PLATING SPECIFICATION:
    - CONTACTS:
      - Ni 50u" MIN. UNDER PLATED OVER ALL.
      - Au PLATED ON THE FUNCTIONAL AREA OF CONTACT.
      - GOLD FLASH PLATING ON SOLDER AREA
    - FRONT SHELL:
      - Ni 30u" MIN. UNDER PLATED OVER ALL.
  - MECHANICAL PERFORMANCE,
    - INSERTION FORCE: 0.5~2.0kgf.
    - REMOVAL FORCE: 0.8kgf~2.0kgf.
    - DURABILITY: 10000 CYCLES.
  - ELECTRICAL PERFORMANCE,
    - CURRENT RATING: 5A  
VOLTAGE RATING: 20V
    - INSULATION RESISTANCE: 100MΩ MIN
    - DIELECTRIC WITHSTAND VOLTAGE, AC 100V FOR 1 MINUTE.
  - ENVIRONMENTAL PERFORMANCE:
    - OPERATING TEMPERATURE: -30°C~+80°C.
  - IR REFLOW:
    - THE PEAK TEMPERATURE ON THE BOARD SHALL BE MAINTAINED FOR 10 SECONDS AT 260°C.



THIS DOCUMENT IS THE SOLE PROPERTY OF BBJconn Technology Co., Ltd. Corporation AND SHOULD NOT BE USED IN WHOLE OR IN PART WITHOUT PRIOR WRITTEN PERMISSION.		<b>深圳市步步精科技有限公司</b> 工程部	
PDWG. NO: 0100-2	DR. LYX	NAME: TYPE-C 16PIN 母座 L=7.35 CH=1.67 板上 一体式 铜合金端子SMT (5A) PA10T红胶	P.J. NO.: UC.01.51-11-0051 SIZE: A4 DRW NO.:
APPD. JM_Zheng	CHKD. TSP	FINISH: SEE NOTES	MAT'L.: SEE NOTES
		SCALE: N/A	REV.: AO UNIT: mm PAGE: 1/1

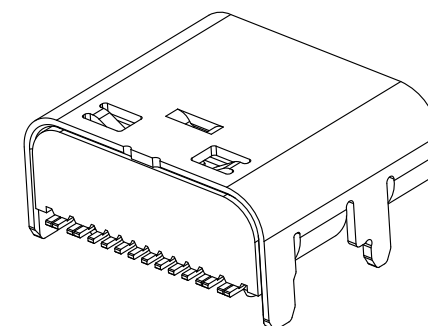
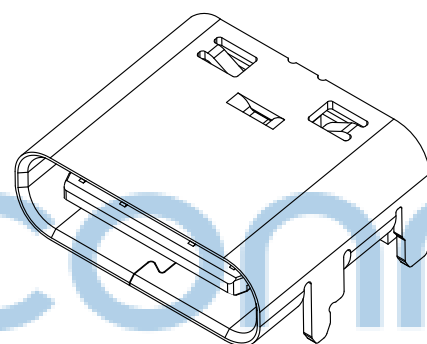
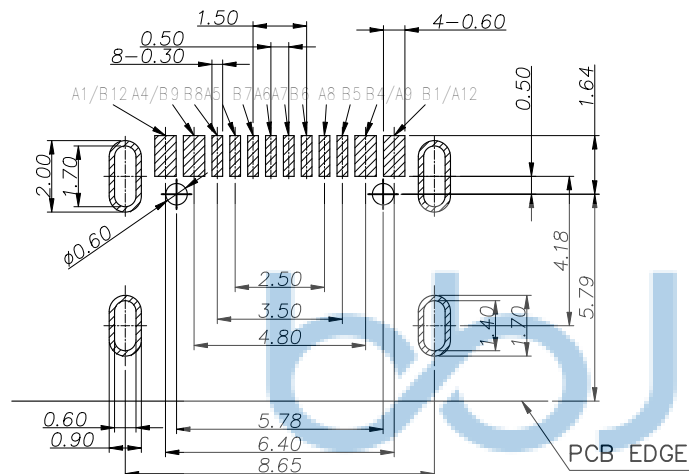

RECOMMEND P.C.B LAYOUT (COMPONENT SIDE)  
TOLERANCE FOR PCB LAYOUT IS  $\pm 0.05$

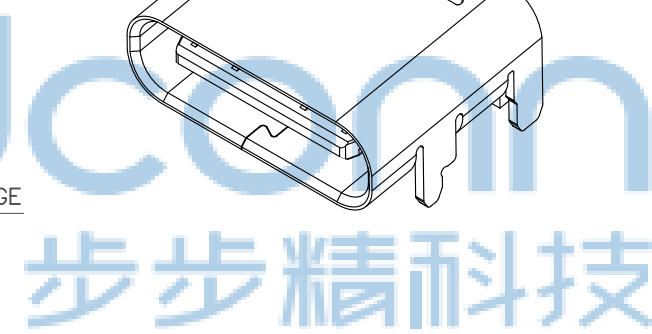

USB TYPE-C PIN ASSIGNMENTS

PIN NUMBER	SIGNAL NAME	PIN NUMBER	SIGNAL NAME
A1	GND	B12	GND
A4	VBUS	B9	VBUS
A5	CC1	B8	SBU2
A6	Dp1	B7	Dn2
A7	Dn1	B6	Dp2
A8	SBU1	B5	CC2
A9	VBUS	B4	VBUS
A12	GND	B1	GND



THIS DOCUMENT IS THE SOLE PROPERTY OF BBJconn Technology Co., Ltd. Corporation AND SHOULD NOT BE USED IN WHOLE OR IN PART WITHOUT PRIOR WRITTEN PERMISSION.		深圳市步步精科技有限公司 .X: $\pm 0.38$ X: $\pm 3^*$ .XX: $\pm 0.25$ .X: $\pm 2^*$ .XXX: $\pm 0.13$ .XX: $\pm 1^*$		NAME: TYPE-C 16PIN 母座 L=7.35 CH=1.67 板上 一体式 铜合金端子SMT (5A) PA10T红胶	
APPD.	JM_Zheng	PJ. NO.: UC.01.51-11-0051 SIZE: A4 DRW NO.:		FINISH: SEE NOTES MAT'L.: SEE NOTES	
CHKD.	TSP	SCALE: N/A		REV.: A0	UNIT: mm
PDWG. NO:	0100-2	DR.	LYX	PAGE: 1/1	

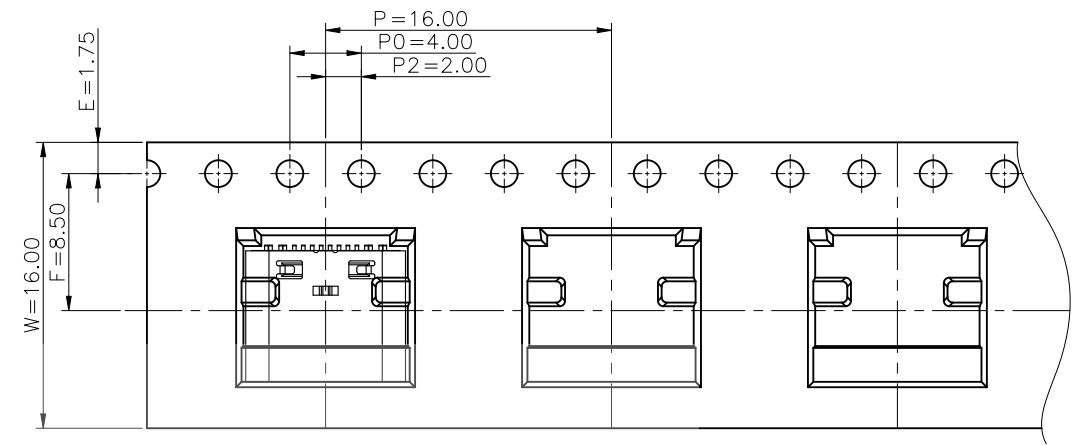
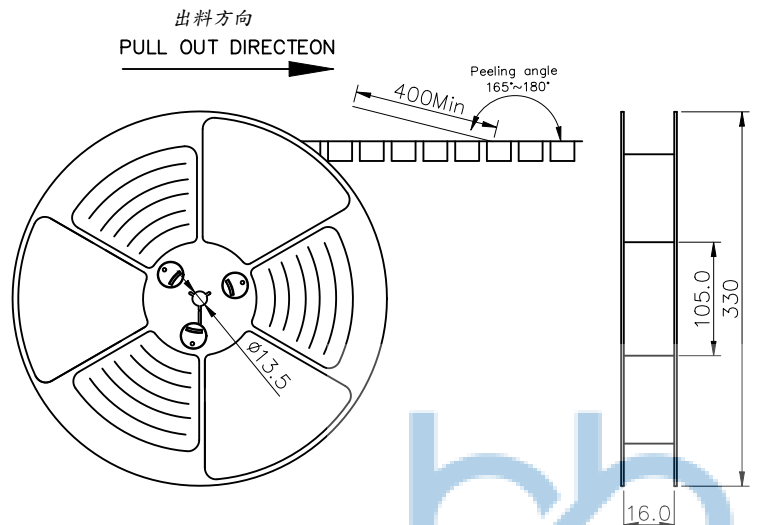

NOTES

1. 帶子引導長度  
LEAD TAPE LENGTH  
出料方向  
PULL OUT DIRECTEON

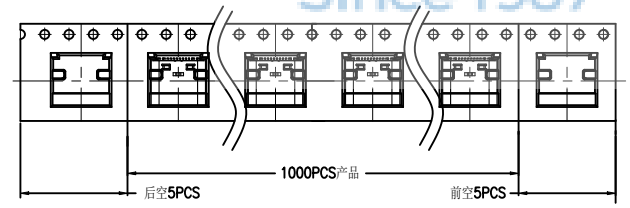

2. 上帶剝力力為: 0.1~1.3N(10.2gf~130gf)  
PEELING OFF FORCE OF TOP TAPE: 0.1~1.3N(10.2gf~130gf)  
出貨運輸過程中一定注意:  
THIS REQUIREMENT SHOULD BE APPLIED AT SHIPMENT:  
卷帶在運輸過程中不能散開  
PEELING OFF SHOULD NOT BE ALLOWED DURING TRANSPORTATION

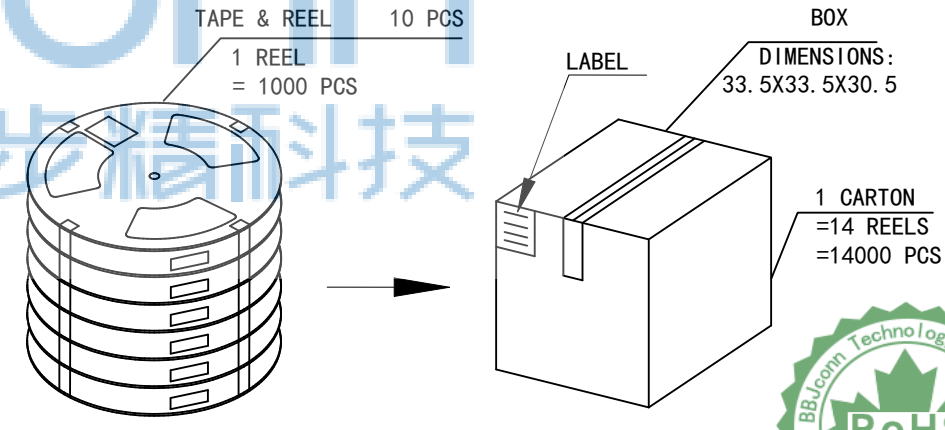

包裝明細表 (The detail of the packing) Carton					
包裝容量 (Packing Capacity)			重量 Weight (Kg)		
pcs/box	boxes/Carton	Pcs/Box	N. W. /Pcs	N. W. /Box	G. W. /Box
1000	14	14000	---	---	---

THIS DOCUMENT IS THE SOLE PROPERTY OF BBJconn Technology Co., Ltd. Corporation AND SHOULD NOT BE USED IN WHOLE OR IN PART WITHOUT PRIOR WRITTEN PERMISSION.		深圳市步步精科技有限公司 .X: ±0.38 X: ±3* .XX: ±0.25 .X: ±2* .XXX: ±0.13 .XX: ±1*		NAME: TYPE-C 16PIN 母座 L=7.35 CH=1.67 板上 一体式 铜合金端子SMT (5A) PA10T红胶	
APPD.	JM_Zheng	P.J. NO.: UC.01.51-11-0051		SIZE: A4 DRW NO.:	
CHKD.	TSP	FINISH: SEE NOTES		MAT'L.: SEE NOTES	
PDWG.NO:	0100-2	DR.	LYX	SCALE: N/A	REV.: AO UNIT: mm PAGE: 1/1