



REV.	DESCRIPTION	NAME	DATE
A	NEWS ISSUE		

NOTE:

1.MATERIAL SPECIFICATION:

- 1.HOUSING:HIGH TEMPERATURE RESISTANT PLASTIC,UL94 V-0(LCP), GREEN(802C)
- 2.CONTACTS: COPPER ALLOY(C2680)
- 3.MID-PLATED: STANLESS STEEL(SUS301)

2.PLATING SPECIFICATION:

2-1.CONTACTS:

- Ni 50u" MIN. UNDER PLATED OVER ALL.
- Au PLATED ON THE FUNCTIONAL AREA OF CONTACT.
- GOLD FLASH PLATING ON SOLDER AREA

2-2.FRONT SHELL:

3.MECHANICAL PERFORMANCE,

- 3-1.INSERTION FORCE: 0.5~2.0kgf.
- 3-2.REMOVAL FORCE: 0.8kgf~2.0kgf.
- 3-3.DURABILITY: 10000 CYCLES.

4.ELECTRICAL PERFORMANCE,

- 4-1. CURRENT RATING: 5.0A
- VOLTAGE RATING: 20V
- 4-2.INSULATION RESISTANCE: 100MΩ MIN MINUTE.
- 4-3.DIELECTRIC WITHSTAND VOLTAGE,AC 100V FOR 1

5. ENVIRONMENTAL PERFORMANCE:

- OPERATING TEMPERATURE: -30°C~+80°C.

6.IR REFLOW:

- THE PEAK TEMPERATURE ON THE BOARD SHALL BE MAINTAINED FOR 10 SECONDS AT 260°C.

USB TYPE-C PIN ASSIGNMENTS

PIN NUMBER	SIGNAL NAME
A5	CC1
A9	VBUS
A12	GND
B12	GND
B9	VBUS
B5	CC2

Code	DIM L	DIM A
0	6.80	4.90
1	6.50	4.60

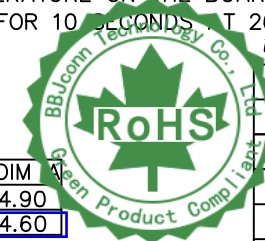

深圳市步步精科技有限公司

TITLE:

YPE-C 6P 母座板上四脚插L=6.8 CH1.63 带中夹片 绿胶 SMT

TOLERANCE UNSPECIFIED	
.0	±0.35
.00	±0.25
.000	±0.15
X. °	±2.00°
CUSTOMER DRAWING	

DRAWN/ DATE	设计 LYX	SIZE:A4	UNIT:MM.	PART. NO:	UC.01.53-11-0015
CHECKED/ DATE	审核 HMY	SCALE: 1:1	PROJECTION	REV.:	版本
APPROVED/ DATE	核准 LJP	DWG. PATH	0100-2	SHEET:	页码

RECOMMEND P.C.B LAYOUT(COMPONENT SIDE)

TOLERANCE FOR PCB LAYOUT IS ± 0.05

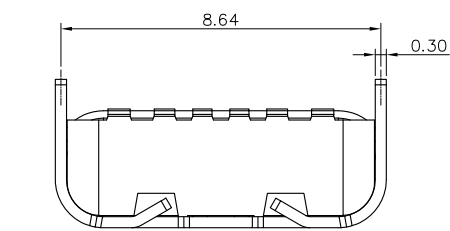
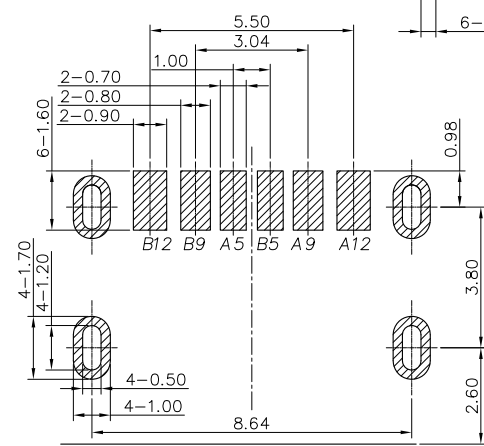
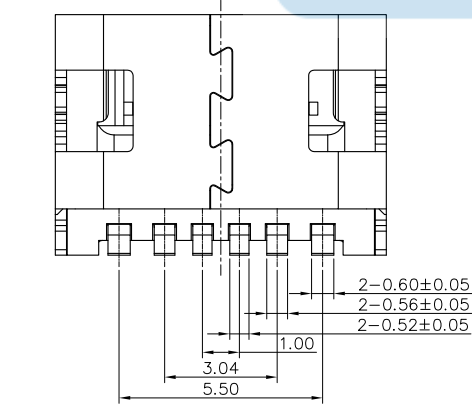
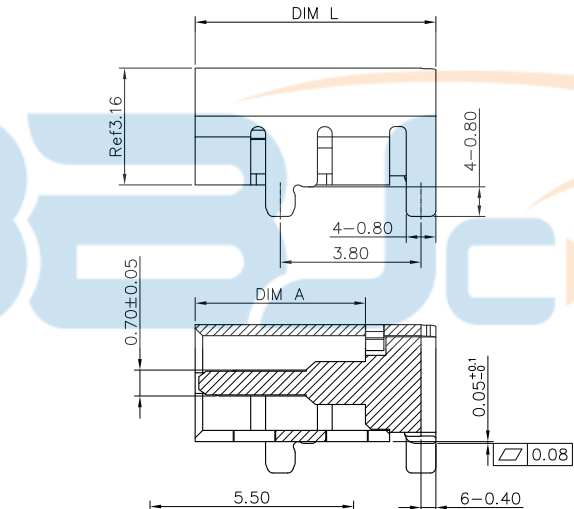
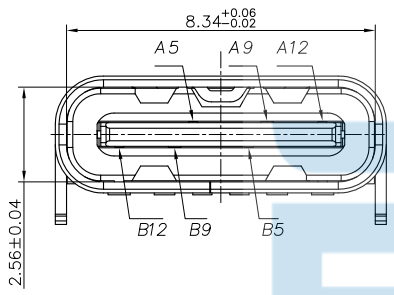
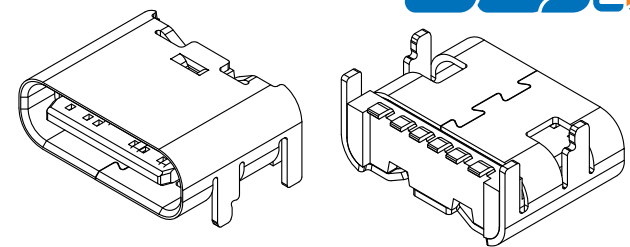
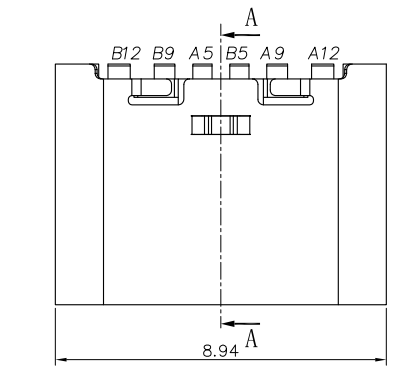



REV.	DESCRIPTION	NAME	DATE
A	NEWS ISSUE		

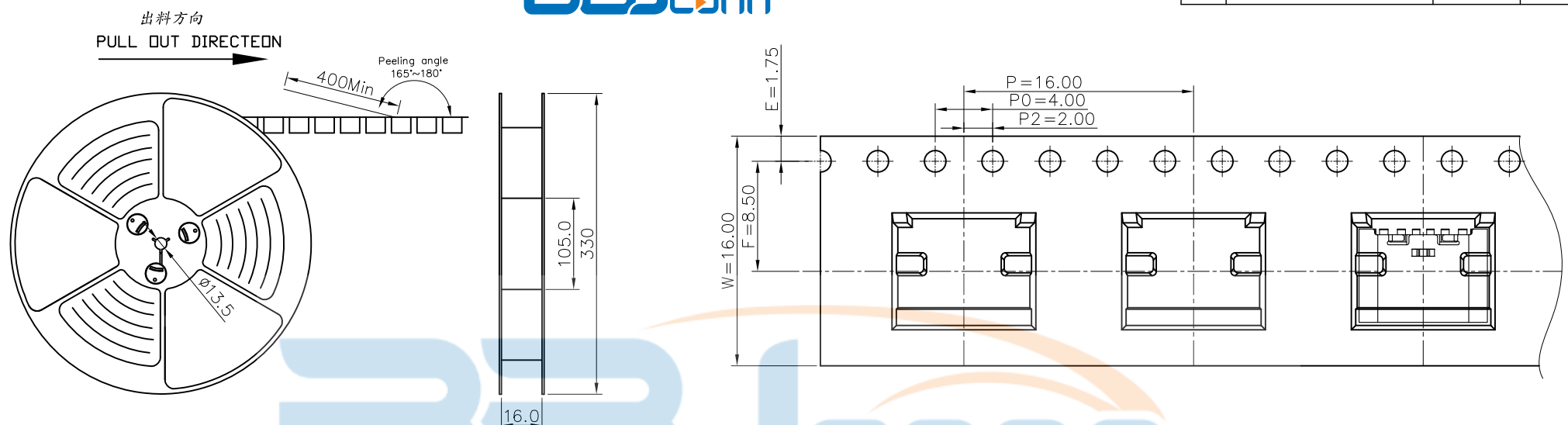

NOTES

1. 帶子引導長度
LEAD TAPE LENGTH
 出料方向
PULL OUT DIRECTEON

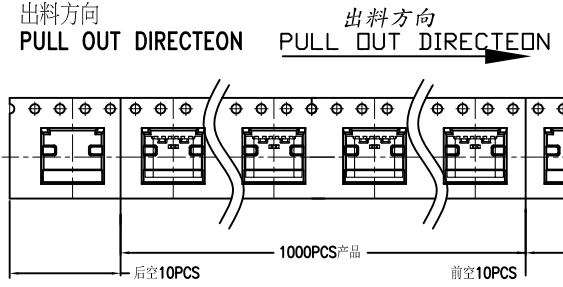

2. 上帶 剝力力為 : 0.1~1.3N(10.2gf~130gf)
PEELING OFF FORCE OF TOP TAPE:0.1~1.3N(10.2gf~130gf)
 出貨運輸過程中一定注意 :
THIS REQUIREMENT SHOULD BE APPLIED AT SHIPMENT :
 卷帶在運輸過程中不能散開
PEELING OFF SHOULD NOT BE ALLOWED DURING TRANSPORTATION

TAPE & REEL 14 PCS
 1 REEL = 1000 PCS

BOX
 DIMENSIONS:
 33.5X33.5X30.5

1 CARTON
 =14 REELS
 =14000 PCS

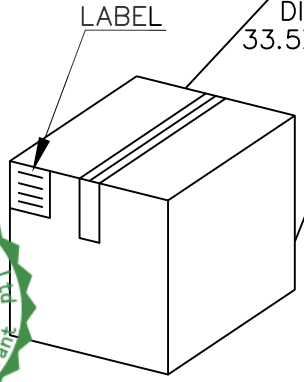
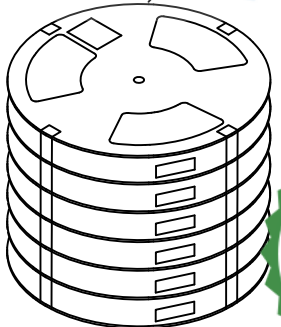

TOLERANCE UNSPECIFIED		.0 ±0.35		深圳市步步精科技有限公司 TITLE: YPE-C 6P 母座板上四脚插L=6.8 CH1.63 带中夹片 绿胶 SMT	
		.00 ±0.25			
		.000 ±0.15			
		X. ° ±2.00°			
CUSTOMER DRAWING					
DRAWN/ DATE	设计 LYX	SIZE:A4	UNIT:MM.	PART. NO:	UC.01.53-11-0015
CHECKED/ DATE	审核 HMY	SCALE: 1:1	PROJECTION	REV.:	版本
APPROVED/ DATE	核准 LJP	DWG. PATH	0100-2	SHEET:	页码

包裝明細表 (The detail of the packing) Carton

產品料號 (Product No.)	包裝容量 (Packing Capacity)			重量 Weight (Kg)		
	pcs/box	boxes/Carton	Pcs/Box	N.W./Pcs	N.W./Box	G.W./Box
	1000	14	14000	----	----	----