

REV.	ECN NO	CONTENT	DATE	ENGINEER
A0		Initial release	/	TSP

NOTE:

- MATERIAL SPECIFICATION:
 - HOUSING: HIGH TEMPERATURE RESISTANT PLASTIC, UL94 V-0.
 - CONTACTS: COPPER ALLOY
 - SHELL: SUS304
- PLATING SPECIFICATION:
 - CONTACTS:
 - Ni 50u" MIN. UNDER PLATED OVER ALL.
 - Au PLATED ON THE FUNCTIONAL AREA OF CONTACT. (GOLD PLATING THICKNESS FOLLOW)
 - 120u" Min Tin PLATING ON SOLDER AREA
 - SHELL:
 - Ni 30u" MIN. UNDER PLATED OVER ALL.
- ELECTRICAL PERFORMANCE,
 - CONTACT RESISTANCE:
 - 40mΩ Max FOR INITIAL. 10mΩ Max CHANGE AFTER TEST.
 - CONTACT CURRENT RATING:
 - CURRENT RATING: 2.0 A
 - VOLTAGE RATING: 5V
 - DIELECTRIC WITHSTAND VOLTAGE, AC 100V FOR 1 MINUTE.
 - INSULATION RESISTANCE: 100MΩ MIN
 - OPERATING TEMPERATURE: -30° C~+80° C.
- MECHANICAL PERFORMANCE,
 - INSERTION FORCE: 0.5~2.0kgf.
 - REMOVAL FORCE: 0.8kgf~2.0kgf.
 - DURABILITY: 1000 CYCLES.
- IR REFLOW:
 - THE PEAK TEMPERATURE ON THE BOARD SHALL BE MAINTAINED FOR 10 SECONDS AT 260° C.
- NEED TO MEET USB 2.0 TYPE-C ASSOCIATION SPECIFICATION.
- PRODUCT COMPLIANT TO ROHS.
- SALT SPRAY REQUIREMENTS:
 - GOLD PLATING AREA AT LEAST 48H.

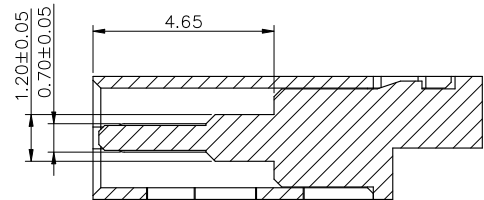
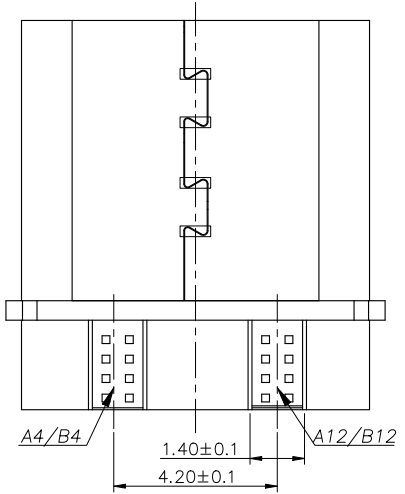
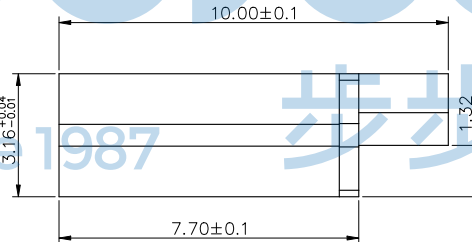
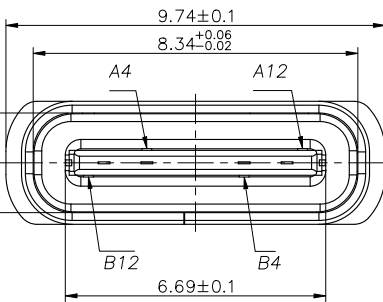
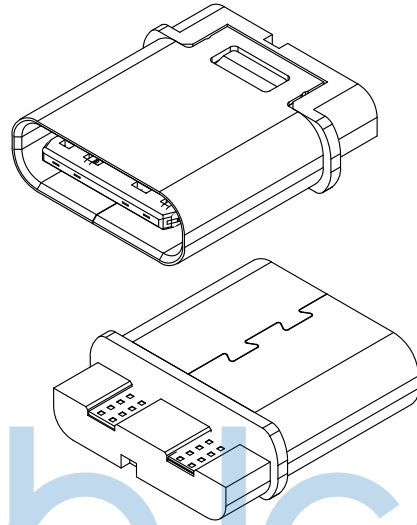
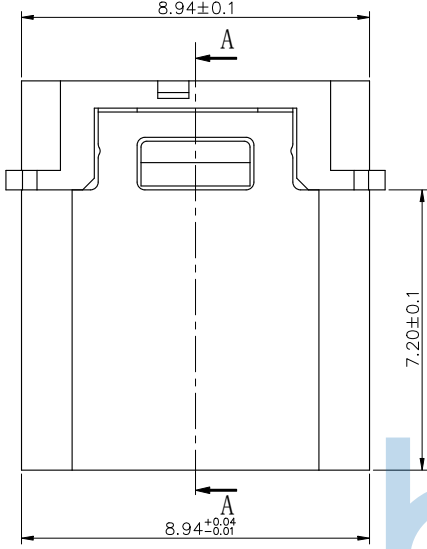

SECTION A-A
SCALE 1:1

USB TYPE-C PIN ASSIGNMENTS

PIN NUMBER	SIGNAL NAME
A4	VBUS
A12	GND
B12	GND
B4	VBUS

THIS DOCUMENT IS THE SOLE PROPERTY OF BBJconn Technology Co., Ltd. Corporation AND SHOULD NOT BE USED IN WHOLE OR IN PART WITHOUT PRIOR WRITTEN PERMISSION.		深圳市步步精科技有限公司 工程管理部	
PDWG.NO: 0100-2	DR. TSP	NAME: TYPE-C 4P 母座 焊线式 充电款 L=10.0	
APPD. JM_Zheng	CHKD. LYX	PJ. NO.: UC.01.87-31-0001	
		SIZE: A4 DRW NO.:	
		FINISH: SEE NOTES	MAT'L.: SEE NOTES
		SCALE: N/A	REV.: A0 UNIT: mm PAGE: 1/2

一.
將成品放入袋子內,如圖所示。
Put the finished product into the bag. Direction refers to below drawing.

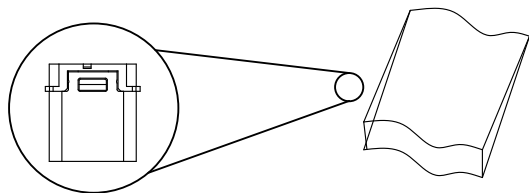

VIEW-1

- 二.
- 一只紙箱可放置之PE 袋見下表。
1) A carton can be placed in PE bags see the table below
 - 每1個紙箱用的包裝數量詳見下表。
2) The Q'ty of products per carton please see next tabel.

每袋5K pcs
一箱四袋

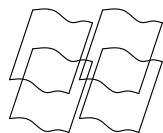

PE 袋

VIEW-2

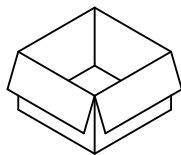

Cushion

? 箱

- 三.
- 將標籤貼於紙箱側麥上方。
Stick the needful label On the up-right corner of the side of carton.

Location of Sticking lable

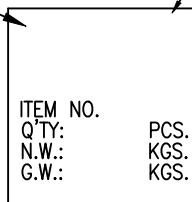

Location of Sticking lable



VIEW-3

備 註 (REMARK)

- 若未裝滿之零數箱, 必須以緩衝材塞滿。
The unfilling-carton must be filled with assuagement.
- 裝滿成品后之外箱, 最大堆積箱數: 5箱
About the box fully filled with products, the MAX accumulating quantity of boxes is 5.
- 如須貼Bar-code, 請依Bar-code作業辦法執行
If barcode lable is required, do it according to the related barcode lable operation standards.



包裝明細表 (The detail of the packing)						
產品料號 (Product No.)	包裝容量 (Packing Capacity)			重量 Weight (Kg)		
	pcs/bag	bogs/Carton	Pcs/Box	N. W. /Pcs	N. W. /Box	G. W. /Box
UC. 01. 87-31-0001	5000	4	20000			

THIS DOCUMENT IS THE SOLE PROPERTY OF BBJconn Technology Co.,Ltd. Corporation AND SHOULD NOT BE USED IN WHOLE OR IN PART WITHOUT PRIOR WRITTEN PERMISSION.		深圳市步步精科技有限公司 .X: ±0.38 .X': ±3" .XX: ±0.25 .X'': ±2" .XXX: ±0.13 .XX': ±1"		NAME: TYPE-C 4P 母座 焊线式 充电款 L=10.0	
APPD.	JM_Zheng	PJ. NO.: UC.01.87-31-0001		SIZE: A4 DRW NO.:	
CHKD.	LYX	FINISH: SEE NOTES		MAT'L.: SEE NOTES	
PDWG.NO:	0100-2	DR.	TSP	SCALE: N/A	REV.: AO UNIT: mm PAGE: 2/2