

NOTE:

- 1.MATERIAL SPECIFICATION:
  - 1.HOUSING:HIGH TEMPERATURE RESISTANT PLASTIC,UL94 V-0.
  - 2.CONTACTS:COPPER ALLOY
  - 3.MID PLATE: STAINLESS STEEL
- 2.PLATING SPECIFICATION:
  - 2-1.CONTACTS:
    - Ni 50u" MIN. UNDER PLATED OVER ALL.
    - Au PLATED ON THE FUNCTIONAL AREA OF CONTACT.
    - (GOLD PLATING THICKNESS FOLLOW THE P/N)
    - GOLD FLASH PLATING ON SOLDER AREA
  - 2-2.FRONT SHELL:
    - Ni 30u" MIN. UNDER PLATED OVER ALL.
- 3.MECHANICAL PERFORMANCE,
  - 3-1.INSERTION FORCE: 0.5~2.0kgf.
  - 3-2.REMOVAL FORCE: 0.8kgf~2.0kgf.
  - 3-3.DURABILITY: 10000 CYCLES.
- 4.ELECTRICAL PERFORMANCE,
  - 4-1. CURRENT RATING: 5A
  - VOLTAGE RATING: 20V
  - 4-2.INSULATION RESISTANCE: 100MΩ MIN
  - 4-3.DIELECTRIC WITHSTAND VOLTAGE,AC 100V FOR 1 MINUTE.
  - 4-4.LOW CONTACT RESISTANCE: INITIAL 40MΩ
  - AFTER 50MΩ
5. ENVIRONMENTAL PERFORMANCE:
  - OPERATING TEMPERATURE: -30°C~+80°C.
- 6.IR REFLOW:
  - THE PEAK TEMPERATURE ON THE BOARD SHALL BE MAINTAINED FOR 10 SECONDS AT 260°C.



TOLERANCE UNSPECIFIED		深圳市步步精科技有限公司 TITLE: TYPE-C 16P 母座L=6.5沉板1.0 CH0.6 铜合金端子 LCP无卤				
.0	±0.35					
.00	±0.25	DRAWN/ 设计 HMY		SIZE:A4	UNIT:MM.	PART.NO: 126-222-160001-V2H
.000	±0.15	CHECKED/ 审核 LYX		SCALE: 1:1		PROJECTION
X.°	±2.00°	APPROVED/ 核准 LJP		DWG. PATH	0100-2	
ASSEMBLY DRAWING						REV.: 版本
						SHEET: 页码



REV.	DESCRIPTION	NAME	DATE

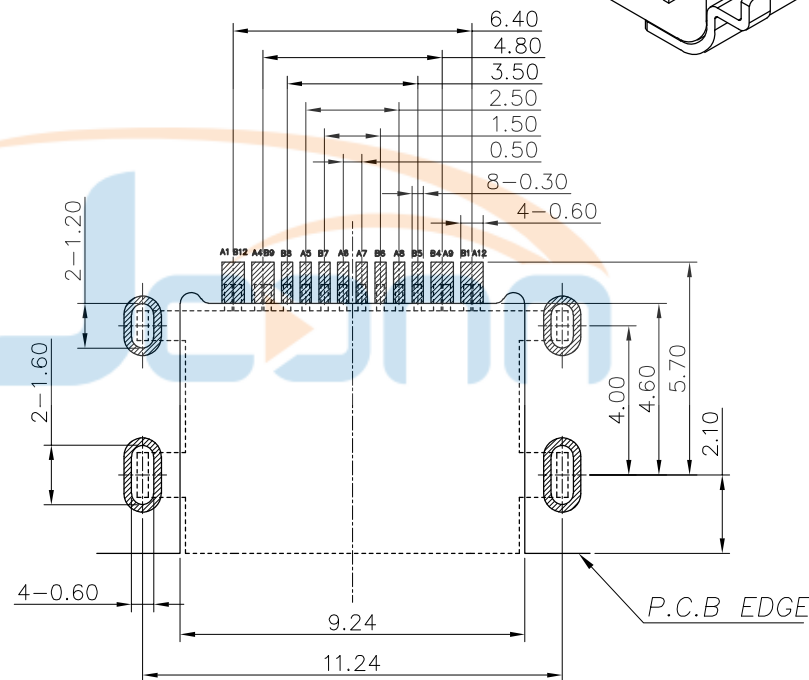
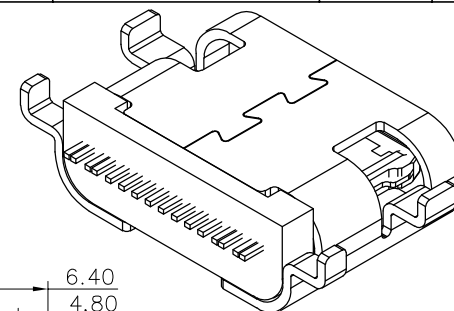
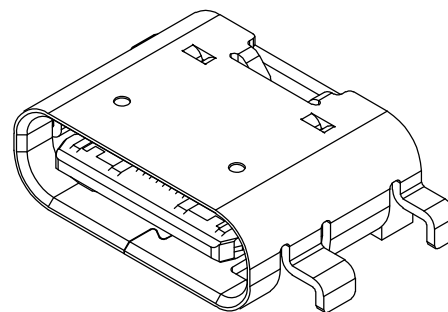

RECOMMEND P.C.B LAYOUT (COMPONENT SIDE)  
TOLERANCE FOR PCB LAYOUT IS  $\pm 0.05$

USB TYPE-C PIN ASSIGNMENTS

PIN NUMBER	SIGNAL NAME	PIN NUMBER	SIGNAL NAME
A1	GND	B12	GND
A4	VBUS	B9	VBUS
A5	CC1	B8	SBU2
A6	Dp1	B7	Dn2
A7	Dn1	B6	Dp2
A8	SBU1	B5	CC2
A9	VBUS	B4	VBUS
A12	GND	B1	GND

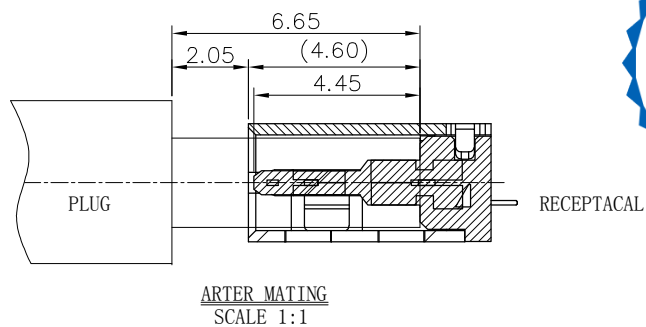

TOLERANCE UNSPECIFIED	
.0	$\pm 0.35$
.00	$\pm 0.25$
.000	$\pm 0.15$
X.°	$\pm 2.00^\circ$
ASSEMBLY DRAWING	

**深圳市步步精科技有限公司**

TITLE: TYPE-C 16P 母座L=6.5沉板1.0 CH0.6 铜合金端子 LCP无卤

DRAWN/ DATE	设计 HMY	SIZE: A4	UNIT: MM.	PART. NO: 126-222-160001-V2H
CHECKED/ DATE	审核 LYX	SCALE: 1:1	PROJECTION	REV.: 版本
APPROVED/ DATE	核准 LJP	DWG. PATH	0100-2	SHEET: 页码



出料方向  
PULL OUT DIRECTEON

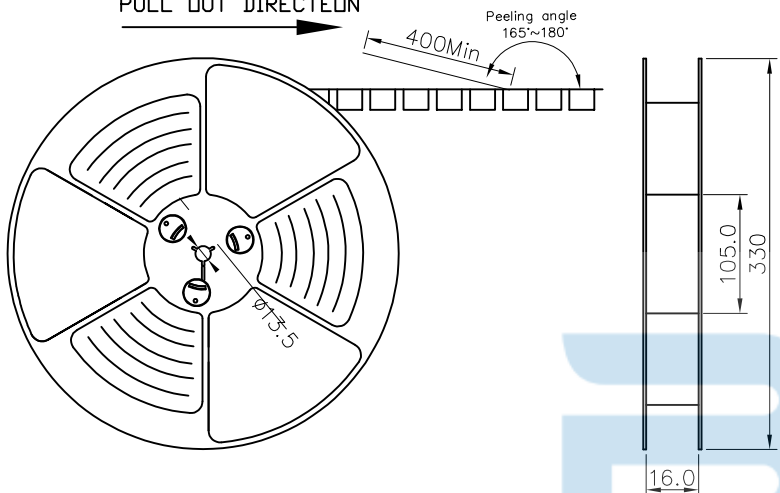

NOTES

1. 帶子引導長度  
LEAD TAPE LENGTH

出料方向  
PULL OUT DIRECTEON

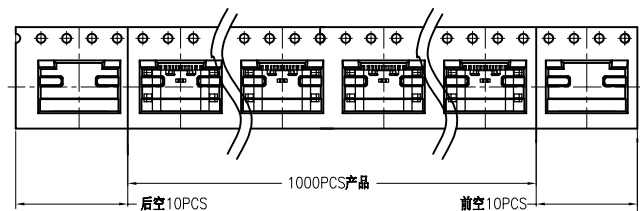

2. 上帶 剝力力為 : 0.1~1.3N(10.2gf~130gf)  
PEELING OFF FORCE OF TOP TAPE: 0.1~1.3N(10.2gf~130gf)

出貨運輸過程中一定注意:  
THIS REQUIREMENT SHOULD BE APPLIED AT SHIPMENT:  
卷帶在運輸過程中不能散開  
PEELING OFF SHOULD NOT BE ALLOWED DURING TRANSPORTATION

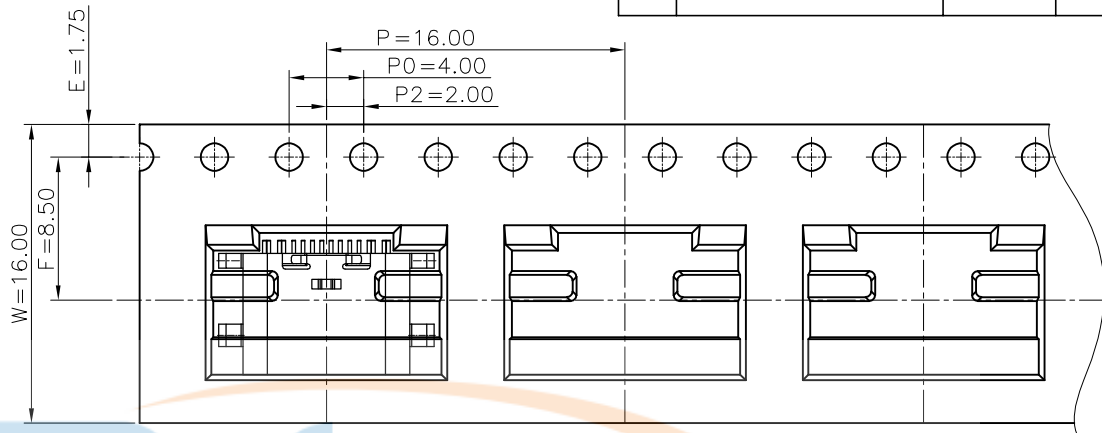

TAPE & REEL 14 PCS

1 REEL  
= 1000 PCS

BOX

DIMENSIONS:  
33.5X33.5X30.5

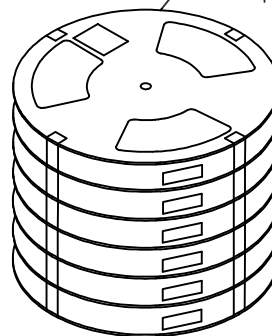

LABEL

1 CARTON  
= 14 REELS  
= 14000 PCS



TOLERANCE UNSPECIFIED

.0	±0.35
.00	±0.25
.000	±0.15
X. °	±2.00°

ASSEMBLY DRAWING

深圳市步步精科技有限公司

TITLE:  
TYPE-C 16P 母座L=6.5沉板1.0 CH0.6 铜合金端子 LCP无卤

包裝明細表 (The detail of the packing) Carton						
產品料號 (Product No.)	包裝容量 (Packing Capacity)			重量 Weight (Kg)		
	pcs/box	boxes/Carton	Pcs/Box	N.W./Pcs	N.W./Box	G.W./Box
	1000	14	14000	----	----	----

DRAWN/ DATE	设计 HMY	SIZE:A4	UNIT:MM.	PART. NO: 126-222-160001-V2H
CHECKED/ DATE	审核 LYX	SCALE: 1:1	PROJECTION	REV.: 版本
APPROVED/ DATE	核准 LJP	DWG. PATH	0100-2	SHEET: 页码

1

2

3

4

5

6

7

8