

REV	ECN NO	CONTENT	DATE	ENGINEER
A0		INITIAL RELEASE	/	GZY

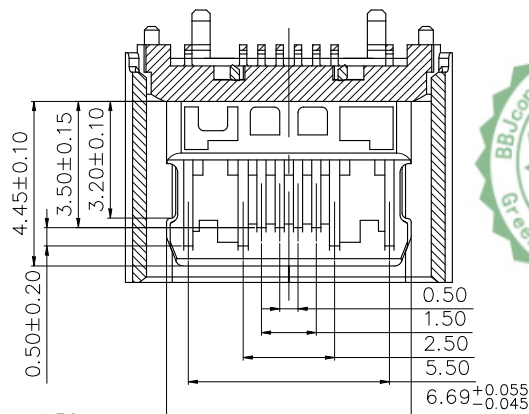

NOTE:

- MATERIAL SPECIFICATION:
 - HOUSING: HIGH TEMPERATURE RESISTANT PLASTIC, UL94 V-0.
 - CONTACTS: COPPER ALLOY
 - MID PLATE: STAINLESS STEEL
 - SHELL: STAINLESS STEEL
- PLATING SPECIFICATION:
 - CONTACTS:
 - Ni 50u" MIN. UNDER PLATED OVER ALL.
 - Au PLATED ON THE FUNCTIONAL AREA OF CONTACT.
 - GOLD FLASH PLATING ON SOLDER AREA
 - SHELL:
 - Ni 30u" MIN. UNDER PLATED OVER ALL.
- MECHANICAL PERFORMANCE,
 - INSERTION FORCE: 0.5~2.0kgf.
 - REMOVAL FORCE: 0.8kgf~2.0kgf.
 - DURABILITY: 10000 CYCLES.
- ELECTRICAL PERFORMANCE,
 - CURRENT RATING: 5A
VOLTAGE RATING: 20V
 - INSULATION RESISTANCE: 100M Ω MIN
 - DIELECTRIC WITHSTAND VOLTAGE, AC 100V FOR 1 MINUTE.
 - LOW CONTACT RESISTANCE: INITIAL 40m Ω , AFTER 50m Ω .
- ENVIRONMENTAL PERFORMANCE:
 - OPERATING TEMPERATURE: -30 $^{\circ}$ C~+80 $^{\circ}$ C.
 - THE PEAK TEMPERATURE ON THE BOARD SHALL BE MAINTAINED FOR 10 SECONDS AT 260 $^{\circ}$ C.
- IR REFLOW:

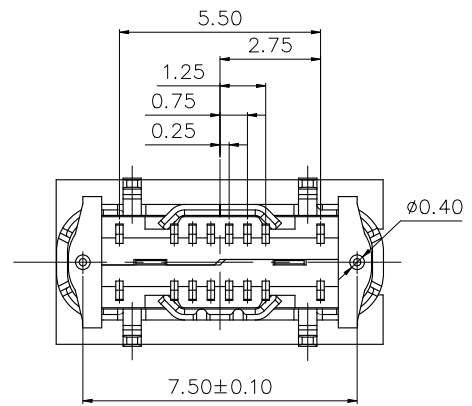
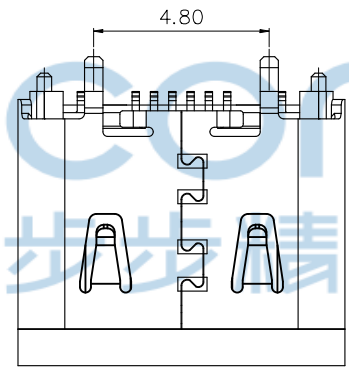
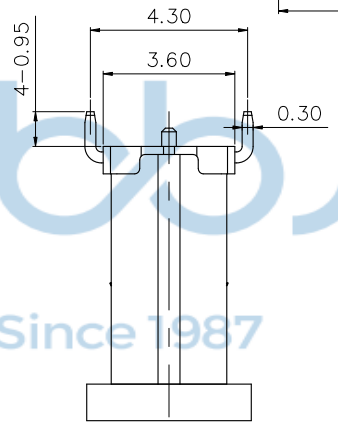
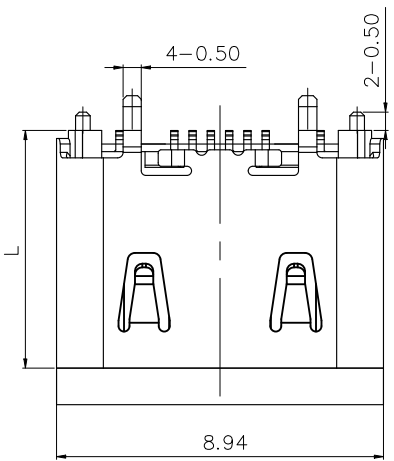

产品高度	5.5H	6.5H	6.8H	7.4H
L (mm)	5.5	6.5	6.8	7.4

5	CAP	LCP UL94V-0	BLACK	1PCS
4	OUTER SHELL	SUS304 T=0.30MM	NI 30u"MIN	1PCS
3	SHIELDING PLATE	SUS301 T=0.15MM	N/A	1PCS
2	CONTACT	C2680 T=0.15MM	Mating area 3u"Au Solder Tails: G/F Underplate: 50u"Min Ni overall	2SET
1	INSERT MOLDING	LCP UL94V-0	BLACK	1PCS
NO.	DESCRIPTION	MATERIAL	REMARKS	

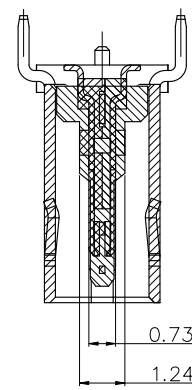
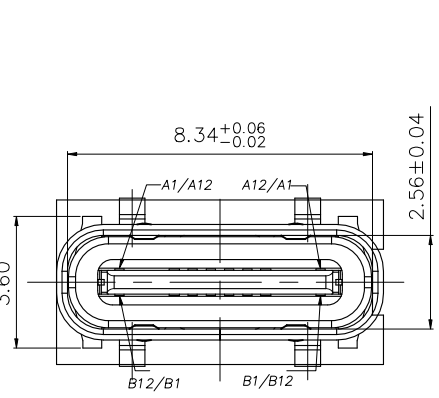

THIS DOCUMENT IS THE SOLE PROPERTY OF BBJconn Technology Co., Ltd. CORPORATION AND SHOULD NOT BE USED IN WHOLE PRIOR WRITTEN PERMISSION.

PDWG NO: 0100-2

APPD: JM_Zheng
CHKD: LYX
DR: GZY

NAME: TYPE-C 16P 母座 直立式 四脚插 端子SMT 带柱 带弹 H=6.50 小脚 (脚长0.95) 镀金3u" 编带

PJ NO: 126-224-160010-V2G
SIZE: A4
FINISH: SEE NOTES
SCALE: N/A

REMARKS: 深圳市步步精科技有限公司

REV: A0
UNIT: mm
PAGE: 1/3

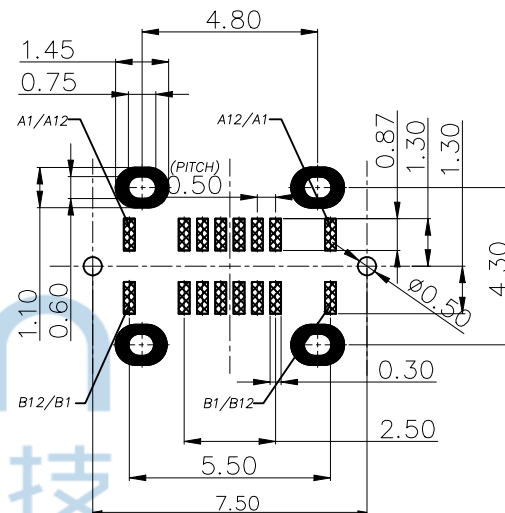
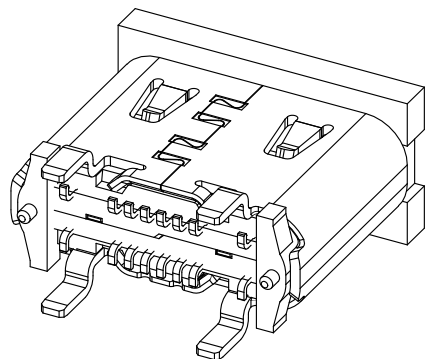

RECOMMENDED P.C.B. LAYOUT
TOLERANCE UNSPECIFIED $\pm 0.05\text{mm}$

USB TYPE-C PIN ASSIGNMENTS

PIN NUMBER	SIGNAL NAME	PIN NUMBER	SIGNAL NAME
A1	GND	B12	GND
A4	VBUS	B9	VBUS
A5	CC1	B8	SBU2
A6	Dp1	B7	Dn2
A7	Dn1	B6	Dp2
A8	SBU1	B5	CC2
A9	VBUS	B4	VBUS
A12	GND	B1	GND



THIS DOCUMENT IS THE SOLE PROPERTY OF		深圳市步步精科技有限公司	
BBJconn Technology Co.,Ltd. Corporation AND SHOULD NOT BE USED IN WHOLE PRIOR WRITTEN PERMISSION.		.X: ± 0.38 .XX: ± 0.25 .XXX: ± 0.13 X': $\pm 3^{\circ}$.X': $\pm 2^{\circ}$.XX': $\pm 1^{\circ}$	NAME: TYPE-C 16P 母座 直立式 四脚插 端子SMT 带柱 带弹 H=6.50 小脚 (脚长0.95) 镀金3u" 编带
APPD	JM_Zheng	PJ NO: 126-224-160010-V2G SIZE: A4 DRW NO:	
CHKD	LYX		
PDWG NO: 0100-2	DR GZY	FINISH: SEE NOTES MAT'L: SEE NOTES SCALE: N/A REV: A0 UNIT: mm PAGE: 2/3	

REV	ECN NO	CONTENT	DATE	ENGINEER
A0		INITIAL RELEASE	/	GZY

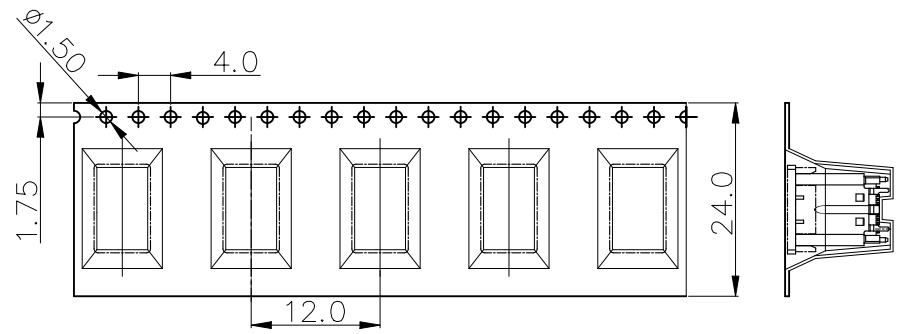
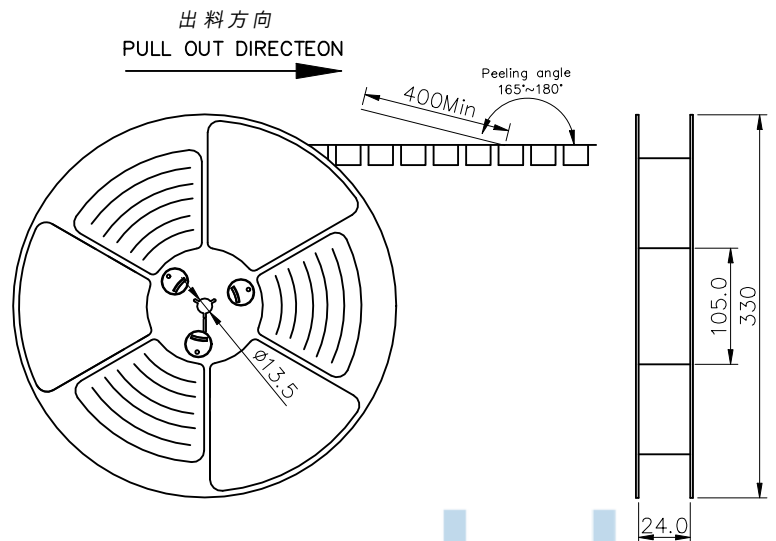

NOTES

1. 帶子引導長度
LEAD TAPE LENGTH
出料方向
PULL OUT DIRECTEON

出料方向
PULL OUT DIRECTEON

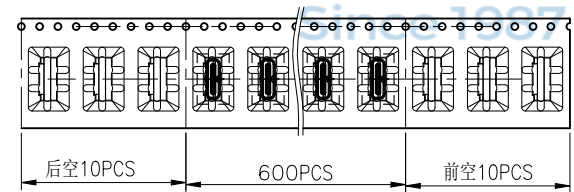

2. 上帶 剝力力為 : 0.1~1.3N(10.2gf~130gf)
PEELING OFF FORCE OF TOP TAPE: 0.1~1.3N(10.2gf~130gf)
出貨 運輸過程中一定注意:
THIS REQUIREMENT SHOULD BE APPLIED AT SHIPMENT:
卷帶在運輸過程中不能散開
PEELING OFF SHOULD NOT BE ALLOWED DURING TRANSPORTATION

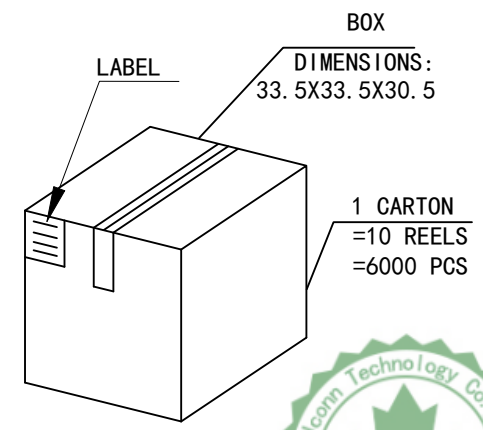
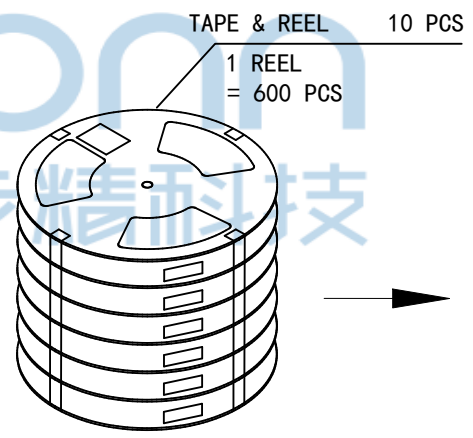

(The detail of the packing)

包裝容量 (Packing Capacity)			重量 Weight (Kg)		
pcs/box	boxs/Carton	Pcs/Box	N.W./Pcs	N.W./Box	G.W./Box
600	10	6000	---	---	---

THIS DOCUMENT IS THE SOLE PROPERTY OF BBJconn Technology Co.,Ltd. Corporation AND SHOULD NOT BE USED IN WHOLE PRIOR WRITTEN PERMISSION.		深圳市步步精科技有限公司 .X: ±0.38 X': ±3' .XX: ±0.25 .X': ±2' .XXX: ±0.13 .XX': ±1'		NAME: TYPE-C 16P 母座 直立式 四脚插 端子SMT 带柱 带弹 H=6.50 小脚(脚长0.95) 镀金3u" 编带	
APPD	JM_Zheng	PJ NO: 126-224-160010-V2G SIZE: A4 DRW NO:	FINISH: SEE NOTES MAT'L: SEE NOTES		
CHKD	LYX		SCALE: N/A REV: A0 UNIT: mm PAGE: 3/3		
PDWG NO: 0100-2	DR	GZY			