

REV.	ECN NO	CONTENT	DATE	ENGINEER
A0		Initial release	/	TSP

NOTE:

- MECHANICAL:
 - 1-1. MATING FORCE: 0.5~2.0Kgf
 - 1-2. UMMATING FORCE: Initial: 0.8~2.0Kgf
After 500 to 10,000cycles: 0.6~2.0Kgf
 - 1-3. FREQUENCE: 500±50 CYCLES/HOUR, 10000 CYCLES;
- ELECTRICAL CHARACTERISTICS:
 - 2-1. CURRENT RATING: 1.25A/PIN FOR FOR VBUS AND GND
0.25 A FOR OTHER PINS
 - 2-2. INITIAL CONTACT RESISTANCE: 40mΩ Max.
 - 2-3. INSULATION RESISTANCE: 100MΩ MIN
 - 2-4. WITHSTANDING VOLTAGE: 100V AC, 1 MINUTE;
- ENVIRONMENTAL
TEMPERATRU E RANGE: -40° C TO +85° C.

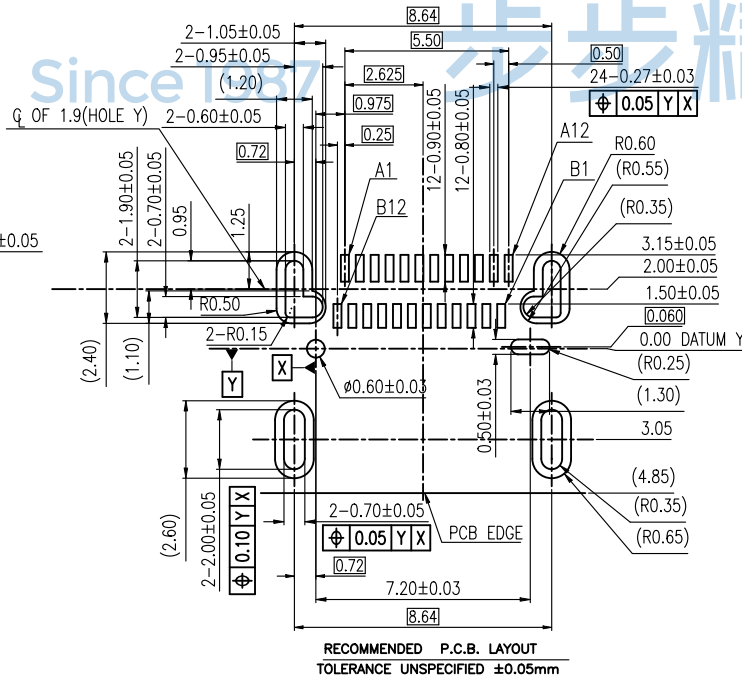
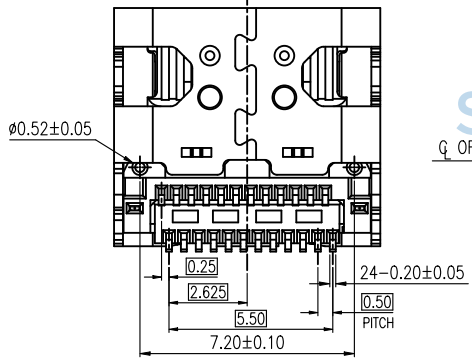
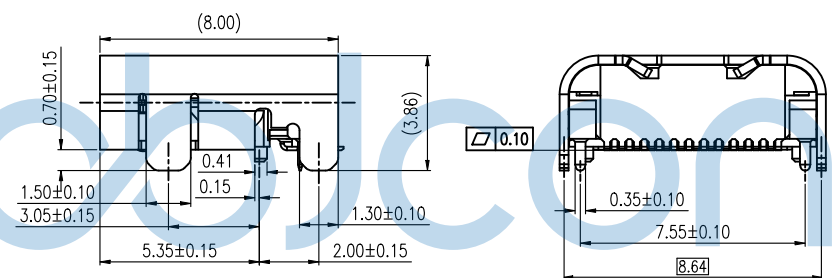
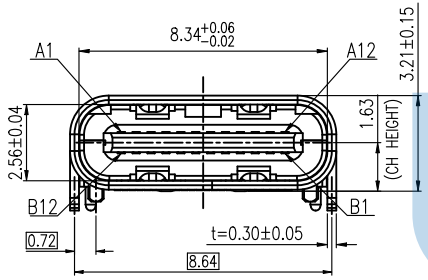
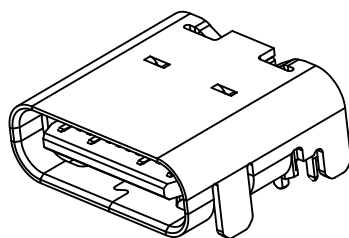
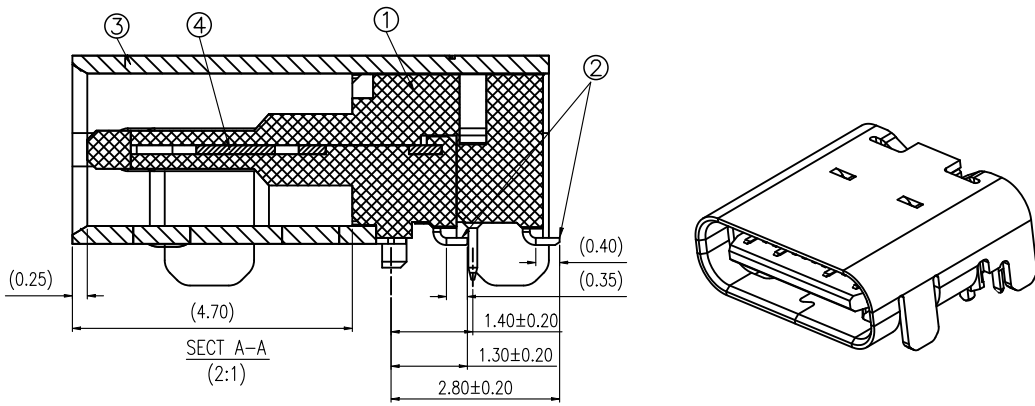

A1	GND	B12	GND
A2	SSTXP1	B11	SSRXP1
A3	SSTXN1	B10	SSRXN1
A4	VBUS	B9	VBUS
A5	CC1	B8	SBU2
A6	DP1	B7	DN2
A7	DN1	B6	DP2
A8	SBU1	B5	CC2
A9	VBUS	B4	VBUS
A10	SSRXN2	B3	SSTXN2
A11	SSRXP2	B2	SSTXP2
A12	GND	B1	GND
PIN	SIGNAL NAME	PIN	SIGNAL NAME

ITEM	PART NAME	Q'TY	MATERIAL	FINISH
	Insulator	1	THERMOPLASTIC LCP	Black, UL94V-0
2	CONTACT	1	HIGH CONDUCTIVITY COPPER C7025	Contact area: Au 3U" Min OVER Ni 40U" Min; SOLDER TAILS: Au 1U" Min OVER Ni 40U" Min.
3	SHELL	1	STAINLESS STEEL SUS304	30u" Ni plated over all
	MID-PLATE	1	STAINLESS STEEL SUS301	30u" Ni plated over all

THIS DOCUMENT IS THE SOLE PROPERTY OF BBJconn Technology Co., Ltd. Corporation AND SHOULD NOT BE USED IN WHOLE OR IN PART WITHOUT PRIOR WRITTEN PERMISSION.

PDWG. NO: 0382-1

APPD. JM_Zheng

CHKD. LYX

DR. TSP

深圳市步步精科技有限公司

NAME: TYPE-C 24P 母座 板上四脚插 带柱 L=8.0 CH=1.63 端子双排SMT 不带EMI 无LOGO

PJ. NO.: UC.01.52-1G-0004

SIZE: A4 DRW NO.:

FINISH: SEE NOTES MAT'L.: SEE NOTES

SCALE: N/A REV.: A0 UNIT: mm PAGE: 1/2

REV.	ECN NO	CONTENT	DATE	ENGINEER
AO		Initial release	/	TSP

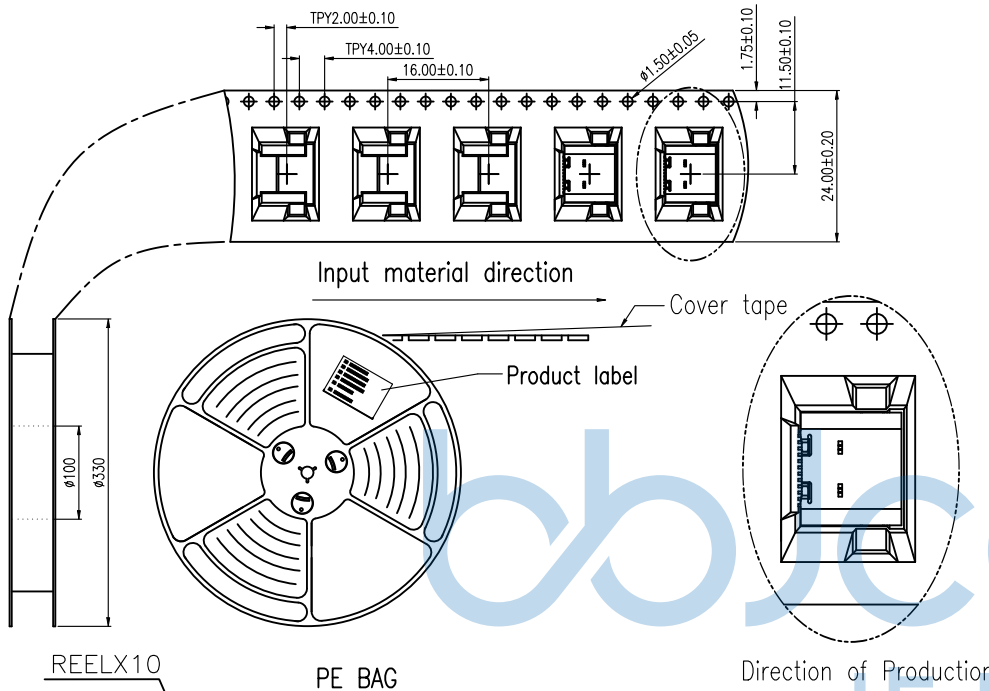

NOTES

1. NUMBER OF CONNECTORS: 1050PCS/REEL
2. LEAD TAPE LENGTH

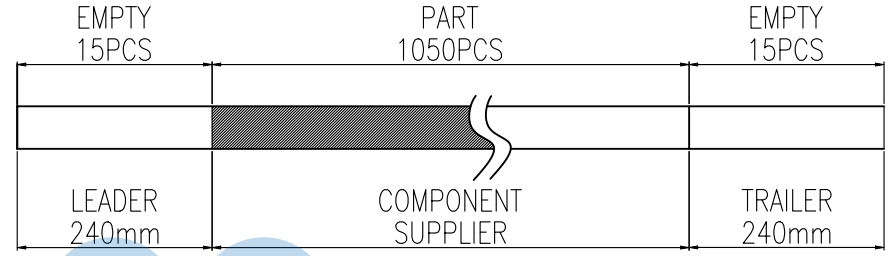

3. QUANTITY: 10500/CARTON
4. WEIGHT :
 - 4.1 NET WEIGHT : 5.43 Kg
 - 4.2 GROSS WEIGHT : 10.6 Kg

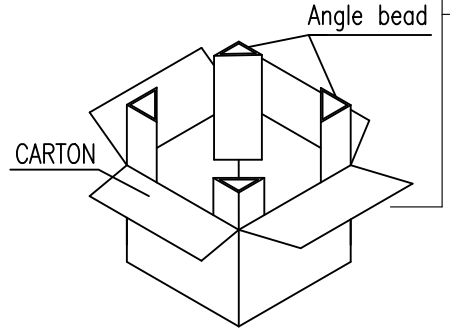
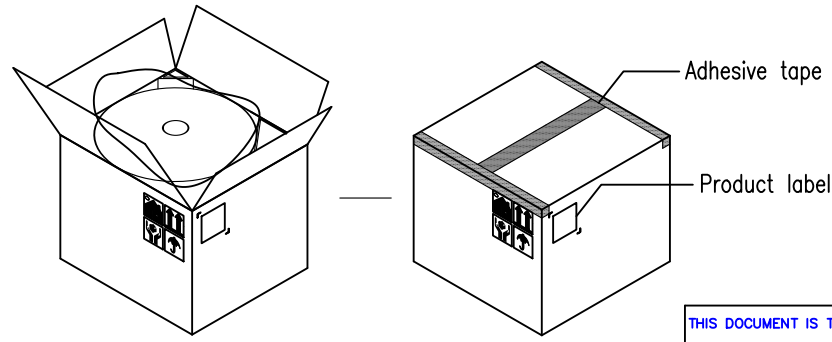
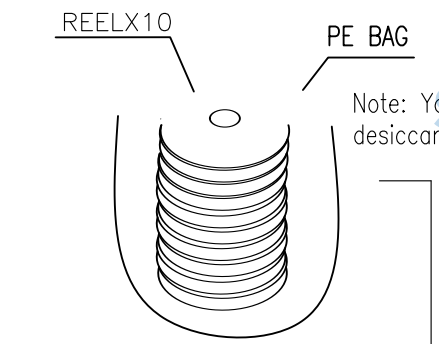

THIS DOCUMENT IS THE SOLE PROPERTY OF BBJconn Technology Co.,Ltd. Corporation AND SHOULD NOT BE USED IN WHOLE OR IN PART WITHOUT PRIOR WRITTEN PERMISSION.		深圳市步步精科技有限公司 工程 部	
.X: ±0.38 .X': ±3" .XX: ±0.25 .X'': ±2" .XXX: ±0.13 .X''': ±1"		NAME: TYPE-C 24P 母座 板上四脚插 带柱 L=8.0 CH=1.63 端子双排SMT 不带EMI 无LOGO	
APPD.	JM_Zheng	PJ. NO.: UC.01.52-1G-0004	
CHKD.	LYX	SIZE: A4 DRW NO.:	
DR.	TSP	FINISH: SEE NOTES MAT'L.: SEE NOTES	
PDWG.NO:	0382-1	SCALE: N/A	REV.: AO UNIT: mm PAGE: 2/2