

REV.	ECN NO	CONTENT	DATE	ENGINEER
AO		Initial release	/	TSP

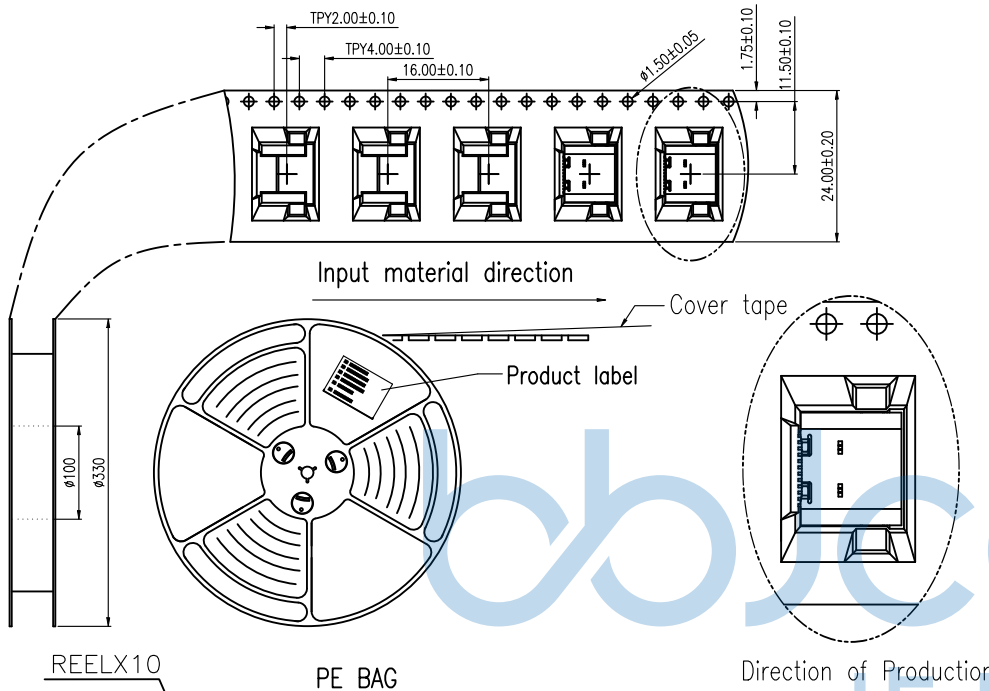

NOTES

1. NUMBER OF CONNECTORS: 1050PCS/REEL
2. LEAD TAPE LENGTH

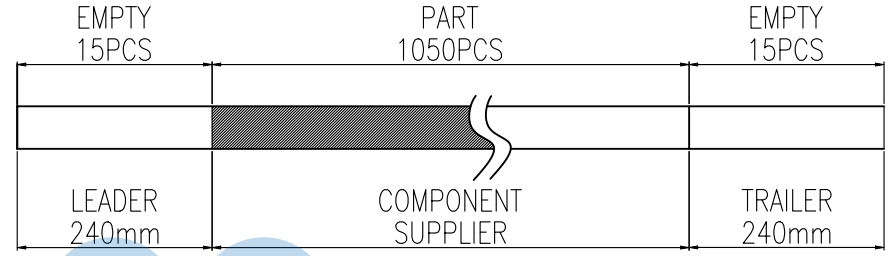

3. QUANTITY: 10500/CARTON
4. WEIGHT :
 - 4.1 NET WEIGHT : 5.43 Kg
 - 4.2 GROSS WEIGHT : 10.6 Kg

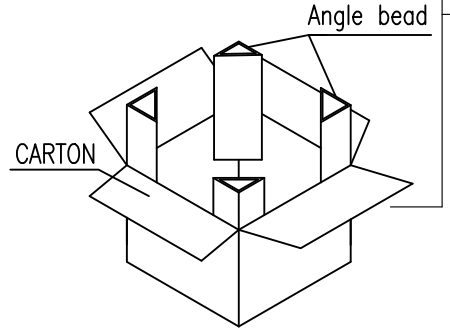
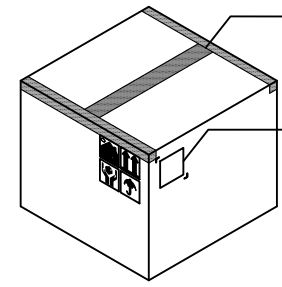
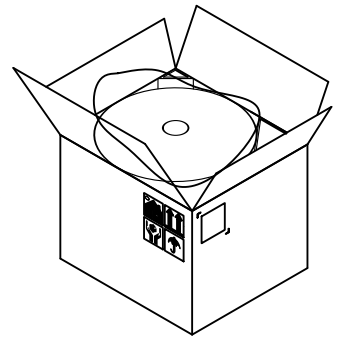
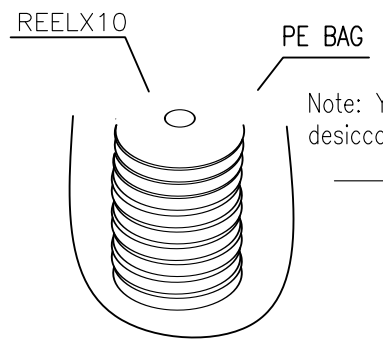

THIS DOCUMENT IS THE SOLE PROPERTY OF BBJconn Technology Co., Ltd. Corporation AND SHOULD NOT BE USED IN WHOLE OR IN PART WITHOUT PRIOR WRITTEN PERMISSION.		深圳市步步精科技有限公司 工程 部	
.X: ±0.38 .XX: ±0.25 .XXX: ±0.13		X*: ±3* .X*: ±2* .XX*: ±1*	
APPD.	JM_Zheng	NAME: TYPE-C 24P 母座 板上四脚插 带柱 L=8.0 CH=1.63 端子双排SMT 不带EMI 无LOGO 蓝胶 编带	
CHKD.	LYX	PJ. NO.: 126-221-240020-J8G	
DR.	TSP	SIZE: A4 DRW NO.:	
PDWG.NO:	0382-1	FINISH: SEE NOTES MAT'L.: SEE NOTES	
		SCALE: N/A	REV.: AO UNIT: mm PAGE: 2/2