

REV	ECN NO	CONTENT	DATE	ENGINEER
A0		INITIAL RELEASE	/	SGF

NOTES:

- MATERIAL:
MOLDING: LCP UL94 V-0
CONTACT: COPPER ALLOY.
GOLD PLATING ALL OVER 50u" Min NICKEL
AND 100u" Min Tin ALL OVER 50u" Min NICKEL
ON SOLDER AREA
SHELL: SUS304-H,T=0.30±0.03mm
50u" NICKEL PLATING OVER ALL.
- MECHANICAL:
INSERTION: 5~20N.
EXTRACTION: 8~20N AFTER TEST .
DURABILITY: 10000 CYCLES
- ELECTRICAL:
CURRENT: 5A FOR VBUS;
1.25A FOR GND PIN.
0.25A FOR OTHER.
VOLTAGE: 20 V MAX
WITHSTANDING VOLTAGE: 100V AC R.M.S
CONTACT RESISTANCE: 40mΩ MAX.
INSULATION RESISTANCE: 100MΩ MIN.
- ENVIRONMENTAL
TEMPERATURE RANGE -55°C ~ +85°C

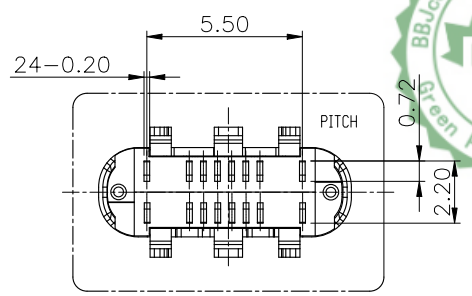
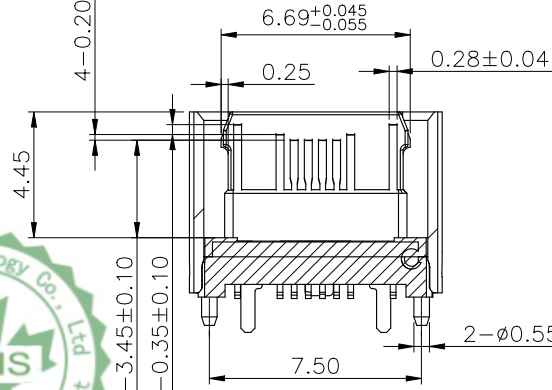
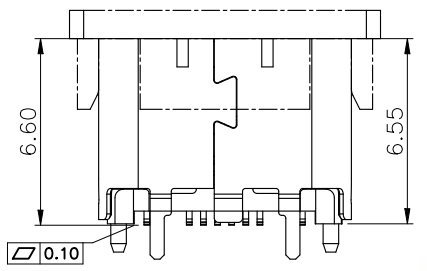
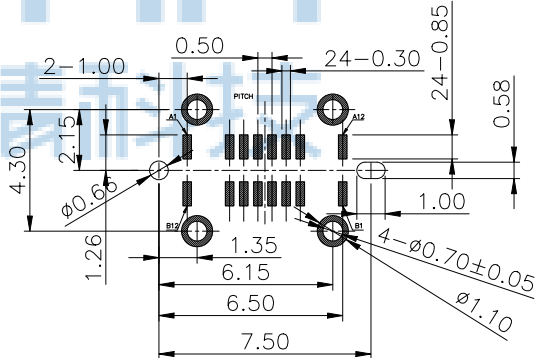
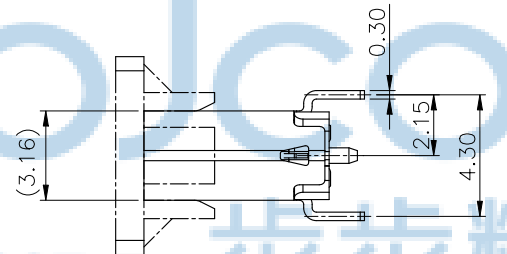
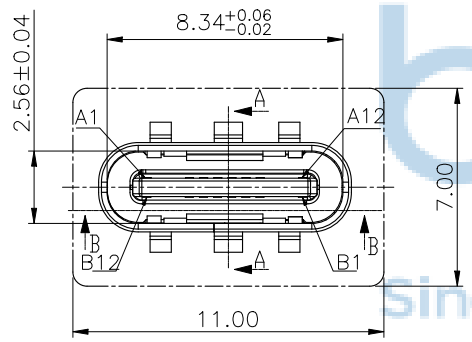
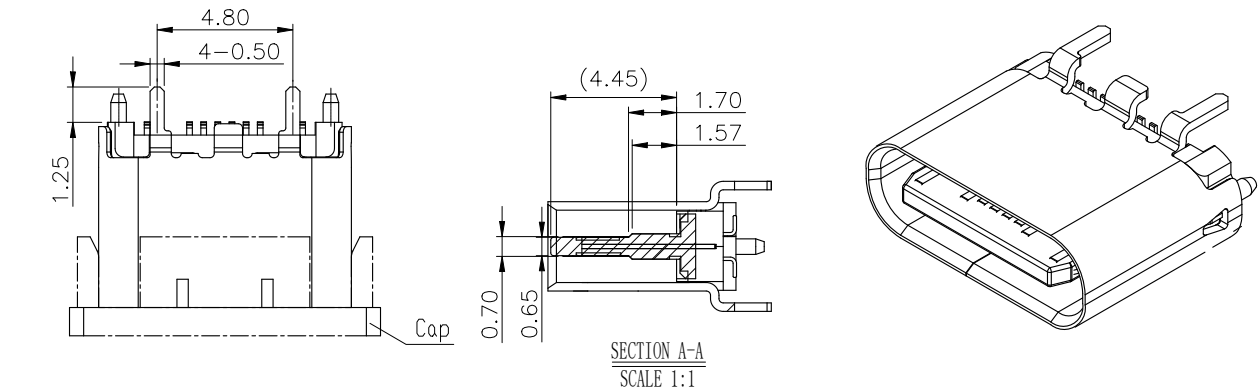

PIN	Signal Name	PIN	Signal Name
A1	GND	B12	GND
A4	VBUS	B9	VBUS
A5	CC1	B8	SBU2
A6	Dp1	B7	Dn2
A7	Dn1	B6	Dp2
A8	SBU1	B5	CC2
A9	VBUS	B4	VBUS
A12	GND	B1	GND

THIS DOCUMENT IS THE
SOLE PROPERTY OF
BBJconn Technology Co.,Ltd.
Corporation AND SHOULD
NOT BE USED IN WHOLE
PRIOR WRITTEN PERMISSION.
PDWG NO: 0285-1

深圳市步步精科技有限公司

NAME: TYPE-C 16P 母座 直立式 六脚插 带定位柱
端子SMT H=6.55 编带

APPD	JM_Zheng		PJ NO: 126-224-160006-J8G	
CHKD	LYX		SIZE:A4	DRW NO:
DR	SGF	FINISH:SEE NOTES	MAT'L:SEE NOTES	
		SCALE:N/A	REV:A0	UNIT:mm PAGE:1/3

REV	ECN NO	CONTENT	DATE	ENGINEER
A0		INITIAL RELEASE	/	SGF

出料方向
PULL OUT DIRECTEON

NOTES

- 帶子引導長度
LEAD TAPE LENGTH
出料方向
PULL OUT DIRECTEON

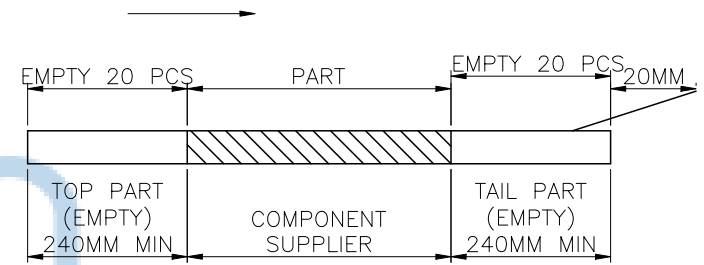
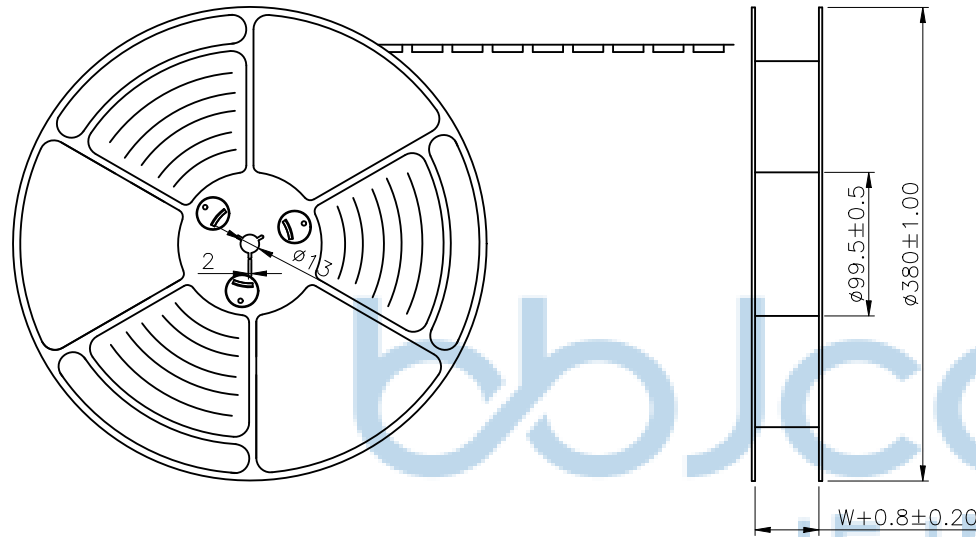

Since 1987

步步精科技

- 出貨'運輸過程中一定要注意:
THIS REQUIREMENT SHOULD BE APPLIED AT SHIPMENT:
卷帶在運輸過程中不能散開
PEELING OFF SHOULD NOT BE ALLOWED DURING TRANSPORTATION

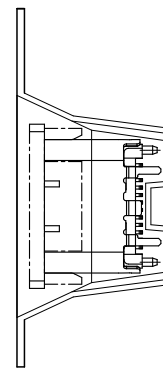
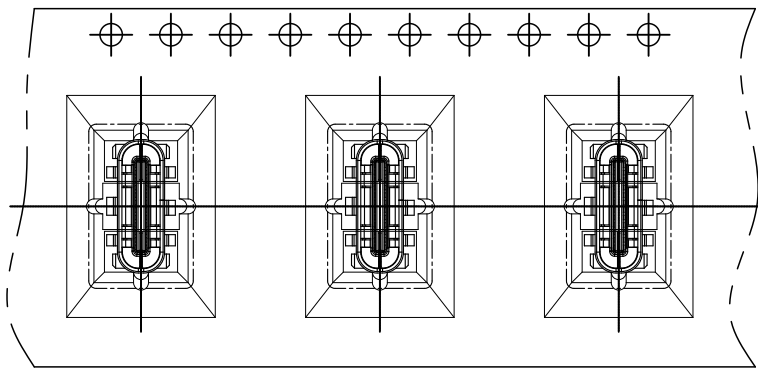

THIS DOCUMENT IS THE SOLE PROPERTY OF BBJconn Technology Co.,Ltd. Corporation AND SHOULD NOT BE USED IN WHOLE PRIOR WRITTEN PERMISSION.	深圳市步步精科技有限公司		NAME: TYPE-C 16P 母座 直立式 六脚插 带定位柱 端子SMT H=6.55 编带	
	APPD	JM_Zheng	PJ NO: 126-224-160006-J8G SIZE:A4 DRW NO:	FINISH:SEE NOTES MAT'L:SEE NOTES SCALE:N/A REV:A0 UNIT:mm PAGE:2/3
	CHKD	LYX		
	PDWG NO: 0285-1	DR	SGF	

at small positioning hole of the carrier tape side).
標籤黏貼處 (朝捲裝包材的小定位孔一側)

Location of label sticking (label

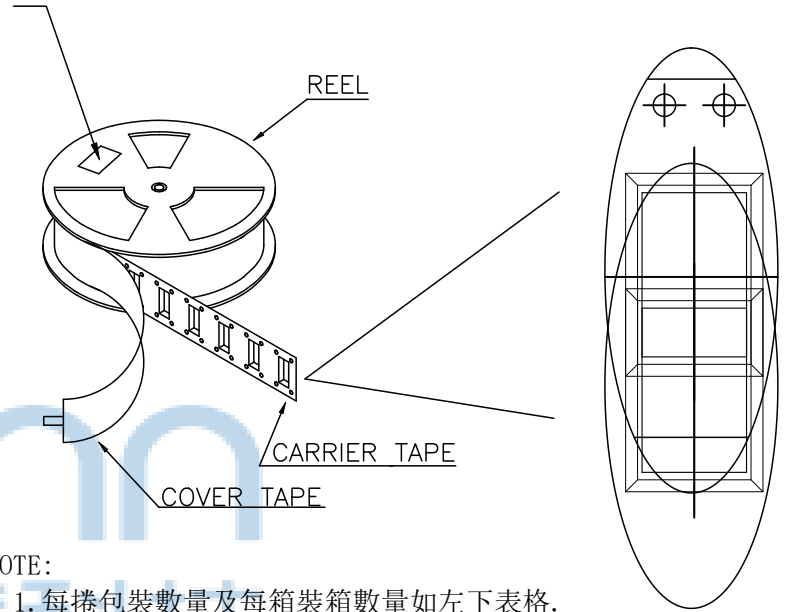

NOTE:

1. 每捲包裝數量及每箱裝箱數量如左下表格。
Packing q'ty of each reel & carton as below table shown.
2. 以上膠帶覆蓋下包裝帶經包裝機熱熔包裝
Use cover tape to cover and hot melt machine to seal up.
3. 每個紙箱放2個珍珠棉
Every carton use 2pcs EPE.
4. 將裝滿產品的卷盤放入紙箱并以膠帶封口
Put reels in the carton and use adhesive tape to seal up.

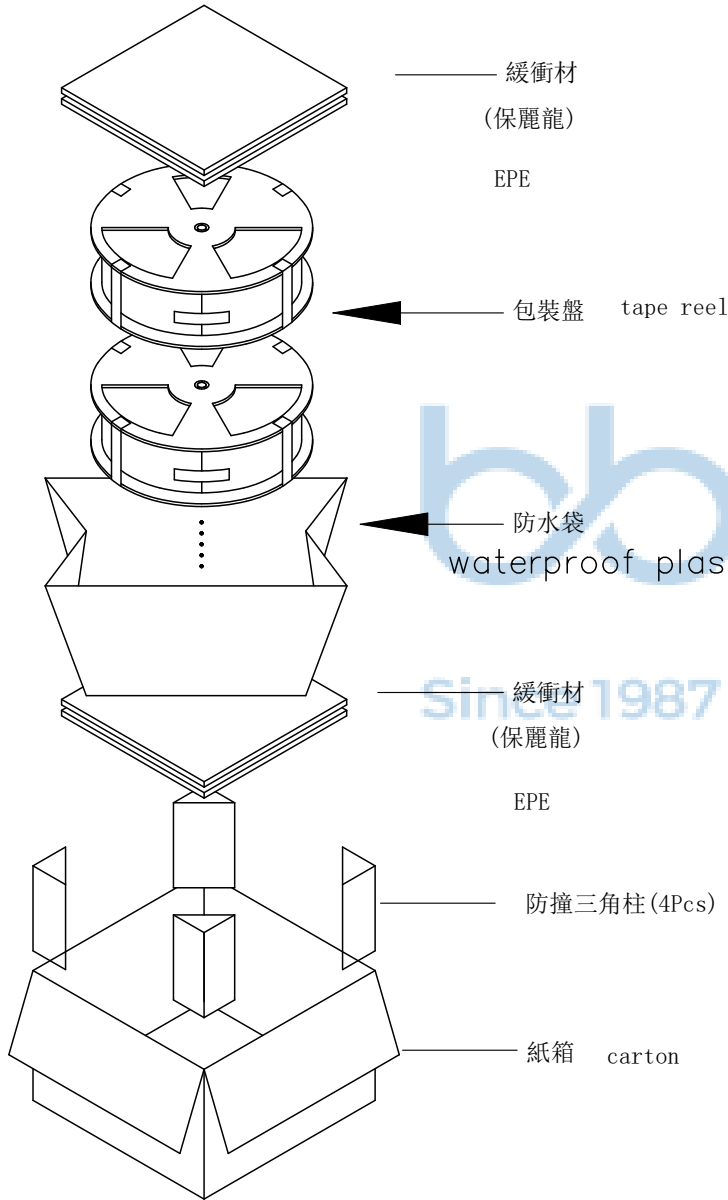

產品料號 (PRODUCT No.)	包裝容量 (PACKING CAPACITY)			重量 WEIGHT (Kg)		
	PCS/REEL	REELS/CARTON	PCS/CARTON	N.W./PCS	N.W./BOX	G.W./BOX
	800	8	6400			

THIS DOCUMENT IS THE SOLE PROPERTY OF BBJconn Technology Co.,Ltd. Corporation AND SHOULD NOT BE USED IN WHOLE PRIOR WRITTEN PERMISSION.		深圳市步步精科技有限公司 工程 部		NAME: TYPE-C 16P 母座 直立式 六脚插 帶定位柱 端子SMT H=6.55 編帶 PJ NO: 126-224-160006-J8G SIZE:A4 DRW NO:	
APPD	JM_Zheng			FINISH:SEE NOTES MAT'L:SEE NOTES	
CHKD	LYX	SCALE:N/A		REV:AO	UNIT:mm PAGE:3/3
PDWG NO: 0285-1		DR	SGF		